

BOX DOCCIA

BOX DOCCIA
SHOWER BOX
DUSCHKABINEN

B



01/2020



BOX DOCCIA

INDICE / INDEX / INHALT



I NUOVI CATALOGHI METALGLAS BONOMI E I NUOVI LISTINI	2
<i>THE NEW CATALOGS METALGLAS BONOMI AND NEW PRICE LISTS</i>	
<i>DIE NEUEN KATALOGE METALGLAS BONOMI UND NEUE PREISLISTEN</i>	
DAL CATALOGO AL LISTINO CON UN SEMPLICE CODICE	4
<i>FROM THE CATALOG TO THE LIST WITH A SIMPLE CODE</i>	
<i>VOM KATALOG ZUR LISTE MIT EINEM EINFACHEN CODE</i>	
LEGENDA SIMBOLI	6
<i>SYMBOL LEGEND</i>	
<i>SYMBOLLEGENDE</i>	
LEGENDA ABBREVIAZIONI	7
<i>ACRONYM LEGEND</i>	
<i>ERKLÄRUNG DER ABKÜRZUNGEN</i>	
FINITURE	7
<i>FINISHES</i>	
<i>OBERFLÄCHEN</i>	
<hr/>	
B BOX DOCCIA	8
<i>SHOWER BOX</i>	
<i>DUSCHKABINEN</i>	
GUIDA TECNICA PER LA SCELTA DEL VOSTRO SISTEMA	10
<i>TECHNICAL GUIDE FOR THE CHOICE OF YOUR SYSTEM</i>	
<i>AUSWAHL VON SCHIEBETÜRSYSTEMEN NACH VORHANDENEN KRITERIEN</i>	

I NUOVI CATALOGHI METALGLAS BONOMI

THE NEW CATALOGS METALGLAS BONOMI
DIE NEUEN KATALOGE METALGLAS BONOMI



SCORREVOLI

A | SISTEMI SCORREVOLI
SLIDING DOOR SYSTEMS
SCHIEBETÜRSYSTEME



BOX DOCCIA

B | BOX DOCCIA
SHOWER BOX
DUSCHKABINEN



OUTDOOR PARETI MOBILI

C | PARETI MOBILI
SLIDING WALLS
SCHIEBEWÄNDE

... E I NUOVI LISTINI PREZZI

... AND NEW PRICE LISTS
... UND NEUE PREISLISTEN

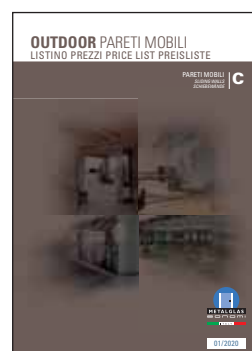
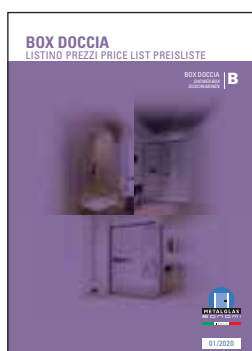



INDOOR

- D** PARETI DIVISORIE E STIPITI
PARTITION WALLS AND FRAMES
TRENNWÄNDE UND ALUMINIUMZARGEN
- E** SERRATURE E CERNIERE
LOCKS AND HINGES
SCHLÖSSER UND BÄNDER
- F** MANIGLIE MANIGLIONI POMOLI
DOORHANDLES PULLHANDLES KNOBS
TÜRGRIFFE STOSSGRIFFE KNÖPFE
- G** PORTE ESTERNE
PATCH FITTINGS
GANZGLASANLAGEN

OUTDOOR BALAUSTR E PENSILINE

- H** BALAUSTR E PENSILINE
RAILING AND CANOPY SYSTEMS
GANZGLASGÄLÄNDER UND VORDACHSYSTEME
- I** DISTANZIALI MORSETTI ACCESSORI
POINT FITTINGS CLAMPS ACCESSORIES
PUNKTHALTERUNG KLEMMBEFESTIGUNGEN ZUBEHÖRE

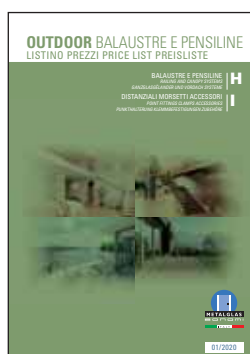
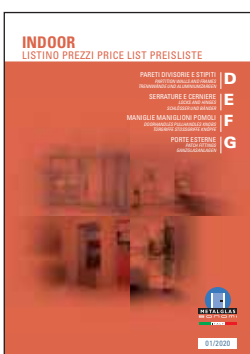

DAL CATALOGO AL LISTINO CON UN SEMPLICE CODICE

FROM THE CATALOG TO THE LIST WITH A SIMPLE CODE
VOM KATALOG ZUR LISTE MIT EINEM EINFACHEN CODE

SEARCH FOR THE CODE
OF EVERY PRODUCT IN
CATALOG...

*(ERCA IL CODICE
DI OGNI PRODOTTO NEL
CATALOGO...)*

SUCHE NACH DEM CODE
VON JEDEM PRODUKT IN
KATALOG ...



COMPONENTI / COMPONENTS / EINZELTEILE ▶ 12

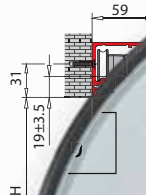
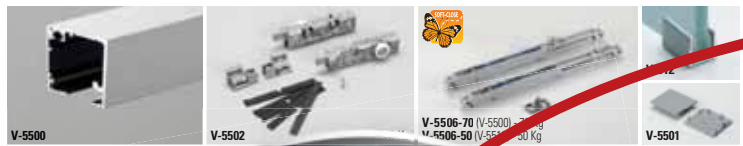

SET 1 € ▶ A.01 € ▶ A.03

V-5506-70
• Set p
• Sliding
• Schieb
V-5506-50
• Set p
• Sliding
• Schieb

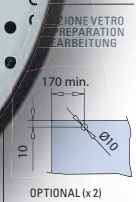
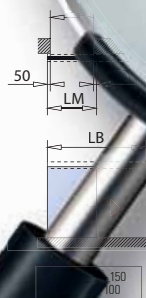

$LB = LP \times 2 + 100$
 $LM = (LP + 100) / 2$

	Fin. Fin. Oberf.	V-5500 V-5510 SET 1 FIX	V-5500 V-5510 SET 1 MIS	V-5500 V-5510 SET 2 FIX	V-5500 V-5510 SET 2 MIS
L=2000 L=3000 L=4000 L=6000	AN / IXE	1	1	1	1
MIS L=1500 → 6000	AN / IXE	1	1	1	1
		1	1	2	2
V-5506-70 (V-5500)-70 Kg V-5506-50 (V-5510)-50 Kg		1	1	2	2
V-5501	AN / IXE	1	1	1	1
V-012	AN / NS	1	1	2	2

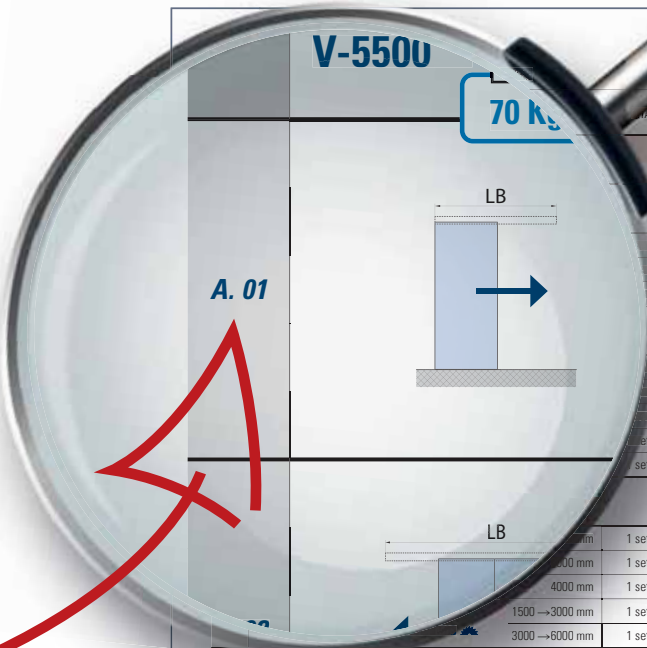

V-5500 70 Kg

A. 01

► SLIDING 14/15

FIN.	EURO	FIN.	EURO	FIN.	EURO
AN	361,00 /set	IXE	416,70 /set		
AN	422,30 /set	IXE	502,70 /set		
AN	482,30 /set	IXE	588,50 /set		
AN	473,30 /set	IXE	563,30 /set		
AN	682,30 /set	IXE	858,70 /set		
AN	628,00 /set	IXE	712,30 /set		
AN	688,50 /set	IXE	798,00 /set		
AN	816,00 /set	IXE	976,00 /set		
AN	678,30 /set	IXE	769,00 /set		
AN	881,00 /set	IXE	1054,00 /set		

► SLIDING 14/15

FIN.	EURO	FIN.	EURO	FIN.	EURO
AN	361,00 /set	IXE	416,70 /set		
AN	422,30 /set	IXE	502,70 /set		
AN	482,30 /set	IXE	588,50 /set		
AN	473,30 /set	IXE	563,30 /set		
AN	682,30 /set	IXE	858,70 /set		
AN	628,00 /set	IXE	712,30 /set		
AN	688,50 /set	IXE	798,00 /set		
AN	816,00 /set	IXE	976,00 /set		
AN	678,30 /set	IXE	769,00 /set		
AN	881,00 /set	IXE	1054,00 /set		

V-5510 SET 2 FIX

2000 mm	1 set	AN	377,30 /set	IXE	432,00 /set
3000 mm	1 set	AN	477,00 /set	IXE	526,50 /set
4000 mm	1 set	AN	516,70 /set	IXE	621,00 /set
6000 mm	1 set	AN	659,50 /set	IXE	813,30 /set

V-5510 SET 2 MIS

1500 → 3000 mm	1 set	AN	500,70 /set	IXE	589,70 /set
3000 → 6000 mm	1 set	AN	738,70 /set	IXE	935,30 /set

V-5503 70 Kg

A. 05

V-5503 SET 1 FIX

2000 mm	1 set	AN	377,30 /set	IXE	432,00 /set
3000 mm	1 set	AN	477,00 /set	IXE	526,50 /set
4000 mm	1 set	AN	516,70 /set	IXE	621,00 /set
6000 mm	1 set	AN	659,50 /set	IXE	813,30 /set

V-5503 SET 1 MIS

1500 → 3000 mm	1 set	AN	500,70 /set	IXE	589,70 /set
3000 → 6000 mm	1 set	AN	738,70 /set	IXE	935,30 /set

V-5503 SET 2 FIX

3000 mm	1 set	AN	653,50 /set	IXE	712,30 /set
4000 mm	1 set	AN	723,30 /set	IXE	798,00 /set
6000 mm	1 set	AN	866,00 /set	IXE	976,00 /set

V-5503 SET 2 MIS

1500 → 3000 mm	1 set	AN	706,00 /set	IXE	769,00 /set
3000 → 6000 mm	1 set	AN	935,30 /set	IXE	1054,00 /set

6

FIX

- Confezioni industriali
- Industrial packaging
- Industrieverpackungen

MIS

- Tagliato a misura del cliente
- Custom length
- Nach Mass geschnitten

SLIDING 14/15

- Tagliato dal cliente
- Cut by installer
- Schmitt bausteitig

70 Kg

- Trasporto fuori strada
- Non-standard transport
- Sondertransport

POS.	PROD.	ART.	MIS.
	V-5513 70 Kg 50 Kg		
A. 07	V-5513 SET 1 FIX		2000 mm 3000 mm 4000 mm 6000 mm
	V-5513 SET 1 MIS		1500 → 3000 mm 3000 → 6000 mm
A. 08	V-5513 SET 2 FIX		3000 mm 4000 mm 6000 mm
	V-5513 SET 2 MIS		1500 → 3000 mm 3000 → 6000 mm
V-5500 / V-5510 / V-5503 / V-5513 COMPONENTI / COMPONENTS / EINZELTEILE			
A. 09	V-5500		2000 mm 3000 mm 4000 mm 6000 mm
	V-5500 MIS		1500 → 3000 mm 3000 → 6000 mm
A. 10	V-5503		2000 mm 3000 mm 4000 mm 6000 mm
	V-5503 MIS		1500 → 3000 mm 3000 → 6000 mm
A. 11	V-5502		
A. 12	V-5506-70		

... **RITROVERAI VELOCEMENTE
LO STESSO CODICE NEL
LISTINO**

YOU'LL FIND QUICKLY
THE SAME CODE
IN THE PRICE LIST

... SIE FINDEN SCHNELL
DEN GLEICHEN CODE
IN DER PREISLISTE

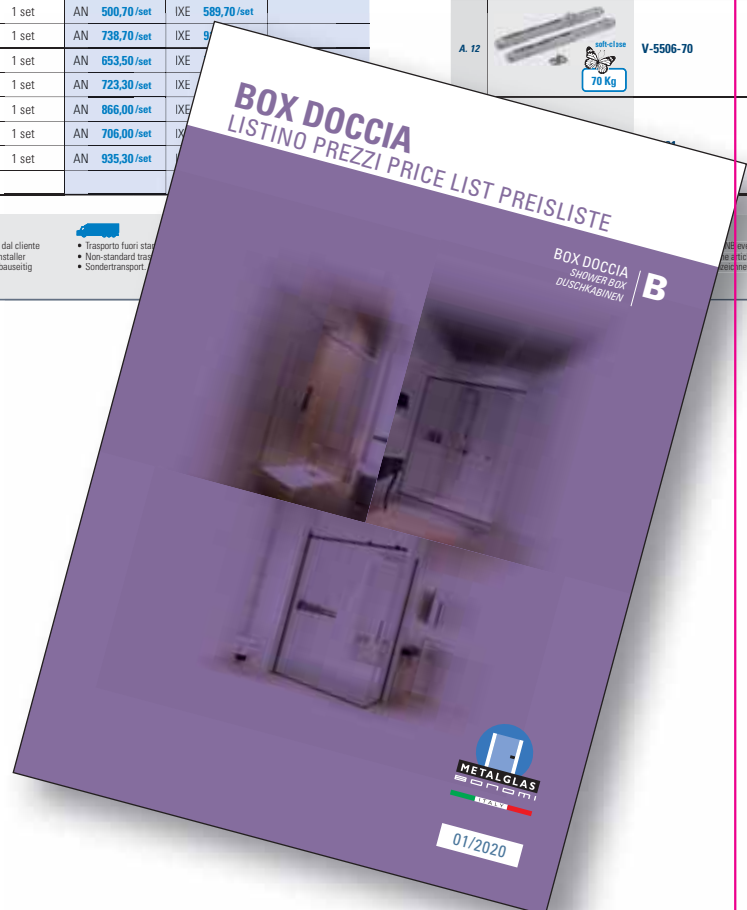

LEGENDA SIMBOLI

SYMBOL LEGEND

SYMBOLLEGENDE



8-10

SPESSORE VETRO
GLASS THICKNESS
GLASDICKE



ANTA SCORREVOLE
SLIDING DOOR
SCHIEBETÜR



1000

MISURE ANTA
PANEL MEASURES
TÜRGRÖSSE

FIX

LUNGHEZZA FISSA
FIXED LENGTH
FESTE LÄNGE



70 Kg

PORTATA
LOAD CAPACITY
TRAGKRAFT

MIS 

TAGLIATO A MISURA DEL CLIENTE
CUSTOM LENGTH
NACH MASS GESCHNITTEN



SISTEMA SOFT-CLOSE
SOFT-CLOSE SYSTEM
SOFT-CLOSE SYSTEM

MY METALGLAS

**CONFIGURATORE ESCLUSIVO
METALGLAS PER SEMPLIFICARE
LA REALIZZAZIONE DI SISTEMI
IN VETRO TEMPERATO**



70 Kg

PORTATA DEL SISTEMA SOFT-CLOSE
LOAD CAPACITY OF THE SOFT-CLOSE SYSTEM
TRAGKRAFT DES SOFT-CLOSE SYSTEMS

*EXCLUSIVE CONFIGURATOR METALGLAS
TO SIMPLIFY THE CREATION OF SYSTEMS
IN TEMPERED GLASS*

*EXKLUSIVER KONFIGURATOR METALGLAS
ZU VEREINFACHEN DIE ERSTELLUNG
VON SYSTEMEN AUS GEHÄRTETEM GLAS*

FIXED

ANTA FISSA
FIXED PANEL
SEITENTEIL

LEGENDA ABBREVIAZIONI

ACRONYM LEGEND











ERKLÄRUNG DER ABKÜRZUNGEN

L	PIATTO SHOWER TRAY DUSCHTASSE	LB	LUNGHEZZA BINARIO RAIL LENGTH LAUFSCHIENENLÄNGE
LP	PASSAGGIO LUCE CLEAR OPENING WIDTH LICHTE DURCHGANGSBREITE	HB	ALTEZZA FISSAGGIO BINARIO RAIL INSTALLATION HEIGHT LAUFSCHIENENMONTAGE HÖHE
H	ALTEZZA DOCCIA SHOWER HEIGHT DUSCHKABINEN HÖHE	LV	LARGHEZZA VETRO GLASS WIDTH GLAS BREITE
LM	LARGHEZZA ANTA MOBILE SLIDING DOOR WIDTH SCHIEBEFLÜGEL BREITE	HV	ALTEZZA VETRO GLASS HEIGHT GLAS HÖHE
HM / HA	ALTEZZA ANTA MOBILE SLIDING GLASS HEIGHT SCHIEBEFLÜGEL HÖHE	LV	LARGHEZZA VETRO GLASS WIDTH GLAS BREITE
HF	ALTEZZA ANTA FISSA SIDE FIXED GLASS HEIGHT SEITENTEIL HÖHE	HS	ALTEZZA STIPITE FRAME HEIGHT ZARGE HÖHE
LF	LARGHEZZA ANTA FISSA FIXED GLASS WIDTH SEITENTEIL BREITE	LS	LARGHEZZA STIPITE FRAME WIDTH ZARGE BREITE
HFL	ALTEZZA VETRO FISSO LATERALE SIDE FIXED GLASS HEIGHT SEITENTEIL (SEITLICH) HÖHE		

FINITURE

FINISHES

OBERFLÄCHEN

	CP CROMO PERLA CHROME PERLA SIMILAR ALU CHROM PERLA ÄHNLICH ALU		AN ALLUMINIO ANODIZZATO ALUMINIUM ANODIZED ALUMINIUM SILBERFARBIG
	CS CROMO SATINATO SATIN CHROME CHROM MATT		IX ACCIAIO INOX SATINATO SATIN STAINLESS STEEL EDELSTAHL MATT
	NS NICKEL SATINATO SATIN NICKEL ÄHNLICH EDELSTAHL MATT		IXE EFFETTO INOX SATINATO INOX EFFECT INOX EFFEKT
	CR CROMO LUCIDO POLISHED CHROME CHROM GLÄNZEND		IL ACCIAIO INOX LUCIDO POLISHED STAINLESS STEEL EDELSTAHL POLIERT
	OL OTTONE LUCIDO POLISHED BRASS MESSING POLIERT		NO NERO OPACO MATT BLACK SCHWARZ MATT

BOX DOCCIA
SHOWER BOX
DUSCHKABINEN

B

GUIDA TECNICA PER LA SCELTA DEL VOSTRO SISTEMA

TECHNICAL GUIDE FOR THE CHOICE OF YOUR SYSTEM

AUSWAHL VON SCHIEBETÜRSYSTEMEN NACH VORHANDENEN KRITERIEN

BOX DOCCIA CON SISTEMA SCORREVOLE
SHOWER BOX WITH SLIDING SYSTEM
DUSCHKABINEN MIT SCHIEBETÜRSYSTEM

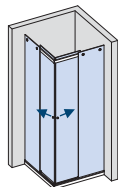

BX-6000 ETEREA
BX-6020 ETEREA
SOFT-CLOSE

▶ 18 **NEW**

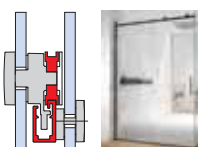

BX-4000 LINEA 30

▶ 34

NEW

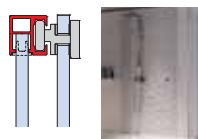

BX-3100 CON VELETTA
(OPTIONAL SOFT-CLOSE)

▶ 36

NEW



BX-1501

▶ 54

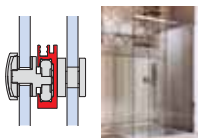

BX-2000

▶ 62

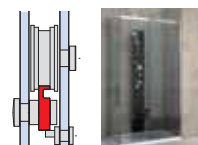

BX-01

▶ 70

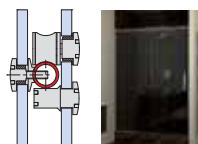

BX-02

▶ 80

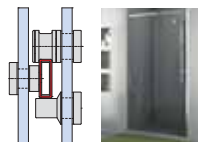

BOX DOCCIA SCORREVOLE A SOFFIETTO
SHOWER BOX WITH FOLDING DOOR
DUSCHKABINEN MIT SYSTEM FÜR FALTÜREN

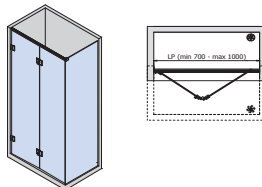

BX-2700

▶ 94

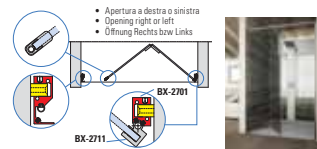

BX-2600

▶ 100

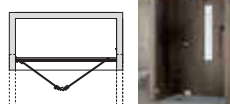

BOX DOCCIA CON ANTA A BATTENTE (CERNIERA A SCATTO)
SHOWER BOX WITH SWING DOOR (DOUBLE ACTION CLICKING HINGES)
DUSCHKABINEN MIT DREH-TÜR (SELBSTSCHLIESSENDE PENDELTÜRBÄNDER)

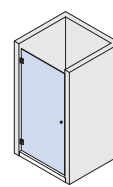

B-701 / B-702

▶ 107



B-702

▶ 107



B-301

▶ 109



B-306

▶ 109



B-100 / B-101

▶ 110



B-102 / B-103

▶ 110



B-150

▶ 111



B-400 / B-401

▶ 112



B-402 / B-405

▶ 112 - 113



L-220

▶ 109



CERNIERE A SCATTO IN BATTUTA
SINGLE ACTION CLICKING HINGES
FOR CONTINUOUS SEALS

ANSCHLAGTÜRBÄNDER
FÜR DURCHGEHENDE DICHTUNG
(SELBSTSCHLIESSENDE BÄNDER)

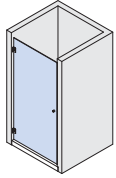

B-201

► 115



B-202

► 115



CERNIERE CON ALZATA IN APERTURA
HINGES WITH LIFT-LOWER FUNCTION
BÄNDER MIT HEBE-SENK-FUNKTION

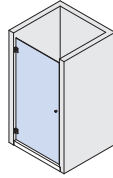

B-501 DX-SX

► 117



B-502 DX-SX

► 117



CERNIERE IN BATTUTA
(GUARNIZIONE CONTINUA)
HINGES FOR CONTINUOUS SEALS

ANSCHLAGTÜRBÄNDER
(DURCHGEHENDER DICHTUNG)

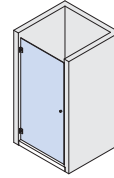

B-711

► 119

NEW



B-712

► 119

NEW



B-105

► 120



B-104

► 119



B-601 DX SX

► 120



B-602 DX-SX

► 120



GUIDA TECNICA PER LA SCELTA DEL VOSTRO SISTEMA

TECHNICAL GUIDE FOR THE CHOICE OF YOUR SYSTEM

AUSWAHL VON SCHIEBETÜRSYSTEMEN NACH VORHANDENEN KRITERIEN

**PIVOT ALTO-BASSO (BILICO)
PORTA BATTENTE**
TOP/BOTTOM PIVOT HINGES
OBERE/UNTERE PIVOT BÄNDER

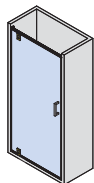

BX-2100 BILICO

▶ 122



B-304

▶ 126



BX-305

▶ 128



BX-303 BILICA

▶ 130



**PROFILI
PROFILES
PROFILE**

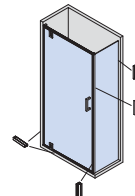

- PROFILI DI BATTUTA
 - DOOR STOP PROFILES
 - TÜRANSCHLAGSPROFIE
- ▶ 132



- ANGOLARI
 - L PROFILES
 - L PROFILE
- ▶ 135



- PROFILI GOCCIOLATOI
 - SPLASH GUARD PROFILES
 - SCHWALLSCHUTZ PROFILE
- ▶ 136



- CANALINE "U" CON ALETTA
 - U PROFILES WITH PLATE
 - U-PROFILE MIT PLATTE
- ▶ 143



- GUIDE A PAVIMENTO
 - FLOOR GUIDES
 - BODENFÜHRUNGEN
- ▶ 139



- CANALINE "U" IN ALLUMINIO
 - U PROFILES IN ALUMINIUM
 - U-PROFILE AUS ALUMINIUM
- ▶ 140



- CANALINE IN ACCIAIO
 - "U" PROFILES IN INOX
 - "U" PROFILE AUS INOX
- ▶ 130



- CANALINE "U" CON BORDO RIPIEGATO
 - U PROFILES WITH FOLDED EDGE U-PROFILE
 - "U" PROFILE MIT ABGERUNDETER KANTE
- ▶ 142



SEPARÉ
SEPARÉ
SEPARÉ

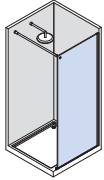

- BARRE DI SUPPORTO QUADRE REGOLABILI
- ADJUSTABLE SQUARE SUPPORT BARS
- VERSTELLBARE ECKIGE STABILISATIONSSTANGEN



► 140

- BARRE DI SUPPORTO QUADRE
- SQUARE SUPPORT BARS
- ECKIGE STABILISATIONSSTANGEN



► 144

- BARRE DI SUPPORTO TONDE
- ROUND SUPPORT BARS
- RUNDE STABILISATIONSSTANGEN



► 153

ACCESSORI
ACCESSORIES
ZUBEHÖRE

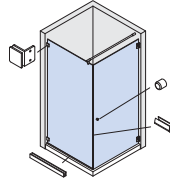

- MORSETTI
- CLAMPS
- KLEMMBESCHLÄGE

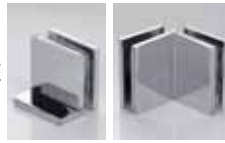

► 160

- RAGNETTI
- CONNECTORD
- VERBINDER



► 164

- GUARNIZIONI
- GASKETS
- DICHTUNGEN



► 166

- POMOLI, NICCHIE E MANIGLIONI
- KNOBS, SLIDING HANDLES, HANDLES
- KNÖPFE, GRIFFMUSCHELN, STOSSGRIFFE

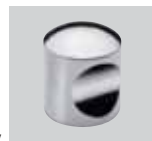

► 172

BOX DOCCIA CON SISTEMA SCORREVOLE

SHOWER BOX WITH SLIDING SYSTEM / DUSCHKABINEN MIT SCHIEBETÜRSYSTEM



BX-6000
BX-6020
SOFT-CLOSE



► 18

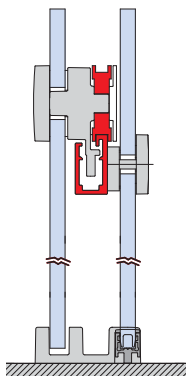

BX-4000 LINEA 30

► 34

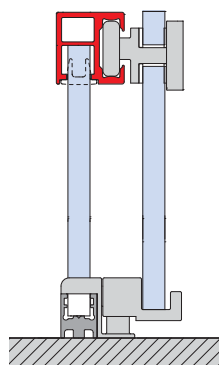

BX-3100 CON VELETTA
(OPTIONAL SOFT-CLOSE)

► 44

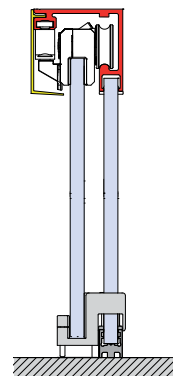

BX-1501

► 54

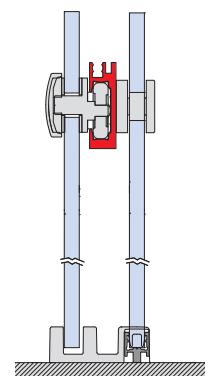



BX-2000

► 62

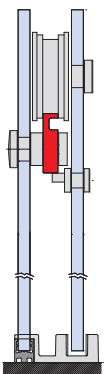

BX-01

► 70

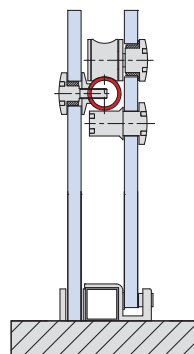

BX-02

► 80

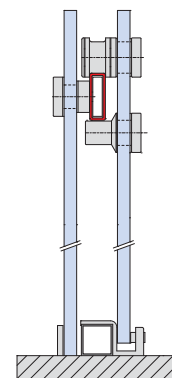

SCORREVOLI

GUIDA TECNICA PER LA SCELTA DEL TUO "PROFILO A TERRA" SECONDO TIPOLOGIE

TECHNICAL GUIDE FOR THE CHOICE OF YOUR "FLOOR PROFILE" BY TYPOLOGIES

AUSWAHL VON "BODENPROFIL" NACH VORHANDENEN KRITERIEN

Per i modelli: / For models: / Für Modelle:
BX-1501, BX-4000, BX-6000, BX-6020,
BX-3100, BX-2000

SET 1

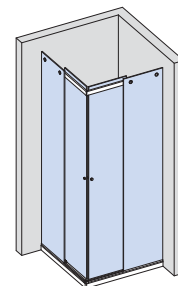

SCORREVOLI



BX-PT-01 STANDARD

- Vetro fisso nel profilo continuo H 16 mm.
- Fixed glass in shower entry floor profile H 16 mm.
- Festverglasung im Duscheinstieg Bodenprofil H 16 mm.

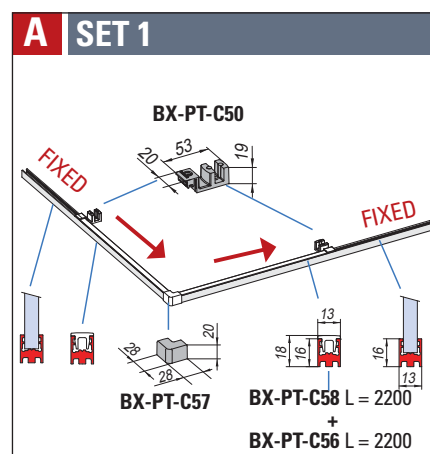
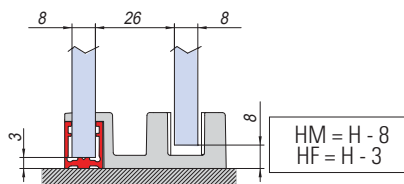

BX-PT-02 SOLO PORTA OPTIONAL

- Vetro fisso su piatto doccia, solo profilo entrata H 16 mm.
- Fixed glass on shower tray, only shower entry floor profile H 16 mm.
- Festverglasung auf Duschtasse, Duscheinstieg Bodenprofil H 16 mm.

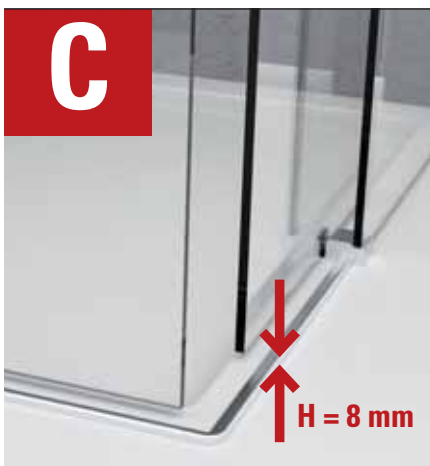
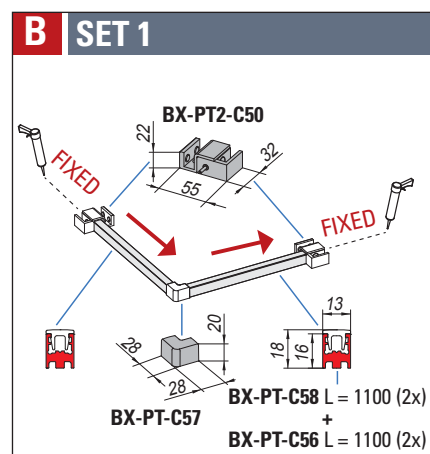
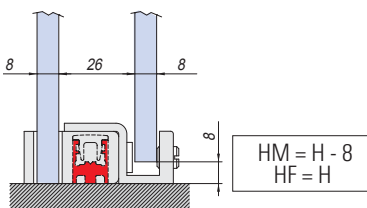

BX-PT-03 RASO DOCCIA OPTIONAL

- Vetro fisso su piatto doccia, profilo entrata H 8 mm.
- Fixed glass on shower tray, shower entry floor profile H 8 mm.
- Festverglasung auf Duschtasse, Duscheinstieg Bodenprofil H 8 mm.

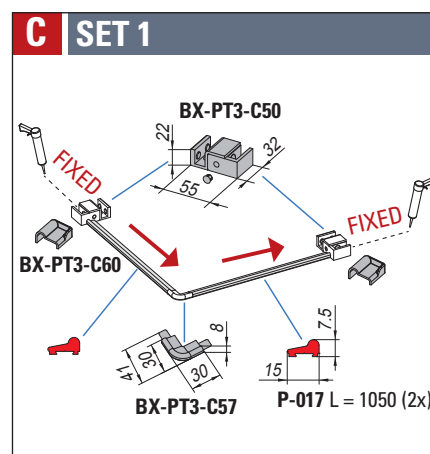
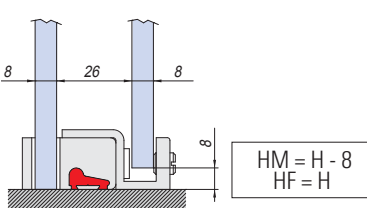

SCEGLIERE FONDO PREFERITO

CHOOSE FAVORITE FLOOR PROFILES / WÄHLEN SIE IHR GEWÜNSCHTES BODENPROFIL

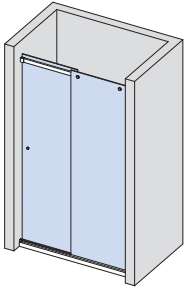
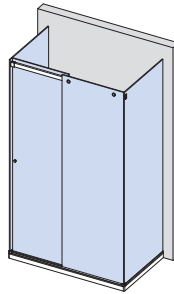
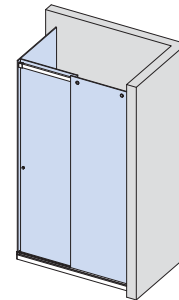
SET 2

SET 3

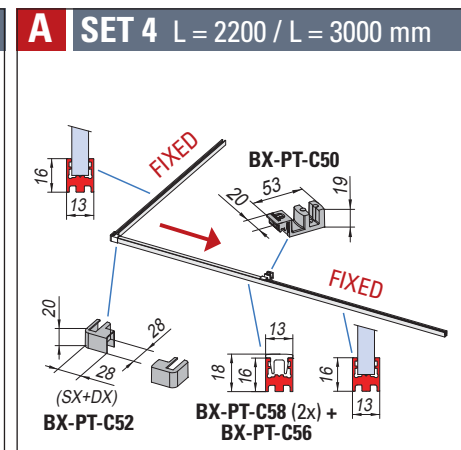
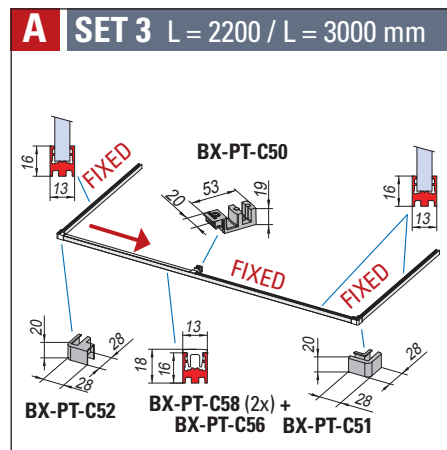
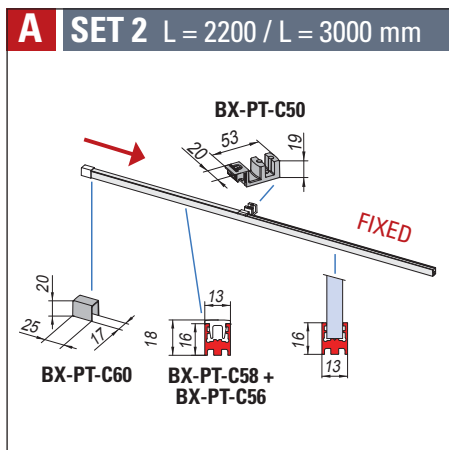
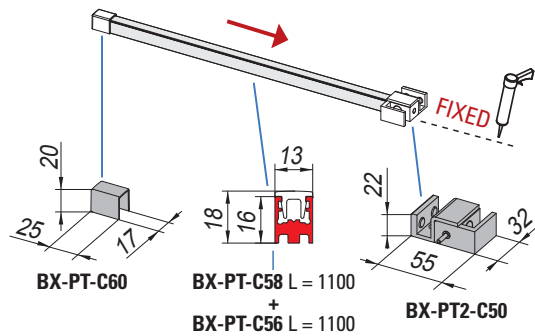
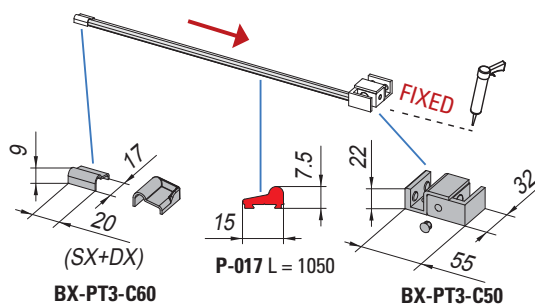
SET 4

SCORREVOLI

B SET 2
B SET 3
B SET 4

C SET 2
C SET 3
C SET 4

HM
 Altezza vetro mobile
 Sliding glass height
 Schiebeflügel Höhe

HF
 Altezza vetro fisso
 Side fixed glass height
 Seitenteil Höhe

VISTA ESTERNA
EXTERNAL VIEW



SCORREVOLI

VISTA INTERNA
INTERNAL VIEW



BX-6000 ETEREA

VEDRAI L'USUALE CON OCCHI DIVERSI

Con Eterea ci siamo accorti che per noi innovare è consuetudine. Volevamo semplificare un prodotto classico per renderlo il più possibile minimale, bello ed accattivante, ed alla fine abbiamo fatto "scompare tutto".

PER IL SUO DESIGN E PER L'INNOVAZIONE CHE LA CONTRADDISTINGUE ETEREA SI CANDIDA AD ESSERE LA MIGLIORE SUL MERCATO.

YOU WILL SEE THE USUAL WITH DIFFERENT EYES

With Eterea we realised that it is customary for us to innovate. We set out to simplify a classic product to make it as minimal, beautiful and as alluring as possible, and ultimately we made "everything disappear". Due to its design and the innovation that distinguishes it, Eterea boasts it is the best on the market.

SIE WERDEN DAS NORMALE MIT ANDEREN AUGEN BETRACHTEN

Mit Eterea haben wir bemerkt, dass Innovation für uns üblich ist. Wir wollten ein klassisches Produkt vereinfachen, um es möglichst minimal zu gestalten, schön und attraktiv, und schließlich haben wir „alles verschwinden lassen“. Aufgrund des herausragenden Designs und der Innovation konkurriert Eterea, um die Beste auf dem Markt zu werden.

BOX DOCCIA

MODELLO TRADIZIONALE

TRADITIONAL SHOWER ENCLOSURE MODEL
TRADITIONELLES DUSCHKABINENMODELL

INVISIBILE IN
ETEREA
BX-6000

INVISIBILE IN ETEREA BX-6000
UNSICHTBAR ETEREA BX-6000

SCORREVOLI

NEW

PLUS

- NESSUNO STOPPER A VISTA
- NESSUNA BORCHIA PER L'AGGANCIAMENTO DEL VETRO FISSO A VISTA
- SISTEMA ANTISOLLEVAMENTO DI SICUREZZA INVISIBILE
- SISTEMA OPZIONALE DI CHIUSURA "SOFT-CLOSE"
- SISTEMA STANDARD DI CHIUSURA AMMORTIZZATA
- PROFILO INTERNO DOCCIA PRIVO DI ACCESSORI A VISTA

- No visible stopper
- No stud for coupling of the visible fixed glass panel
- Invisible safety anti-lift system
- Optional soft-close closing system.
- Standard cushioned closing system
- Shower internal profile without visible accessories

- Kein sichtbarer Stopper
- Keine Nieten zum Fixieren des Glases sichtbar
- Unsichtbare Sicherung gegen das Hochschieben
- Ein optionales Schließsystem soft-close.
- Ein gedämpftes Standard-Schließsystem
- Innenprofil der Dusche ohne sichtbares Zubehör

BX-6000 / BX-6020 SOFT-CLOSE



- Profilo completamente libero e semplificazione della pulizia, quindi eliminazione totale di depositi e residui dovuti al normale utilizzo. Costruita in alluminio è disponibile nelle finiture cromo lucido e nero opaco.
- A completely free profile also means simplification of cleaning, therefore complete elimination of deposits and residues due to normal use. Made of aluminium, it is available in polished chrome and matt black finishes.
- Ein vollständig freies Profil bedeutet auch vereinfachte Reinigung, daher werden Ablagerungen und Rückstände durch normalen Gebrauch komplett beseitigt. Hergestellt aus Aluminium und ist mit Oberflächen in Chrom glänzend und matt schwarz erhältlich.



SCOREVOLI



SET 1 e▶ B.01
e▶ B.07

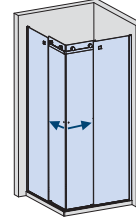

SET 2 e▶ B.02
e▶ B.08

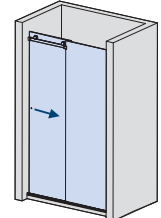

SET 3 e▶ B.03
e▶ B.09

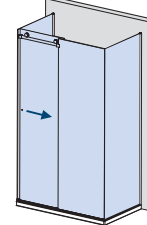

SET 4 e▶ B.04
e▶ B.10

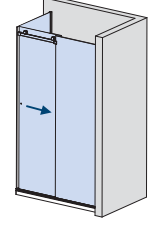

SET 5 e▶ B.11

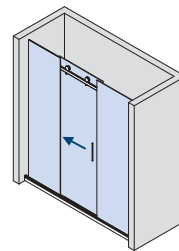

SCORREVOLI

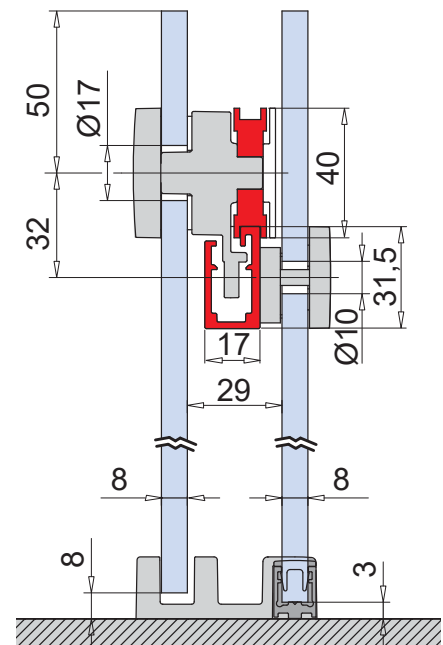

BX-6000 SET 1

L = 1000 x 1000mm

DOCCIA IN ANGOLO / CORNER SHOWER / ECKDUSCHE

MY METALGLAS

e▶ B.01

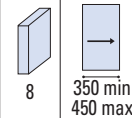

Fin. / Fin. / Oberf.

CR	NO
Cromo lucido	Nero opaco
Polished chrome	Matt black
Chrom glänzend	Matt schwarz

COMPONENTI / COMPONENTS / EINZELTEILE

- BX-6000-C30 (2x)
- BX-6000-C10 (4x)
- BX-6000-C90 (2x)
- BX-6000-C70-2 (2x)
- BX-6000-C20 (1x)
- OPTIONAL B-136/BX-PF-01 (1x)
- OPTIONAL

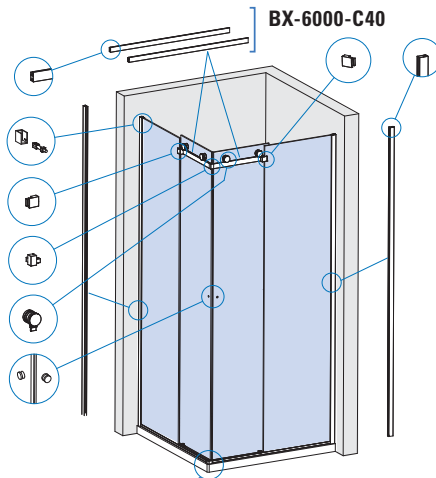

CARATTERISTICHE COMPONENTI / FEATURES COMPONENTS / EIGENSCHAFTEN EINZELTEILE ▶ 22

- Obbligatorio fissaggio a parete tramite profili a "U" o morsetti (non inclusi)
- Necessary wall-mounting with "U" profiles or clamps (not included)
- Verbindliche Befestigung an der Wand mit „U“-Profilen oder Wandhaltern (nicht inbegriffen)

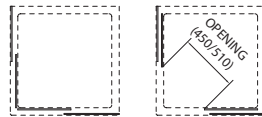
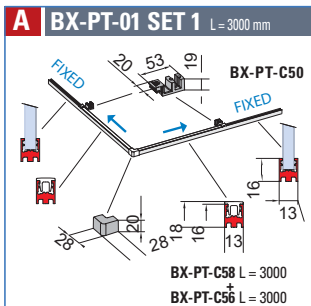

PROFILI A TERRA / FLOOR PROFILES / BODENPROFILE ▶ 88

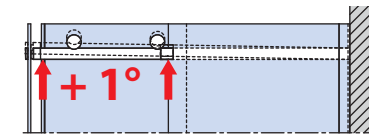

BX-6020 SOFT-CLOSE SET 1

L = 1000 x 1000mm

DOCCIA IN ANGOLO / CORNER SHOWER / ECKDUSCHE



MY METALGLAS

e▶ B.07

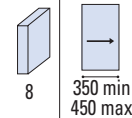

Fin. / Fin. / Oberf.

CR	NO
Cromo lucido	Nero opaco
Polished chrome	Matt black
Chrom glänzend	Matt schwarz

COMPONENTI / COMPONENTS / EINZELTEILE

- BX-6000-SOFT-CLOSE (2x)
- BX-6000-C10 (2x)
- BX-6000-C12 (2x)
- BX-6000-C90 (2x)
- BX-6000-C70-2 (2x)
- BX-6000-C20 (1x)
- OPTIONAL B-136/BX-PF-01 (1x)
- OPTIONAL

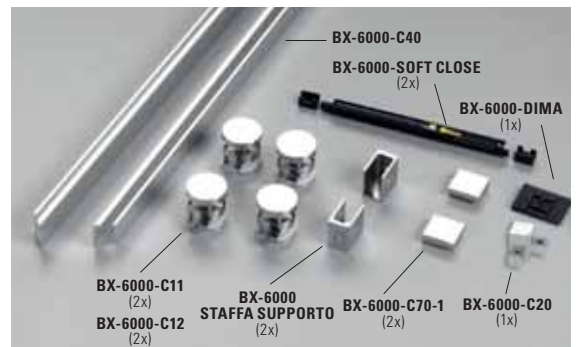
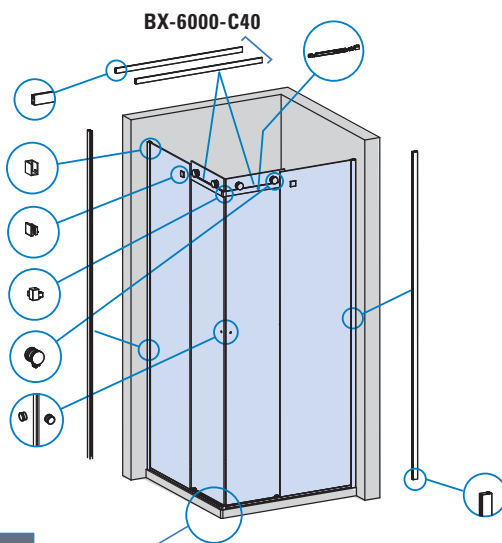

CARATTERISTICHE COMPONENTI / FEATURES COMPONENTS / EIGENSCHAFTEN EINZELTEILE ▶ 22

- Obbligatorio fissaggio a parete tramite profili a "U" o morsetti (non inclusi)
- Necessary wall-mounting with "U" profiles or clamps (not included)
- Verbindliche Befestigung an der Wand mit „U“-Profilen oder Wandhaltern (nicht inbegriffen)

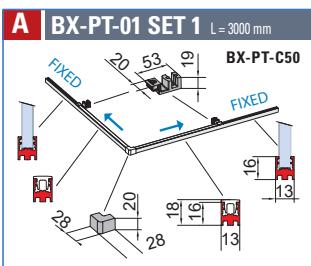

PROFILI A TERRA / FLOOR PROFILES / BODENPROFILE ▶ 88

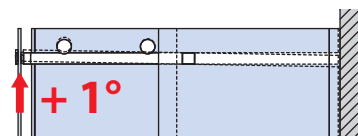

LAVORAZIONE VETRO / GLASS PREPARATION / GLASBEARBEITUNG

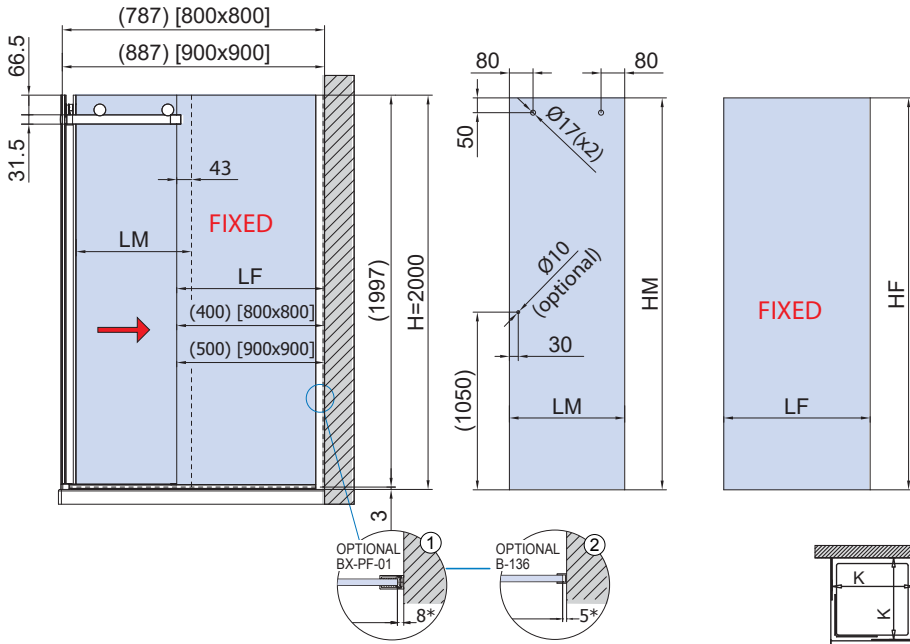

CALCOLO VETRO / CALCULATION GLASS / GLASBERECHNUNG

PIATTO - SHOWER TRAY - DUSCHASSE (L) = 800x800 (900x900) mm

Vetro Mobile Larghezza (LM) = L / 2

Vetro Fisso Larghezza (LF) = [(L / 2)] - * ① / * ② (aria variabile / clearance / Spaltmaß)

Vetro Mobile Altezza (HM) = H - 8 = 1992 mm

PROFILI A TERRA / FLOOR PROFILES / BODENPROFILE ▶ 88

A BX-PT-01 STANDARD HF = H - 3 = 1997 mm

xme556a

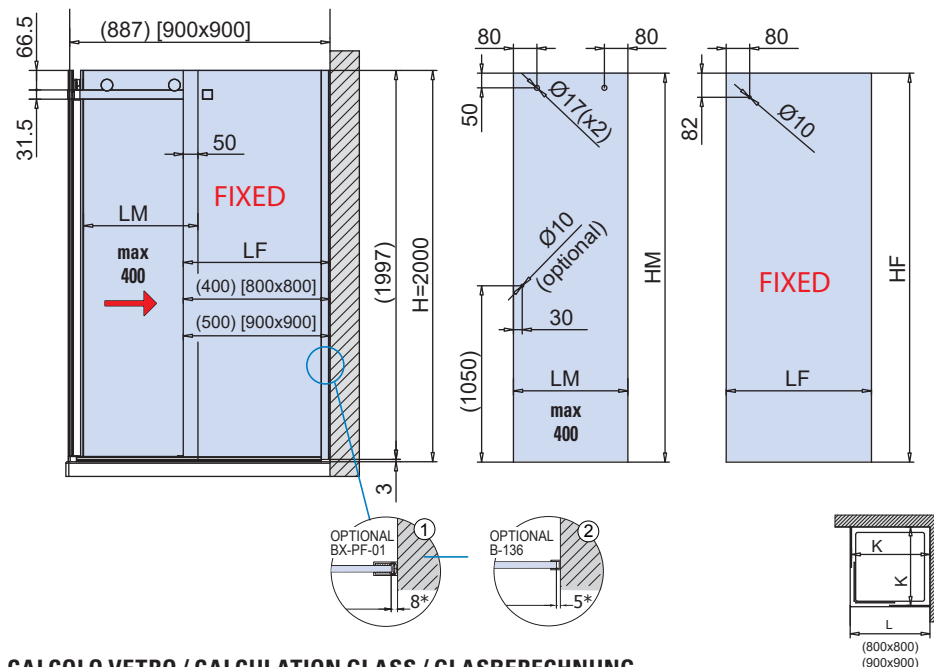

CALCOLO VETRO / CALCULATION GLASS / GLASBERECHNUNG

PIATTO - SHOWER TRAY - DUSCHASSE (L) = 800x800 (900x900) mm

Vetro Mobile Larghezza (LM) = L / 2

Vetro Fisso Larghezza (LF) = [(L / 2)] - * ① / * ② (aria variabile / clearance / Spaltmaß)

Vetro Mobile Altezza (HM) = H - 8 = 1992 mm

PROFILI A TERRA / FLOOR PROFILES / BODENPROFILE ▶ 88

A BX-PT-01 STANDARD HF = H - 3 = 1997 mm

xme556b

SET 1

DA TAGLIARE / ADJUST THE LENGTH / BELIEBIG KÜRZBAR ✂

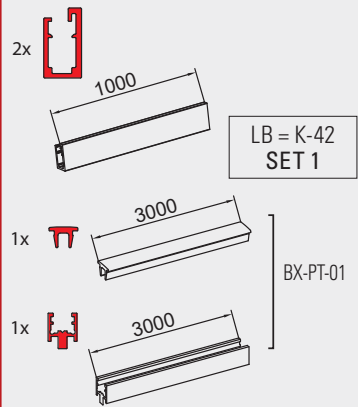

- Regolazione ± 2 mm.
- Adjustment ± 2 mm.
- Verstellung ± 2 mm.

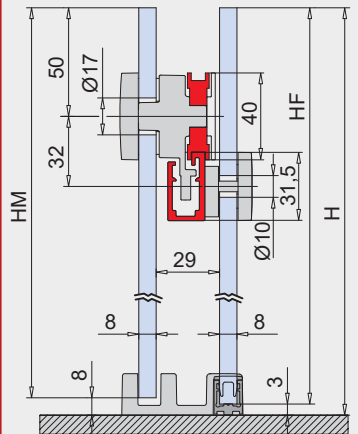

HM = H - 8
 HF = H - 3
 solo per / only for / nur für
A BX-PT-01

OPTIONAL



L	LP	LM	LF	HM	HF	H
Piatto Shower tray Duschasse	Passaggio luce Clear opening width Lichte Durchgangsbreite	Larghezza vetro mobile Sliding glass width Schiebeflügel Breite	Larghezza vetro fisso Side fixed glass width Seitenteil Breite	Altezza vetro mobile Sliding glass height Schiebeflügel Höhe	Altezza vetro fisso Side fixed glass height Seitenteil Höhe	Altezza doccia Shower height Duschcabinen Höhe

BX-6000 SET 2 DX / BX-6000 SET 2 SX

MY METALGLAS

L = 1500mm / L = 3000mm

DOCCIA IN NICCHIA / NICHE SHOWER / NISCHENDUSCHE

e▶ B.02

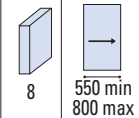

Fin. / Fin. / Oberf.

CR	NO
Cromo lucido	Nero opaco
Polished chrome	Matt black
Chrom glänzend	Matt schwarz

COMPONENTI / COMPONENTS / EINZELTEILE

- BX-6000-C30** (1x)
- BX-6000-C10** (2x)
- BX-6000-C90** (2x)
- BX-6000-C70-2** (1x)
- OPTIONAL**
B-136/BX-PF-01 (1x)
- OPTIONAL**

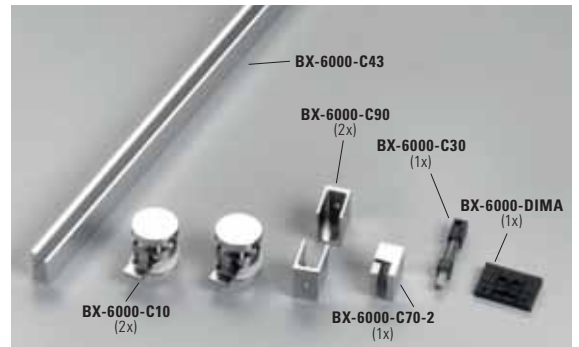
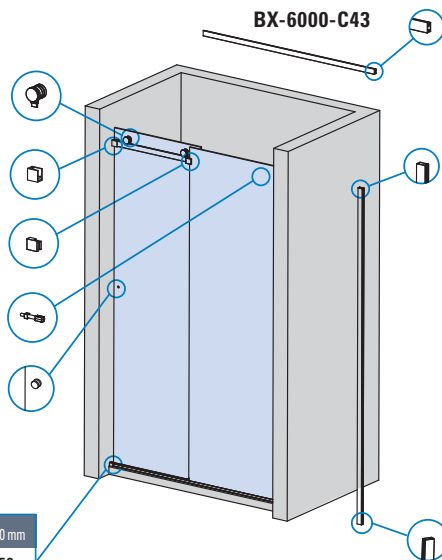

CARATTERISTICHE COMPONENTI /
FEATURES COMPONENTS /
EIGENSCHAFTEN EINZELTEILE ▶ 22

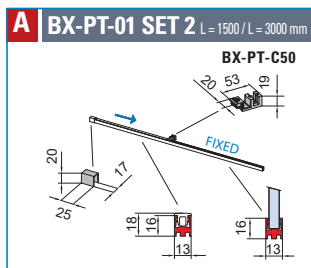

PROFILI A TERRA / FLOOR PROFILES / BODENPROFILE ▶ 88

xme556c

- Obbligatorio fissaggio a parete tramite profili a "U" o morsetti (non inclusi)
- Necessary wall-mounting with "U" profiles or clamps (not included)
- Verbindliche Befestigung an der Wand mit „U“-Profilen oder Wandhaltern (nicht inbegriffen)

BX-6020 SOFT-CLOSE SET 2



MY METALGLAS

L = 1500mm / L = 3000mm

DOCCIA IN NICCHIA / NICHE SHOWER / NISCHENDUSCHE

e▶ B.08

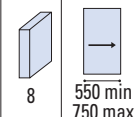

Fin. / Fin. / Oberf.

CR	NO
Cromo lucido	Nero opaco
Polished chrome	Matt black
Chrom glänzend	Matt schwarz

COMPONENTI / COMPONENTS / EINZELTEILE

- BX-6000-SOFT-CLOSE** (1x)
- BX-6000-C11** (1x)
- BX-6000-C12** (1x)
- BX-6000-C90** (2x)
- BX-6000-C70-1** (1x)
- OPTIONAL**
B-136/BX-PF-01 (1x)
- OPTIONAL**

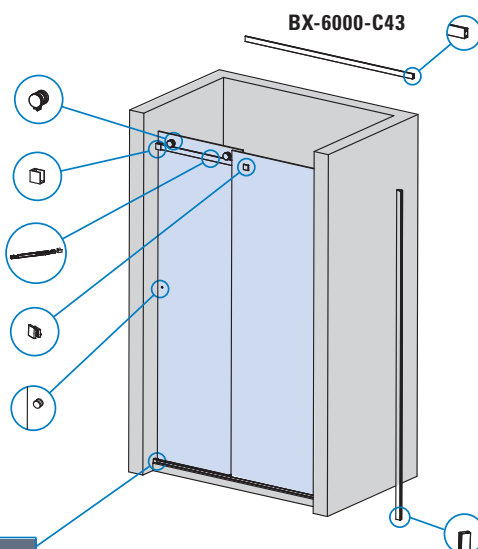

CARATTERISTICHE COMPONENTI /
FEATURES COMPONENTS /
EIGENSCHAFTEN EINZELTEILE ▶ 22

- Obbligatorio fissaggio a parete tramite profili a "U" o morsetti (non inclusi)
- Necessary wall-mounting with "U" profiles or clamps (not included)
- Verbindliche Befestigung an der Wand mit „U“-Profilen oder Wandhaltern (nicht inbegriffen)

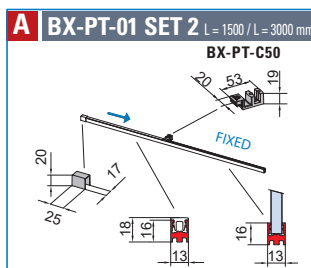

PROFILI A TERRA / FLOOR PROFILES / BODENPROFILE ▶ 88

xme556d

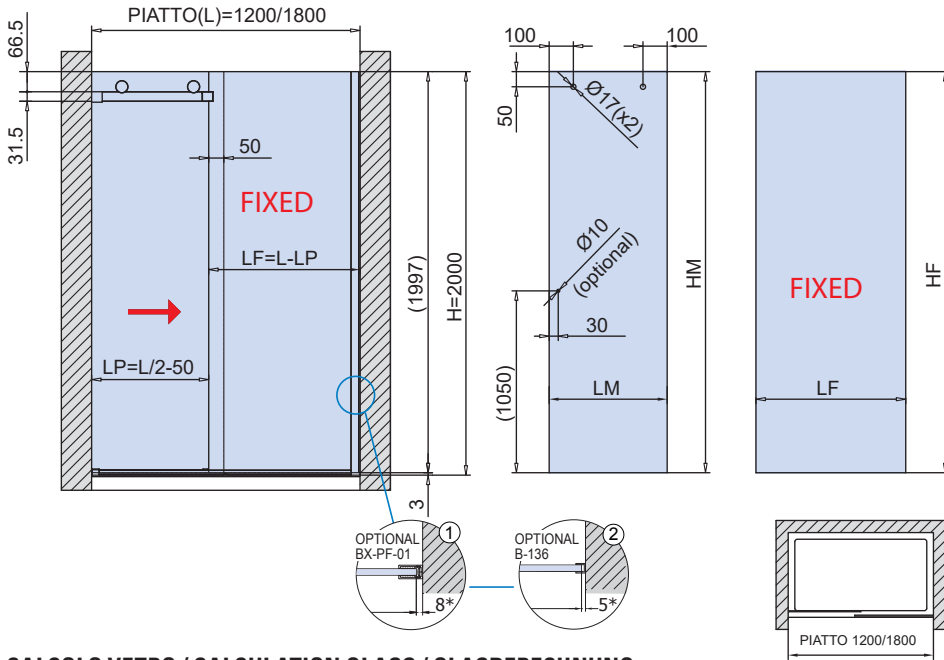
LAVORAZIONE VETRO / GLASS PREPARATION / GLASBEARBEITUNG

CALCOLO VETRO / CALCULATION GLASS / GLASBERECHNUNG

PIATTO - SHOWER TRAY - DUSCHTASSE (L) = 1200 - 1800 mm
 Passaggio (LP) = L / 2 - 50
 Vetro Mobile Larghezza (LM) = LP + 45
 Vetro Fisso Larghezza (LF) = L - LP - * ① / * ② (aria variabile / clearance / Spaltmaß)
 Vetro Mobile Altezza (HM) = H - 8 = 1992 mm

PROFILI A TERRA / FLOOR PROFILES / BODENPROFILE ▶ 88

BX-PT-01 STANDARD HF = H - 3 = 1997 mm

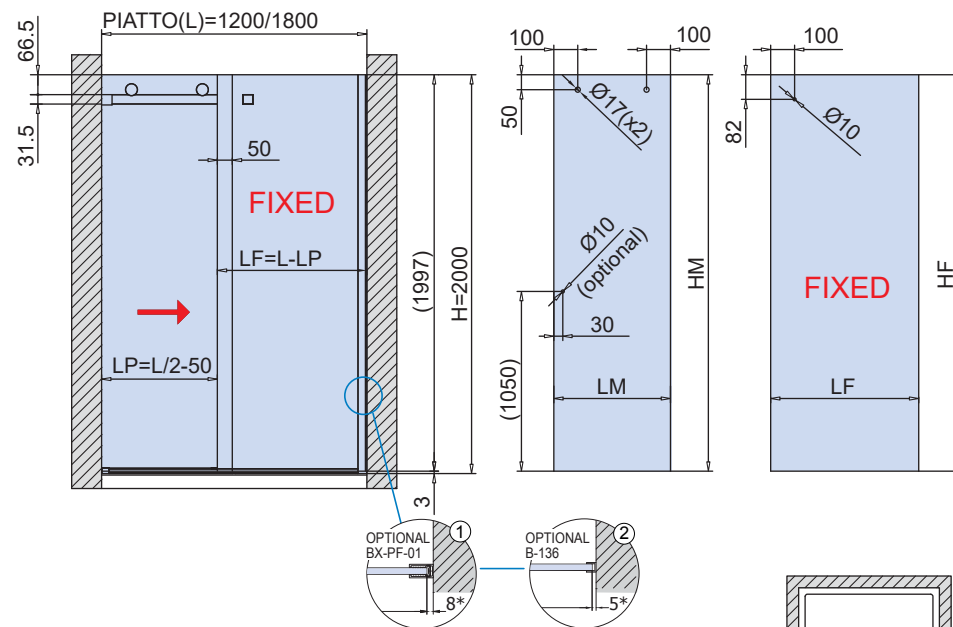
xme556c

CALCOLO VETRO / CALCULATION GLASS / GLASBERECHNUNG

PIATTO - SHOWER TRAY - DUSCHTASSE (L) = 1200 - 1800 mm
 Passaggio (LP) = L / 2 - 50
 Vetro Mobile Larghezza (LM) = LP + 45
 Vetro Fisso Larghezza (LF) = L - LP - * ① / * ② (aria variabile / clearance / Spaltmaß)
 Vetro Mobile Altezza (HM) = H - 8 = 1992 mm

PROFILI A TERRA / FLOOR PROFILES / BODENPROFILE ▶ 88

BX-PT-01 STANDARD HF = H - 3 = 1997 mm

xme556d

SET 2

DA TAGLIARE / ADJUST THE LENGTH / BELIEBIG KÜRZBAR ✂

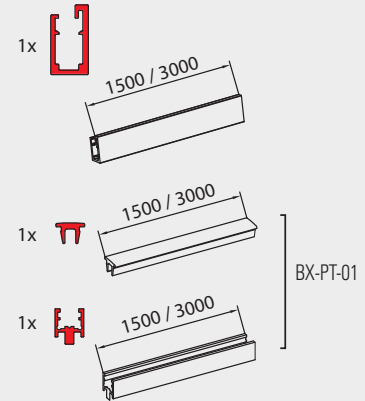

- Regolazione ± 2 mm.
- Adjustment ± 2 mm.
- Verstellung ± 2 mm.

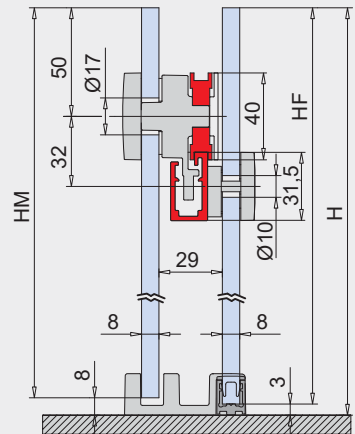

HM = H - 8
 HF = H - 3
 solo per / only for / nur für **BX-PT-01**

OPTIONAL

L	LP	LM	LF	HM	HF	H	HFL
Piatto	Passaggio luce	Larghezza vetro mobile	Larghezza vetro fisso	Altezza vetro mobile	Altezza vetro fisso	Altezza doccia	Altezza vetro fisso laterale
Shower tray	Clear opening width	Sliding glass width	Side fixed glass width	Sliding glass height	Side fixed glass height	Shower height	Side fixed glass height
Duschtasse	Lichte Durchgangsbreite	Schiebeflügel Breite	Seitenteil Breite	Schiebeflügel Höhe	Seitenteil Höhe	Duschcabinen Höhe	Seitenteil (seitlich) Höhe

SCORREVOLI

BX-6000 SET 3 DX / BX-6000 SET 3 SX

MY METALGLAS

L = 1500mm / L = 3000mm

DOCCIA A U / U SHOWER / U DUSCHE

e▶ B.03

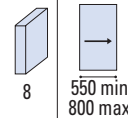

Fin. / Fin. / Oberf.

CR	NO
Cromo lucido	Nero opaco
Polished chrome	Matt black
Chrom glänzend	Matt schwarz

COMPONENTI / COMPONENTS / EINZELTEILE

- BX-6000-C30** (1x)
- BX-6000-C10** (2x)
- BX-6000-C90** (2x)
BX-6000-C81 (2x)
- BX-6000-C70-2** (1x)
- BX-6000-C70-1** (1x)
- OPTIONAL**
B-136/BX-PF-01 (1x)
- OPTIONAL**

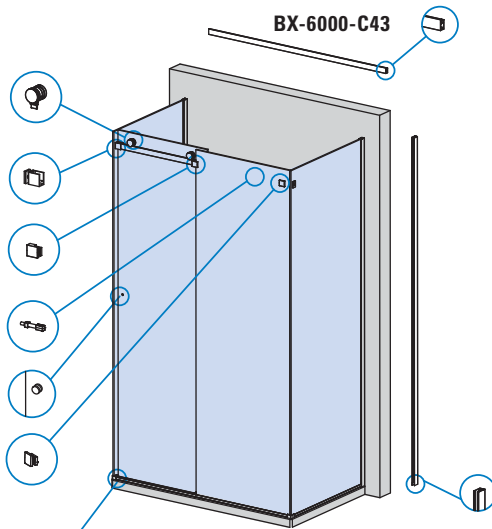

CARATTERISTICHE COMPONENTI / FEATURES COMPONENTS / EIGENSCHAFTEN EINZELTEILE ▶ 22



- Obbligatorio fissaggio a parete tramite profili a "U" o morsetti (non inclusi)
- Necessary wall-mounting with "U" profiles or clamps (not included)
- Verbindliche Befestigung an der Wand mit „U“-Profilen oder Wandhaltern (nicht inbegriffen)

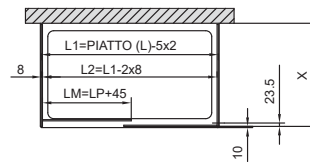
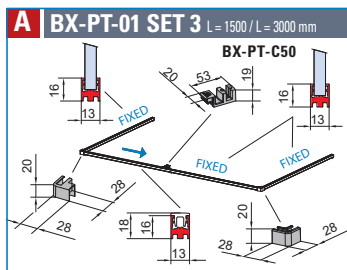

PROFILI A TERRA / FLOOR PROFILES / BODENPROFILE ▶ 88

xme556e

BX-6020 SOFT-CLOSE SET 3



MY METALGLAS

L = 1500mm / L = 3000mm

DOCCIA A U / U SHOWER / U DUSCHE

e▶ B.09

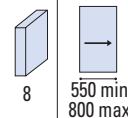

Fin. / Fin. / Oberf.

CR	NO
Cromo lucido	Nero opaco
Polished chrome	Matt black
Chrom glänzend	Matt schwarz

COMPONENTI / COMPONENTS / EINZELTEILE

- BX-6000-SOFT-CLOSE** (1x)
- BX-6000-C11** (1x)
- BX-6000-C12** (1x)
- BX-6000-C90** (2x)
BX-6000-C81 (2x)
- BX-6000-C70-1** (2x)
- OPTIONAL**
B-136/BX-PF-01 (2x)
- OPTIONAL**

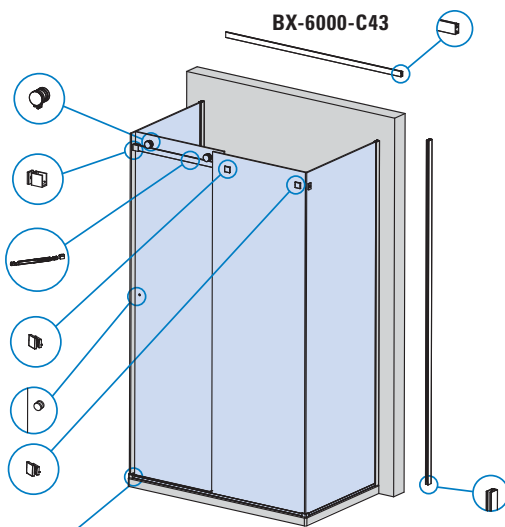

CARATTERISTICHE COMPONENTI / FEATURES COMPONENTS / EIGENSCHAFTEN EINZELTEILE ▶ 22

- Obbligatorio fissaggio a parete tramite profili a "U" o morsetti (non inclusi)
- Necessary wall-mounting with "U" profiles or clamps (not included)
- Verbindliche Befestigung an der Wand mit „U“-Profilen oder Wandhaltern (nicht inbegriffen)

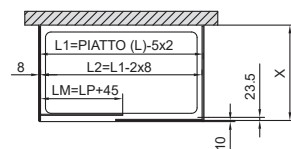
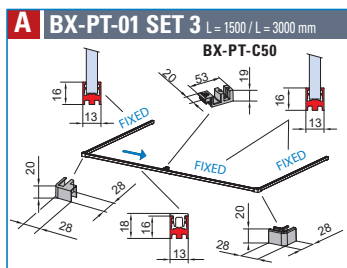

PROFILI A TERRA / FLOOR PROFILES / BODENPROFILE ▶ 88

xme556f

LAVORAZIONE VETRO / GLASS PREPARATION / GLASBEARBEITUNG

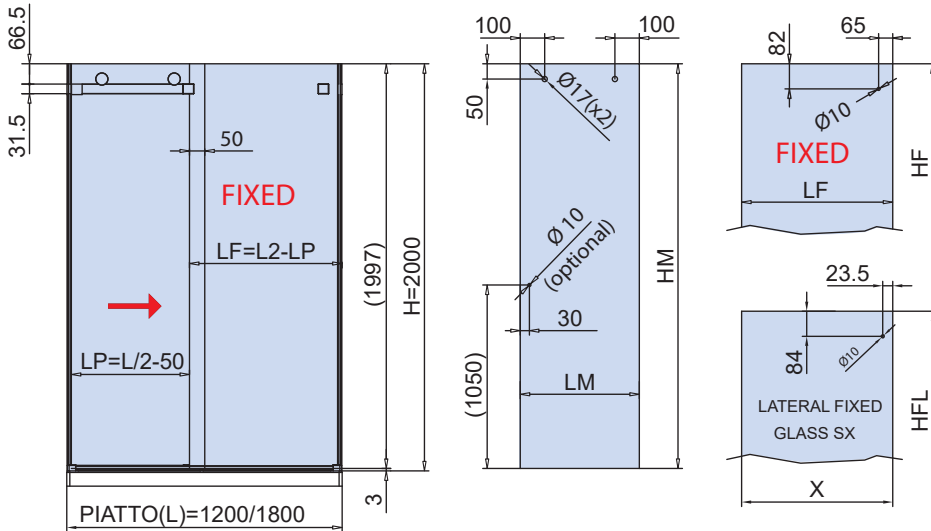

CALCOLO VETRO / CALCULATION GLASS / GLASBERECHNUNG

PIATTO - SHOWER TRAY - DUSCHTASSE (L) = 1200 - 1800 mm

$L1 = PIATTO (L) - 5 \times 2$

$L2 = L1 - 2 \times 8$

Passaggio (LP) = $L2 / 2 - 50$

Vetro Mobile Larghezza (LM) = $LP + 45$

Vetro Fisso Larghezza (LF) = $L2 - LP$

X = CALCOLARE / CALCULATE / BERECHNEN

Vetro Mobile Altezza (HM) = $H - 8 = 1992$ mm

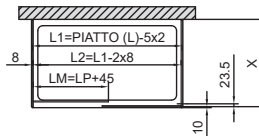

PROFILI A TERRA / FLOOR PROFILES / BODENPROFILE ▶ 88

A BX-PT-01 STANDARD HF = $H - 3 = 1997$ mm HFL = $H - 3$

xme556e

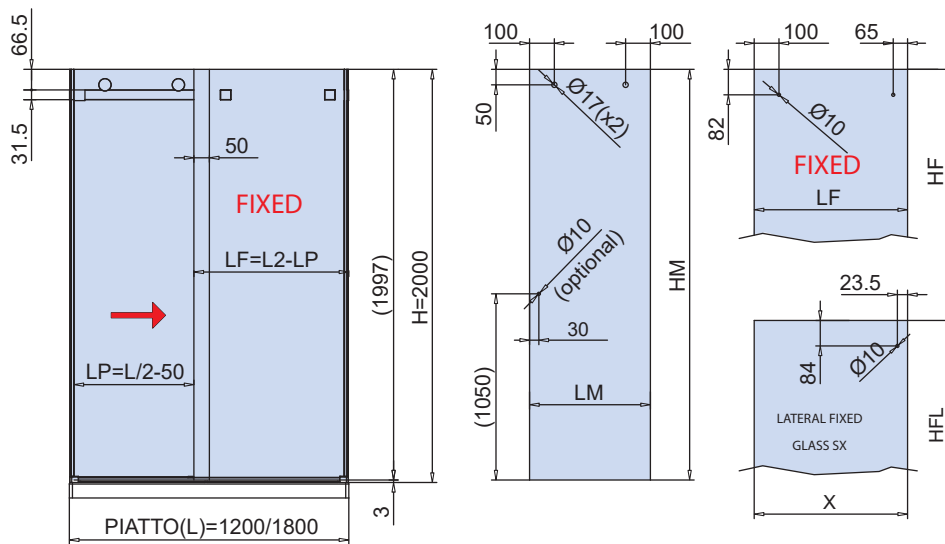

CALCOLO VETRO / CALCULATION GLASS / GLASBERECHNUNG

PIATTO - SHOWER TRAY - DUSCHTASSE (L) = 1200 - 1800 mm

$L1 = PIATTO (L) - 5 \times 2$

$L2 = L1 - 2 \times 8$

Passaggio (LP) = $L2 / 2 - 50$

Vetro Mobile Larghezza (LM) = $LP + 45$

Vetro Fisso Larghezza (LF) = $L2 - LP$

X = CALCOLARE / CALCULATE / BERECHNEN

Vetro Mobile Altezza (HM) = $H - 8 = 1992$ mm

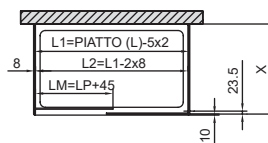

PROFILI A TERRA / FLOOR PROFILES / BODENPROFILE ▶ 88

A BX-PT-01 STANDARD HF = $H - 3 = 1997$ mm HFL = $H - 3$

xme556f

SET 3

DA TAGLIARE / ADJUST THE LENGTH / BELIEBIG KÜRZBAR ✂

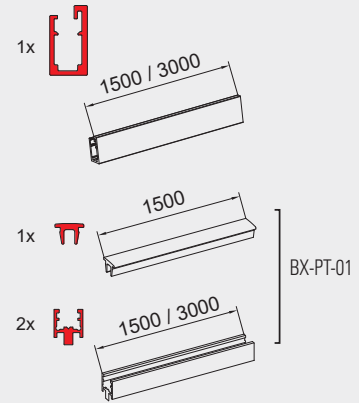

- Regolazione ± 2 mm.
- Adjustment ± 2 mm.
- Verstellung ± 2 mm.

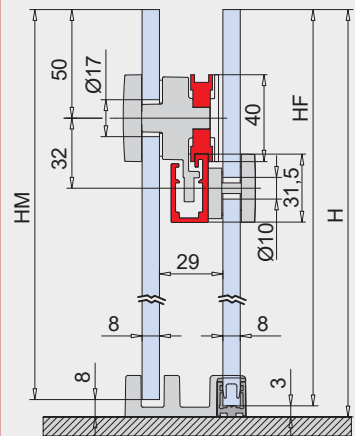

$HM = H - 8$
 $HF = H - 3$
 solo per / only for / nur für **BX-PT-01**

OPTIONAL



L	LP	LM	LF	HM	HF	H	HFL
Piatto Shower tray Duschtaße	Passaggio luce Clear opening width Lichte Durchgangsbreite	Larghezza vetro mobile Sliding glass width Schiebefügel Breite	Larghezza vetro fisso Side fixed glass width Seitenteil Breite	Altezza vetro mobile Sliding glass height Schiebefügel Höhe	Altezza vetro fisso Side fixed glass height Seitenteil Höhe	Altezza doccia Shower height Duschcabine Höhe	Altezza vetro fisso laterale Side fixed glass height Seitenteil (seitlich) Höhe

BX-6000 SET 4 DX / BX-6000 SET 4 SX

MY METALGLAS

L = 1500mm / L = 3000mm

DOCCIA CON SPALLA IN VETRO / CORNER SHOWER WITH 2 FIXED PANELS
ECKDUSCHE MIT 2 FESTSTEHENDEN GLASTAFELN

e▶ B.04

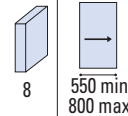

Fin. / Fin. / Oberf.

CR	NO
Cromo lucido	Nero opaco
Polished chrome	Matt black
Chrom glänzend	Matt schwarz

COMPONENTI / COMPONENTS / EINZELTEILE

- BX-6000-C30 (1x)
- BX-6000-C10 (2x)
- BX-6000-C90 (1x)
BX-6000-C81 (1x)
- BX-6000-C70-2 (1x)
- BX-6000-C70-1 (1x)
- OPTIONAL
B-136/BX-PF-01 (2x)
- OPTIONAL

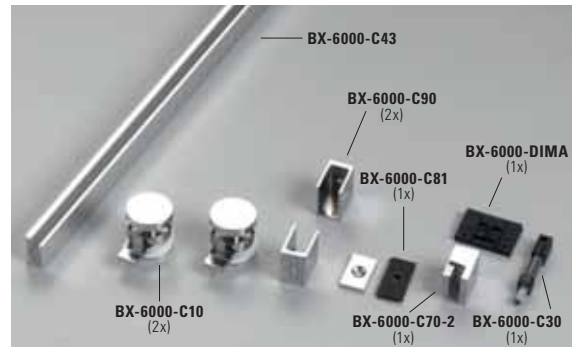
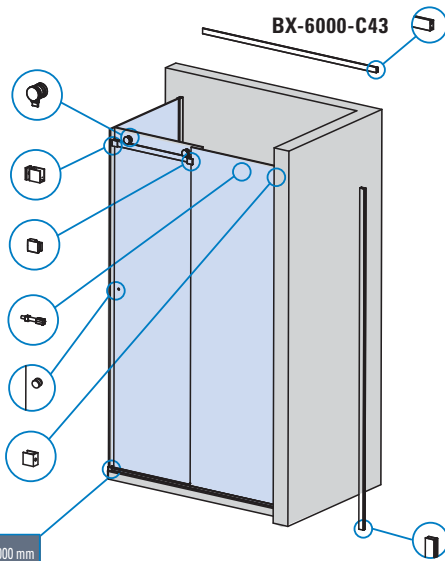

CARATTERISTICHE COMPONENTI / FEATURES COMPONENTS / EIGENSCHAFTEN EINZELTEILE ▶ 22



- Obbligatorio fissaggio a parete tramite profili a "U" o morsetti (non inclusi)
- Necessary wall-mounting with "U" profiles or clamps (not included)
- Verbindliche Befestigung an der Wand mit „U“-Profilen oder Wandhaltern (nicht inbegriffen)

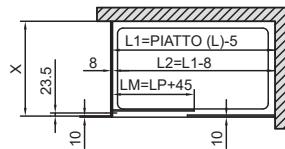
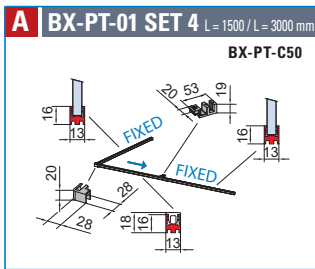

PROFILI A TERRA / FLOOR PROFILES / BODENPROFILE ▶ 88

xme556g

BX-6020 SOFT-CLOSE SET 4



MY METALGLAS

L = 1500mm / L = 3000mm

DOCCIA CON SPALLA IN VETRO / CORNER SHOWER WITH 2 FIXED PANELS
ECKDUSCHE MIT 2 FESTSTEHENDEN GLASTAFELN

e▶ B.10

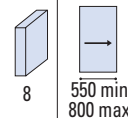

Fin. / Fin. / Oberf.

CR	NO
Cromo lucido	Nero opaco
Polished chrome	Matt black
Chrom glänzend	Matt schwarz

COMPONENTI / COMPONENTS / EINZELTEILE

- BX-6000-SOFT-CLOSE (1x)
- BX-6000-C11 (1x)
BX-6000-C12 (1x)
- BX-6000-C90 (1x)
BX-6000-C81 (1x)
- BX-6000-C90 (1x)
- BX-6000-C70-1 (1x)
- OPTIONAL
B-136/BX-PF-01 (2x)
- OPTIONAL

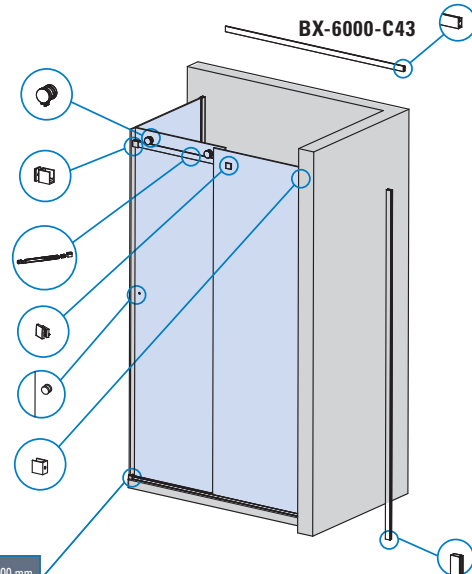

CARATTERISTICHE COMPONENTI / FEATURES COMPONENTS / EIGENSCHAFTEN EINZELTEILE ▶ 22

- Obbligatorio fissaggio a parete tramite profili a "U" o morsetti (non inclusi)
- Necessary wall-mounting with "U" profiles or clamps (not included)
- Verbindliche Befestigung an der Wand mit „U“-Profilen oder Wandhaltern (nicht inbegriffen)

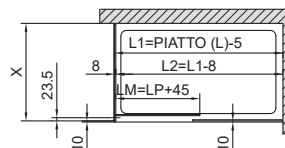
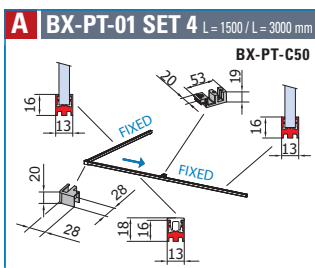

PROFILI A TERRA / FLOOR PROFILES / BODENPROFILE ▶ 88

xme556h

LAVORAZIONE VETRO / GLASS PREPARATION / GLASBEARBEITUNG

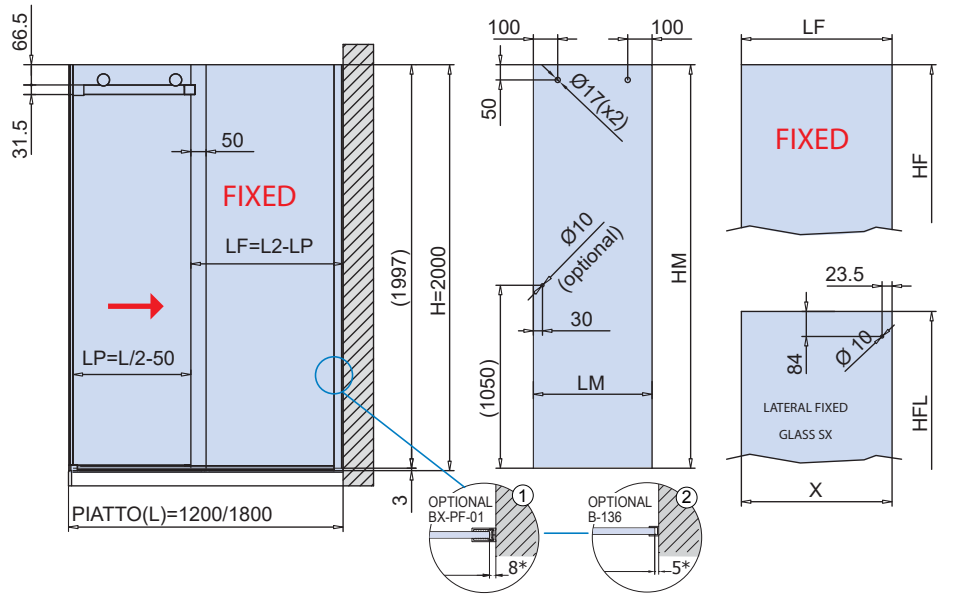

CALCOLO VETRO / CALCULATION GLASS / GLASBERECHNUNG

PIATTO - SHOWER TRAY - DUSCHTASSE (L) = 1200 - 1800 mm

L1=PIATTO (L) - 5

L2=L1 - 8

Passaggio (LP) = L2 / 2 - 50

Vetro Mobile Larghezza (LM) = LP + 45

Vetro Fisso Larghezza (LF) = L2 - LP - * ① / * ② (aria variabile / clearance / Spaltmaß)

X = CALCOLARE / CALCULATE / BERECHNEN

Vetro Mobile Altezza (HM) = H - 8 = 1992mm

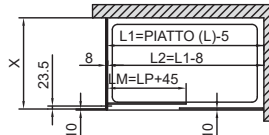

PROFILI A TERRA / FLOOR PROFILES / BODENPROFILE ▶ 88

A BX-PT-01 STANDARD HF = H - 3 = 1997 mm HFL = H - 3

xme556g

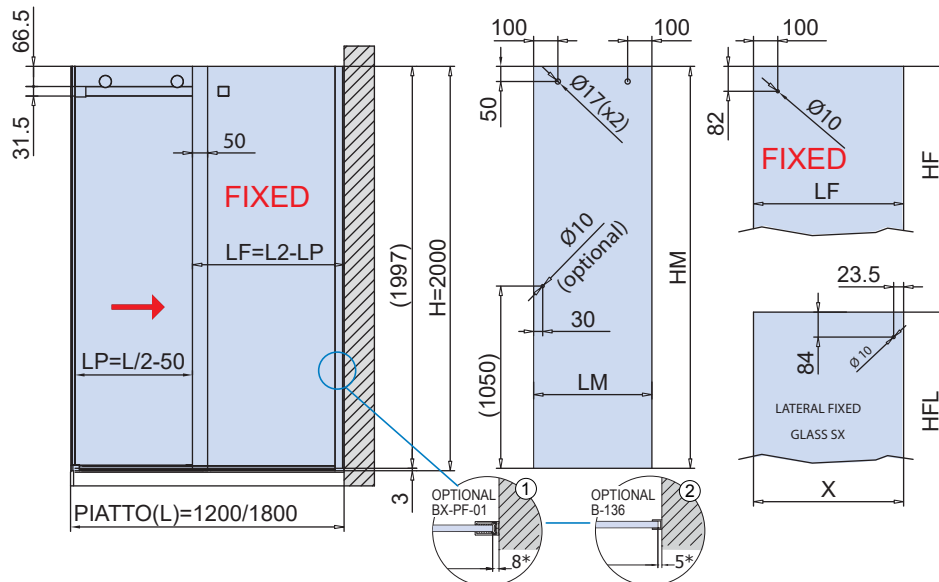

CALCOLO VETRO / CALCULATION GLASS / GLASBERECHNUNG

PIATTO - SHOWER TRAY - DUSCHTASSE (L) = 1200 - 1800 mm

L1=PIATTO (L)-5

L2=L1 - 8

Passaggio (LP) = L2 / 2 - 50

Vetro Mobile Larghezza (LM) = LP + 45

Vetro Fisso Larghezza (LF) = L2 - LP - * ① / * ② (aria variabile / clearance / Spaltmaß)

X = CALCOLARE / CALCULATE / BERECHNEN

Vetro Mobile Altezza (HM) = H - 8 = 1992mm

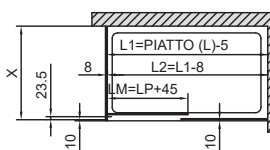

PROFILI A TERRA / FLOOR PROFILES / BODENPROFILE ▶ 88

A BX-PT-01 STANDARD HF = H - 3 = 1997 mm HFL = H - 3

xme556h

SET 4

DA TAGLIARE / ADJUST THE LENGTH /
BELIEBIG KÜRZBAR ✂

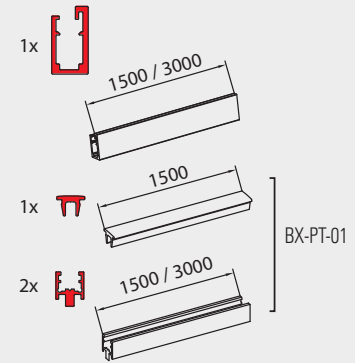

- Regolazione ± 2 mm.
- Adjustment ± 2 mm.
- Verstellung ± 2 mm.

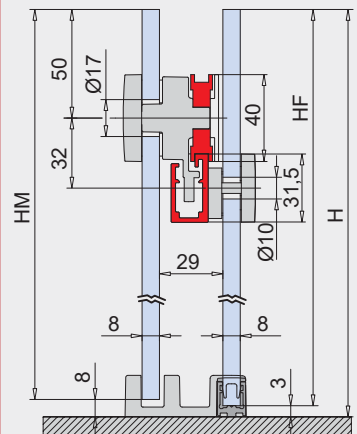

HM = H - 8
HF = H - 3
solo per / only for / nur für
BX-PT-01

OPTIONAL



L	LP	LM	LF	HM	HF	H	HFL
Piatto	Passaggio luce	Larghezza vetro mobile	Larghezza vetro fisso	Altezza vetro mobile	Altezza vetro fisso	Altezza doccia	Altezza vetro fisso laterale
Shower tray	Clear opening width	Sliding glass width	Side fixed glass width	Sliding glass height	Side fixed glass height	Shower height	Side fixed glass height
Duschtasse	Lichte Durchgangsbreite	Schiebeflügel Breite	Seitenteil Breite	Schiebeflügel Höhe	Seitenteil Höhe	Duschkabinen Höhe	Seitenteil (seitlich) Höhe

BX-6000 / BX-6020 SOFT-CLOSE

COMPONENTI / COMPONENTS / EINZELTEILE

SCORREVOLI



BX-6000-C43/ BX-6000-C40

- Binario
- Track profile
- Laufschiene

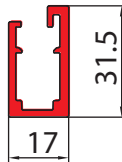

Cod.	Fin. / Fin. / Oberf.
BX-6000-C43-1500 mm	CR / NO
BX-6000-C43-3000 mm	CR / NO
BX-6000-C40-1000 x 1000 mm (2 pcs)	CR / NO

[e▶ B.13](#)

xme556i



BX-6000-C10

- Ruota con antigancio per set **senza** soft-close
- Roller with antijump for sets **without** soft-close
- Laufrolle und Aushebeschutz für sets **ohne** soft-close

CR - NO

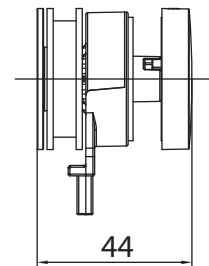
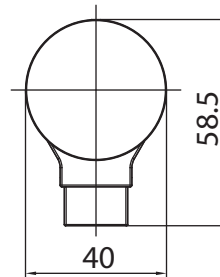

[e▶ B.14](#)

xme556i



BX-6000-C11

- Ruota con attivatore per versione soft-close
- Roller with antijump and soft-close activator
- Laufrolle mit Aushebeschutz und soft-close Mitnehmer

CR - NO

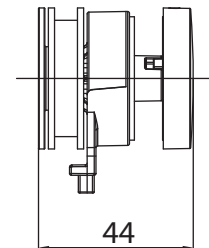
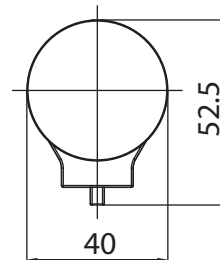

[e▶ B.15](#)

xme556i



BX-6000-C12

- Ruota con antigancio per versioni soft-close
- Roller with antijump for soft-close sets
- Laufrolle mit Aushebeschutz für soft-close sets

CR - NO

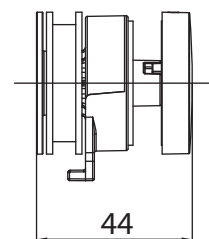
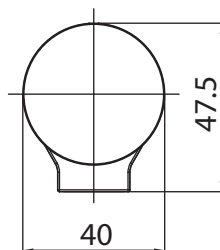

[e▶ B.16](#)

xme556i

BX-6000-C70-2 DX (destro - right - rechts)
BX-6000-C70-2 SX (sinistro - left - links)

- Morsetto vetro fisso per tutti i set versione senza soft-close
- Fixed glass clamp for all sets without soft-close
- Klemme für Seitenteil für alle sets ohne soft-close

e▶ B.17
e▶ B.18

CR - NO

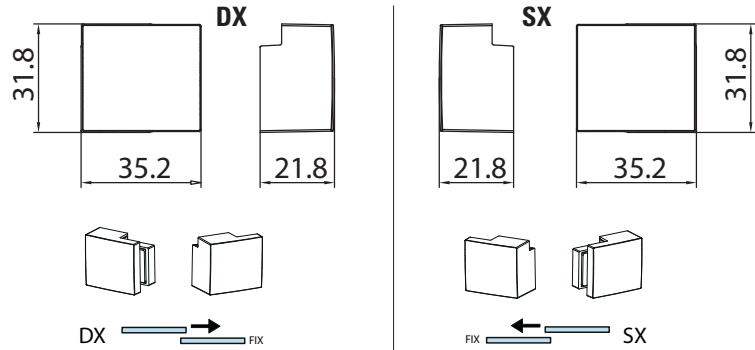

xme556i

BX-6000-C70-1

- Morsetto vetro fisso per tutti i set versione con soft-close e per set 3 senza soft-close
- Fixed glass clamp for all sets with soft-close and for set 3 without soft-close
- Klemme für Seitenteil für alle sets mit soft-close und für set 3 ohne soft-close

e▶ B.19

CR - NO

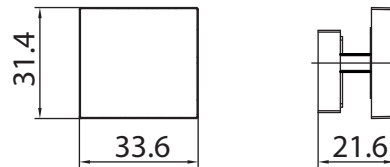

xme556i

BX-6000-C90 DX

- Attacco a parete destro per binario
- Right wall connector for track profile
- Wandhalter rechts für Laufschiene

e▶ B.20

CR - NO

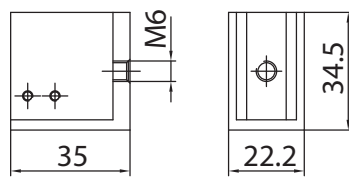

xme556i

BX-6000-C90 SX

- Attacco a parete sinistro per binario
- Left wall connector for track profile
- Wandhalter links für Laufschiene

e▶ B.21

CR - NO

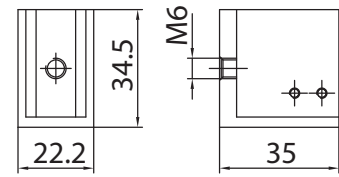

xme556i

BX-6000-C81

- Piastrina attacco a vetro per BX-6000-C90
- Plate glass connector for BX-6000-C90
- Platte Glashalter für BX-6000-C90

e▶ B.22

CR - NO

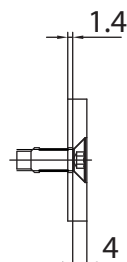

xme556i

BX-6000-C30

- Stopper

e▶ B.24

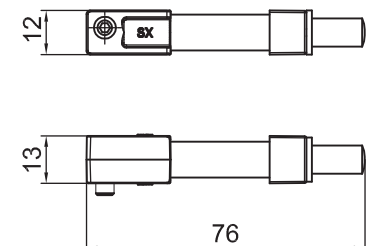

xme556i

BX-6000 / BX-6020 SOFT-CLOSE

COMPONENTI / COMPONENTS / EINZELTEILE

SCORREVOLI



BX-6000-C20

- Connettore ad angolo per binari set 1
- Corner connector for track profiles set 1
- Winkelverbinder Laufschiene set 1

CR - NO

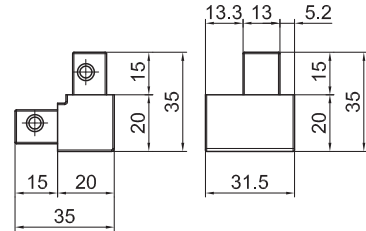

xme556l



BX-6000-DIMA

- Dima per foratura per morsetto vetro fisso
- Template for drilling the track profile with the clamp
- Schablone für das Bohren der Laufschiene mit der Klemme

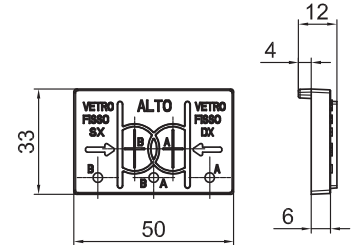

xme556l

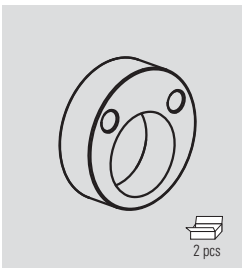

BX-6000 ECCENTR

- Boccia eccentrica optional per regolazione vetro $\pm 2,5$ mm. Attenzione per foro vetro anta mobile da 23 mm
- Eccentric bushing for glass adjustment $\pm 2,5$ mm. Note well: glass hole 23 mm for sliding panel
- Exzentrisch Buchse für Glas Verstellung $\pm 2,5$ mm. Achtung: Glasbohrung 23 mm für Schiebeflügel

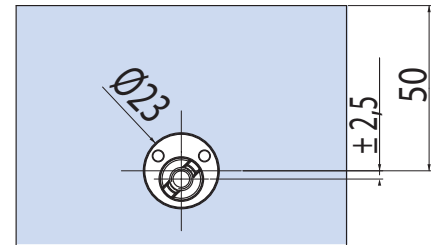
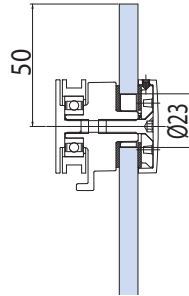
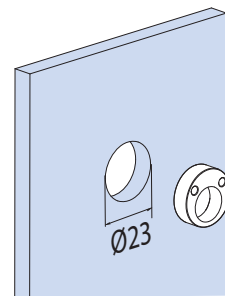

e▶ B.27.1

C-330-U



BX-6000-SOFT-CLOSE

- Soft Close

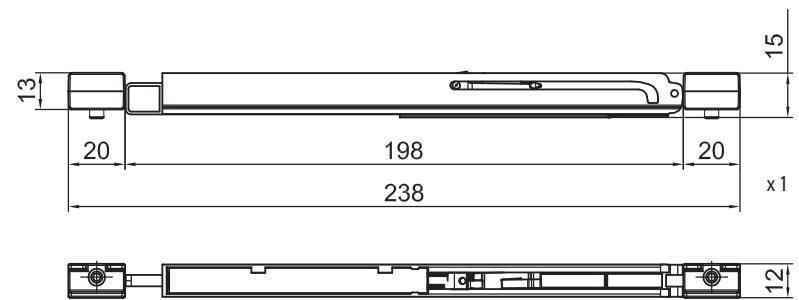

xme556l



BX-PT-C58

- Profilo a terra
- Floor profile
- Bodenprofil

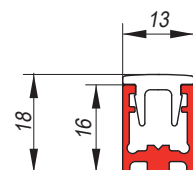

Cod.	Fin./Fin./Fin.
BX-PT-C58-1500 mm	CR / NO
BX-PT-C58-3000 mm	CR / NO

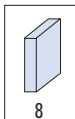

e▶ B.101



BX-PT-C56

- Coperchio per profilo a terra per tratto entrata doccia
- Cover profile for floor profile, shower entry
- Profilabdeckung Bodenprofil Duscheinstieg

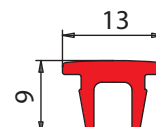

Cod.	Fin./Fin./Fin.
BX-PT-C56-1500 mm	CR / NO
BX-PT-C56-3000 mm	CR / NO

e▶ B.102





SCORREVOLI

LINEA BX-4000

IL BOX DOCCIA MINIMAL E SEMPLICE DA MONTARE

BX-4000 LINEA è il sistema scorrevole per box doccia disponibile nelle versioni ad angolo, lineare e a nicchia. Eleganza e perfezione estetica e funzionale caratterizzano uno tra i brevetti di maggior successo dell'azienda Metalglas.

DESIGN E INNOVAZIONE SENZA PRECEDENTI.

MINIMAL AND EASY TO ASSEMBLE

A sliding system for shower enclosure, available for corner, niche or U-shower installations. Elegance, functionality and essentiality for an exclusive patented concept.

UNIQUE DESIGN AND INNOVATION

EINFACH UND LEICHT ZU MONTIEREN

Schiebetürsysteme für Duschkabinen, lieferbar für Eck- Nische- und U-Dusche. Funktionalität und minimale Eleganz für ein exklusives und patentiertes Konzept.

EINZIGARTIGES DESIGN UND INNOVATION.



NEW

PLUS

- CONCEPT E BREVETTO ESCLUSIVO
- BINARIO ALTO SOLO 26 MM
- ELEGANTE FUNZIONALE ESSENZIALE
- FACILE DA MONTARE
- POSSIBILITÀ DI SGANCIARE LA GUIDA INFERIORE PER UNA PERFETTA PULIZIA
- PINZE REGOLABILI IN ALTEZZA +/- 2,5MM

- Exclusive patented concept
- Rail only 26 mm high
- Elegant, functional, essential
- Easy to assemble
- Quick release door function for easy cleaning
- +/- 2,5 mm clamps adjustment

- Exclusives und patentiertes Konzept
- Schienenhöhe nur 26 mm
- Qualität, Optik, Funktionalität
- Einfache Montage
- Die auslösbare Bodenführung erleichtert das Reinigen
- Höhenverstellbare Laufwagen +/- 2,5 mm

BX-4000 LINEA 30

- Sistema scorrevole per box doccia, altezza binario solo 26 mm, disponibile per versioni in angolo, lineare e in nicchia. Materiale: alluminio
Finitura: cromo lucido e nero opaco.
- Sliding system for shower box, track profile's height only 26 mm, available for corners, single doors or for niche installations. Material: aluminium
Finish: polished chrome and matt black.
- Schiebetüresystem für Duschkabinen, Laufschiene Höhe nur 26 mm, lieferbar für Eck-, Linear und Nischenduschen. Material: Aluminium.
Oberfläche: chrom poliert und matt schwarz.





SCORREVOLI

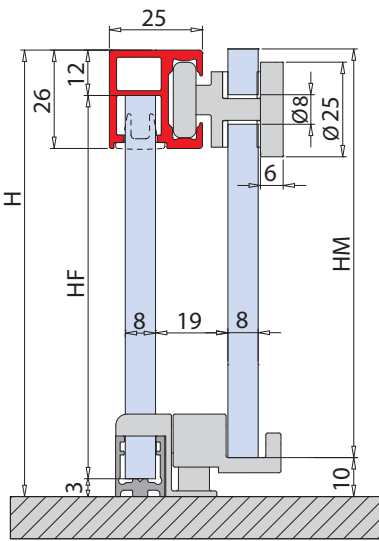

SET 1 [e▶ B.28](#)

SET 2 [e▶ B.29](#)

SET 3 [e▶ B.30](#)

SET 4 [e▶ B.31](#)

SET 5 [e▶ B.32](#)

SET 6 [e▶ B.33](#)

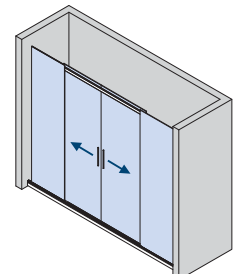
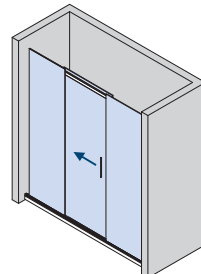
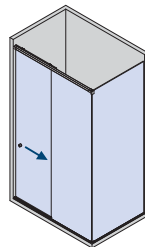
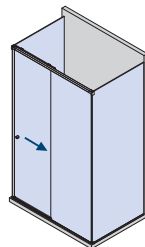
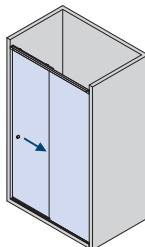
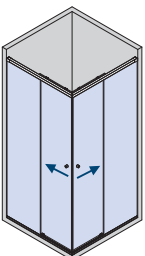

BX-4000 LINEA 30 SET 1

L = 1000 x 1000 mm

DOCCIA IN ANGOLO / CORNER SHOWER / ECKDUSCHE

MY METALGLAS

e▶ B.28

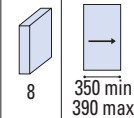

Fin. / Fin. / Oberf.

CR	NO
Cromo lucido	Nero opaco
Polished chrome	Matt black
Chrom glänzend	Matt schwarz

COMPONENTI / COMPONENTS / EINZELTEILE

BX-4000-C30 (2x)

BX-4000-C10 (4x)

BX-4000-C90 (2x)

BX-4000-C20 (1x)

OPTIONAL

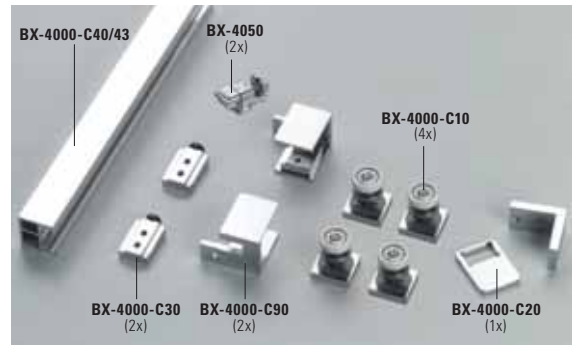
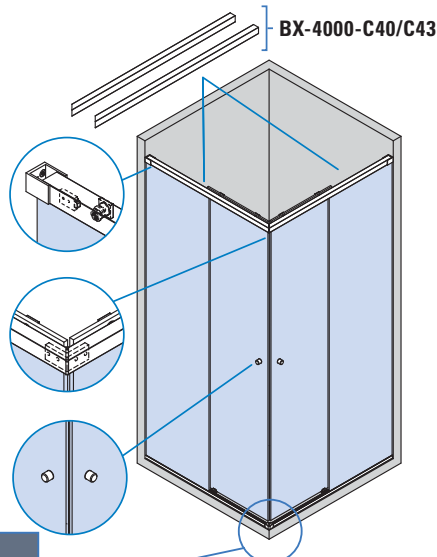

CARATTERISTICHE COMPONENTI /
FEATURES COMPONENTS /
EIGENSCHAFTEN EINZELTEILE ▶ 34

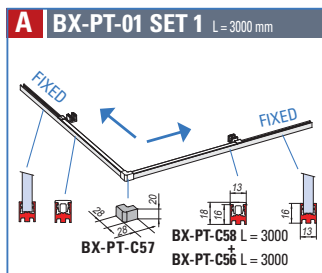

PROFILI A TERRA / FLOOR PROFILES / BODENPROFILE ▶ 88

xme512a

BX-4000 LINEA 30 SET 2

L = 1500 mm / L = 3000 mm

DOCCIA IN NICCHIA / NICHE SHOWER / NISCHENDUSCHE

MY METALGLAS

e▶ B.29

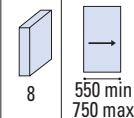

Fin. / Fin. / Oberf.

CR	NO
Cromo lucido	Nero opaco
Polished chrome	Matt black
Chrom glänzend	Matt schwarz

COMPONENTI / COMPONENTS / EINZELTEILE

BX-4000-C30 (1x)

BX-4000-C10 (2x)

BX-4000-C90 (2x)

OPTIONAL

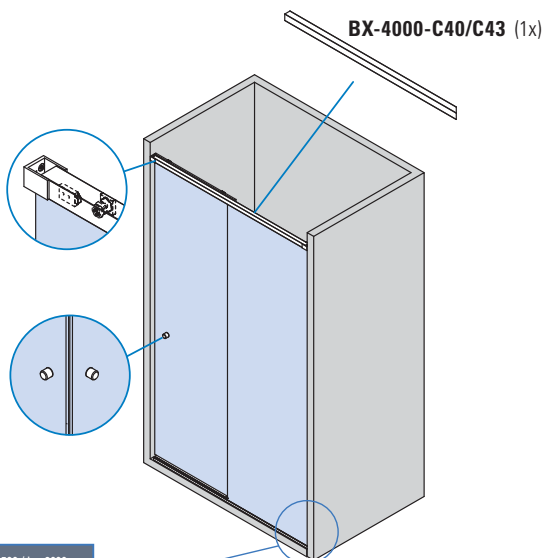

CARATTERISTICHE COMPONENTI /
FEATURES COMPONENTS /
EIGENSCHAFTEN EINZELTEILE ▶ 34

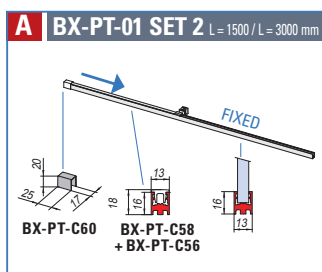

PROFILI A TERRA / FLOOR PROFILES / BODENPROFILE ▶ 88

xme512a

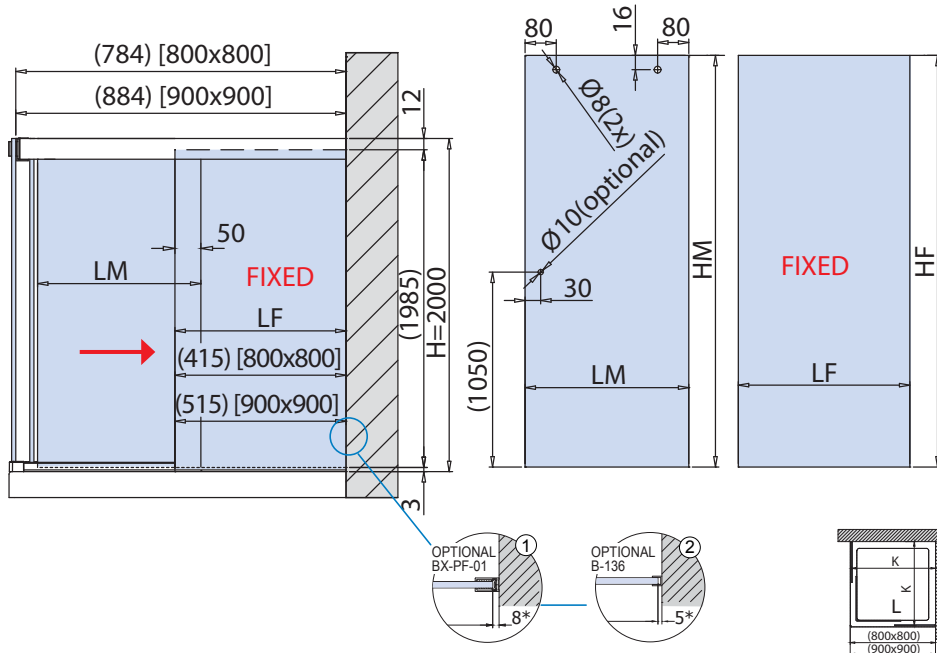
LAVORAZIONE VETRO / GLASS PREPARATION / GLASBEARBEITUNG

CALCOLO VETRO / CALCULATION GLASS / GLASBERECHNUNG

L = 800 x 800 mm (900 x 900) mm

LM = L / 2

LF = [(L / 2)] - (aria variabile / clearance / Spaltmaß)

HM = H - 10 = 1990 mm

PROFILI A TERRA / FLOOR PROFILES / BODENPROFILE ▶ 88

A BX-PT-01 STANDARD HF = H - 15 = 1985 mm

xme512b

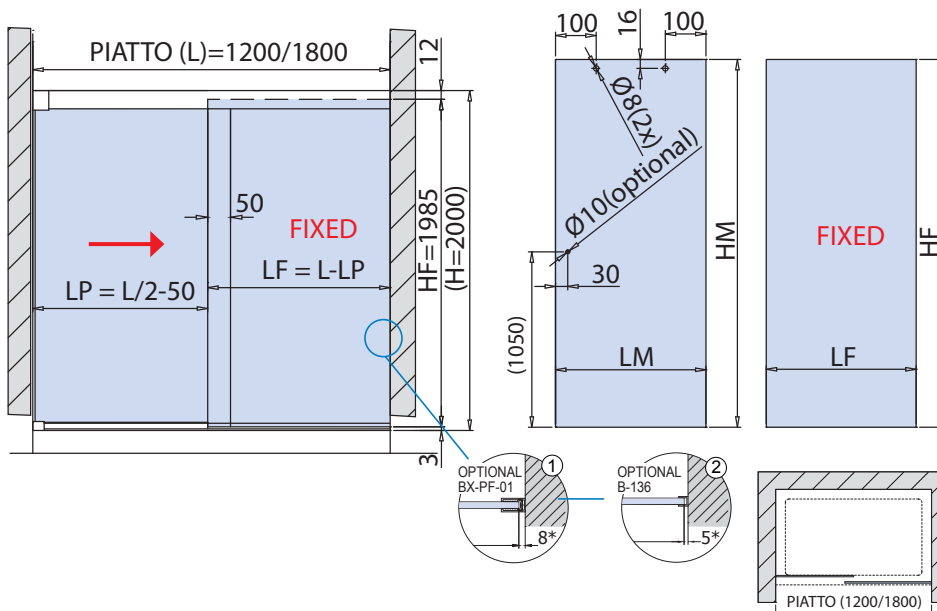
CALCOLO VETRO / CALCULATION GLASS / GLASBERECHNUNG

L = 1200 - 1800 mm

LP = L / 2 - 50

LM = LP + 45

LF = L - LP - (aria variabile / clearance / Spaltmaß)

HM = H - 10 = 1990 mm

PROFILI A TERRA / FLOOR PROFILES / BODENPROFILE ▶ 88

A BX-PT-01 STANDARD HF = H - 15 = 1985 mm

xme512b

SET 1 / SET 2

DA TAGLIARE / ADJUST THE LENGTH / BELIEBIG KÜRZBAR ✂

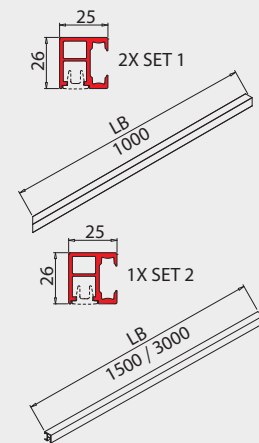

- Regolazione ruota ± 2,5 mm.
- Adjustment ± 2,5 mm.
- Verstellung ± 2,5 mm.

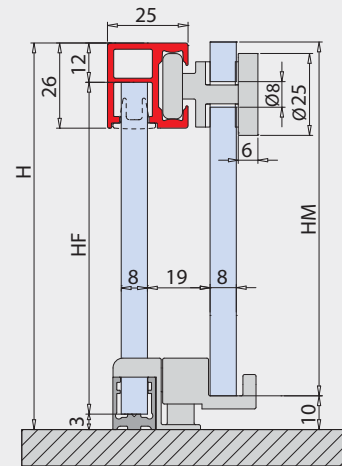

HM = H - 10
HF = H - 15
solo per / only for / nur für
A BX-PT-01

OPTIONAL

L Piatto Shower tray Duschtaße	LP Passaggio luce Clear opening width Lichte Durchgangsbreite	LM Larghezza vetro mobile Sliding glass width Schiebeflügel Breite	LF Larghezza vetro fisso Side fixed glass width Seitenteil Breite	HM Altezza vetro mobile Sliding glass height Schiebeflügel Höhe	HF Altezza vetro fisso Side fixed glass height Seitenteil Höhe	H Altezza doccia Shower height Duschcabine Höhe
--	---	--	---	---	--	---

SCORREVOLI

BX-4000 LINEA 30 SET 3

L = 1500 mm / L = 3000 mm

DOCCIA A U / U SHOWER / U DUSCHE

MY METALGLAS

e▶ B.30

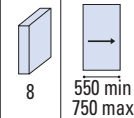

Fin. / Fin. / Oberf.

CR	NO
Cromo lucido	Nero opaco
Polished chrome	Matt black
Chrom glänzend	Matt schwarz

COMPONENTI / COMPONENTS / EINZELTEILE

BX-4000-C30 (1x)

BX-4000-C10 (2x)

BX-4000-C90 (2x)

BX-4000-C81 (2x)

OPTIONAL

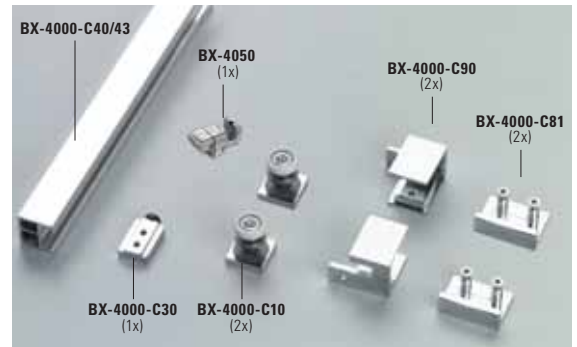
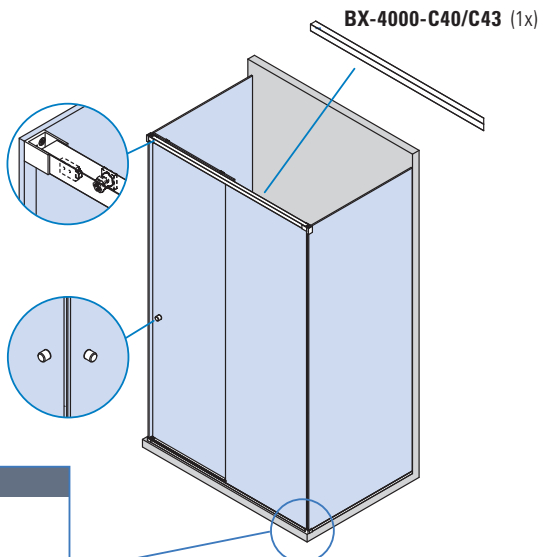

CARATTERISTICHE COMPONENTI /
FEATURES COMPONENTS /
EIGENSCHAFTEN EINZELTEILE ▶ 34

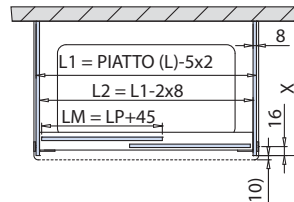
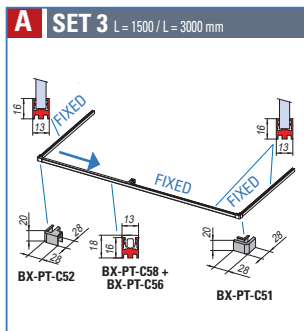

PROFILI A TERRA / FLOOR PROFILES / BODENPROFILE ▶ 88

xme512a

BX-4000 LINEA 30 SET 4

L = 1500 mm / L = 3000 mm

DOCCIA CON SPALLA IN VETRO / CORNER SHOWER WITH 2 FIXED PANEL
ECKDUSCHE MIT 2 FESTSTEHENDEN GLASTAFELN

MY METALGLAS

e▶ B.31

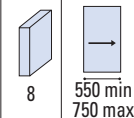

Fin. / Fin. / Oberf.

CR	NO
Cromo lucido	Nero opaco
Polished chrome	Matt black
Chrom glänzend	Matt schwarz

COMPONENTI / COMPONENTS / EINZELTEILE

BX-4000-C30 (1x)

BX-4000-C10 (1x)

BX-4000-C90 SX (1x)

BX-4000-C90 DX (1x)

BX-4000-C81 (1x)

OPTIONAL

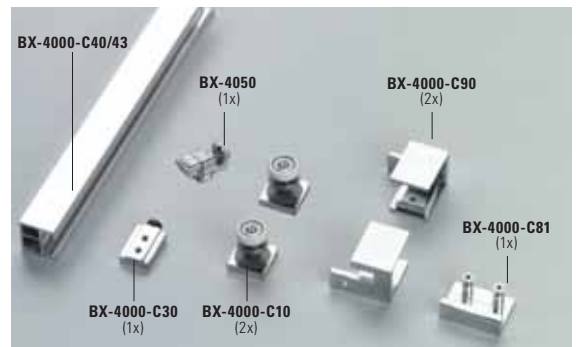
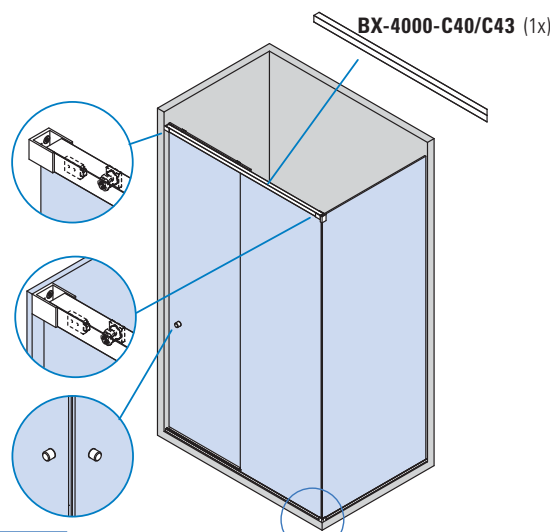

CARATTERISTICHE COMPONENTI /
FEATURES COMPONENTS /
EIGENSCHAFTEN EINZELTEILE ▶ 34

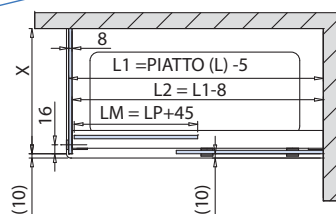
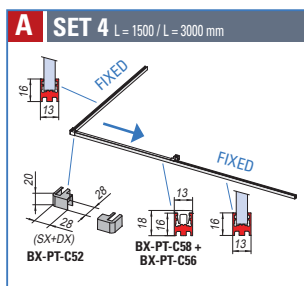

PROFILI A TERRA / FLOOR PROFILES / BODENPROFILE ▶ 88

xme512a

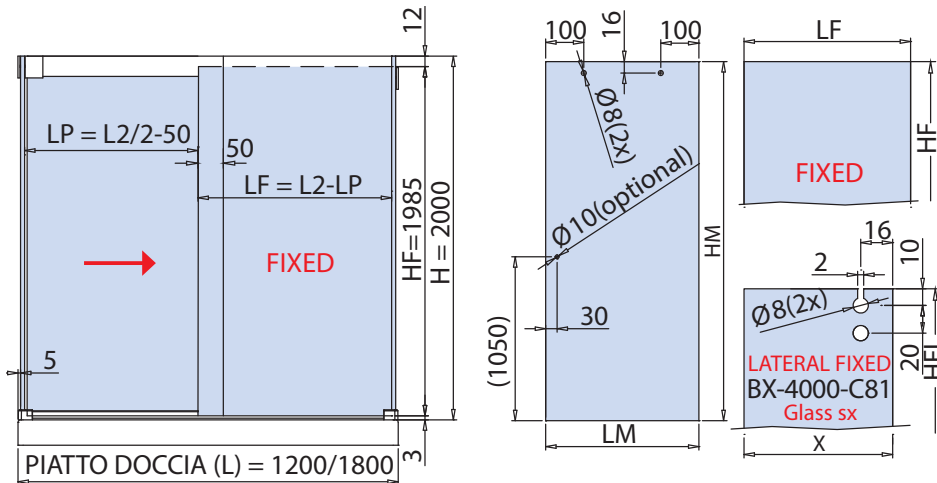
LAVORAZIONE VETRO / GLASS PREPARATION / GLASBEARBEITUNG

CALCOLO VETRO / CALCULATION GLASS / GLASBERECHNUNG

L = 1200 - 1800 mm
 L1 = L - 5 x 2
 L2 = L1 - 2 x 8
 LP = L2 / 2 - 50
 LM = LP + 45
 LF = L2 - LP
 X = calcolare / calculate / berechnen
 HM = H - 10 = 1990 mm

PROFILI A TERRA / FLOOR PROFILES / BODENPROFILE ▶ 88

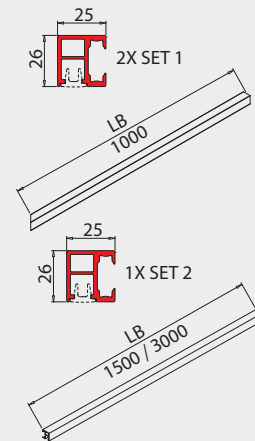
A BX-PT-01 STANDARD HF = H - 15 = 1985 mm HFL = H - 3 xme512b

SET 3 / SET 4
DA TAGLIARE / ADJUST THE LENGTH / BELIEBIG KÜRZBAR ✂

- Regolazione ruota ± 2,5 mm.
- Adjustment ± 2,5 mm.
- Verstellung ± 2,5 mm.

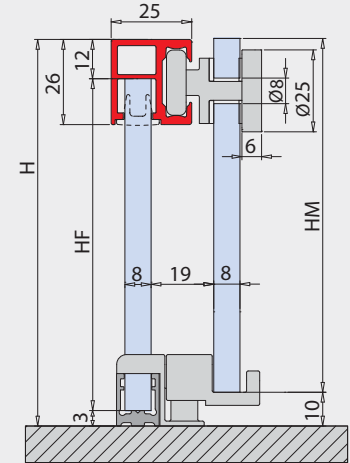

HM = H - 10
 HF = H - 15
 solo per / only for / nur für **BX-PT-01**

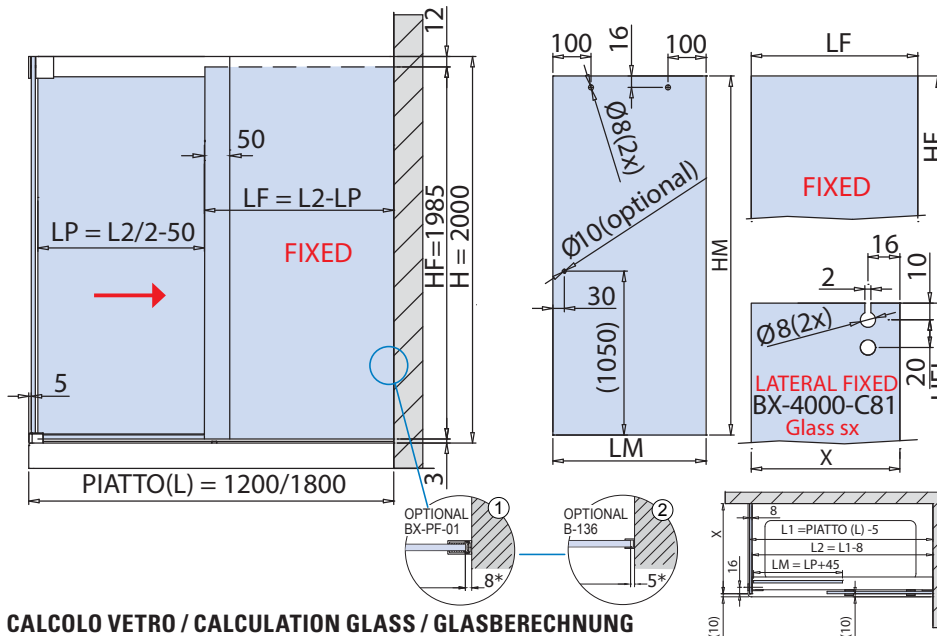
OPTIONAL

CALCOLO VETRO / CALCULATION GLASS / GLASBERECHNUNG

L = 1200 - 1800 mm
 L1 = L - 5
 L2 = L1 - 8
 LP = L2 / 2 - 50
 LM = LP + 45
 LF = L2 - LP - *① / *② (aria variabile / clearance / Spaltmaß)
 X = calcolare / calculate / berechnen
 HM = H - 10 = 1990 mm

PROFILI A TERRA / FLOOR PROFILES / BODENPROFILE ▶ 88

A BX-PT-01 STANDARD HF = H - 15 = 1985 mm HFL = H - 3 xme512b

L	LP	LM	LF	HM	HF	H	HFL
Piatto	Passaggio luce	Larghezza vetro mobile	Larghezza vetro fisso	Altezza vetro mobile	Altezza vetro fisso	Altezza doccia	Altezza vetro fisso laterale
Shower tray	Clear opening width	Sliding glass width	Side fixed glass width	Sliding glass height	Side fixed glass height	Shower height	Side fixed glass height
Duschtaße	Lichte Durchgangsbreite	Schiebefügel Breite	Seitenteil Breite	Schiebefügel Höhe	Seitenteil Höhe	Duschcabinen Höhe	Seitenteil (seitlich) Höhe

SCORREVOLI

BX-4000 LINEA 30

COMPONENTI / COMPONENTS / EINZELTEILE

SCORREVOLI

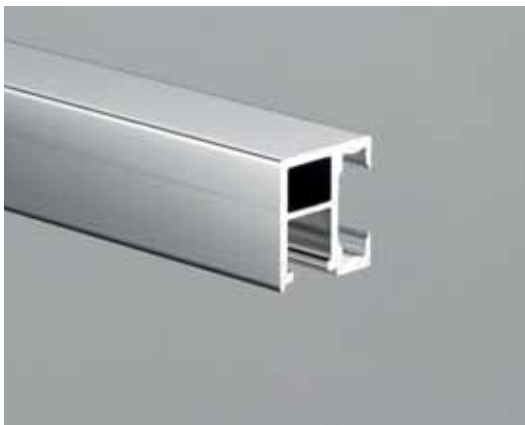

BX-4000-C43/BX-4000-C40

- Binario con veletta BX-4001 inclusa
- Track profile with cover profile BX-4001 included
- Laufschiene mit Sichtschutzprofil BX-4001 enthalten

CR - NO

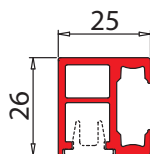

Cod.	Fin. / Fin. / Oberf.
BX-4000-C43-1500 mm	CR / NO
BX-4000-C43-3000 mm	CR / NO
BX-4000-C40-1000 x 1000 mm (2 pcs 45°)	CR / NO

[e▶ B.35](#)

[e▶ B.36](#)

xme216



BX-4000-C10

- Ruota
- Roller
- Laufrolle

CR - NO

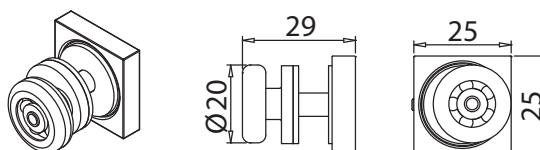

[e▶ B.37](#)

xme512c



BX-4000-C90 DX

- Attacco a parete destro per binario
- Right wall connector for track profile
- Wandhalter rechts für Laufschiene

CR - NO

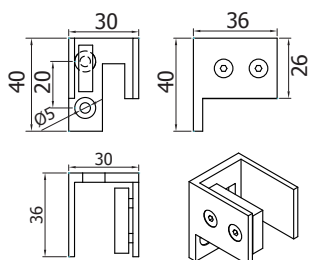

xme512c



BX-4000-C90 SX

- Attacco a parete sinistro per binario
- Left wall connector for track profile
- Wandhalter links für Laufschiene

CR - NO

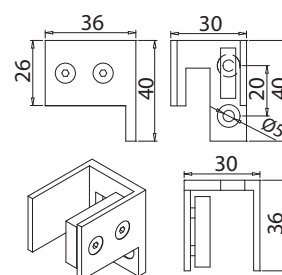

xme512c



BX-4000-C81

BX-4000-C90

- Non incluso
- Not included
- Nicht enthalten

BX-4000-C81

- Piastrina attacco a vetro binario
- Plate glass connector rail
- Platte Glashalter Laufschiene

CR - NO

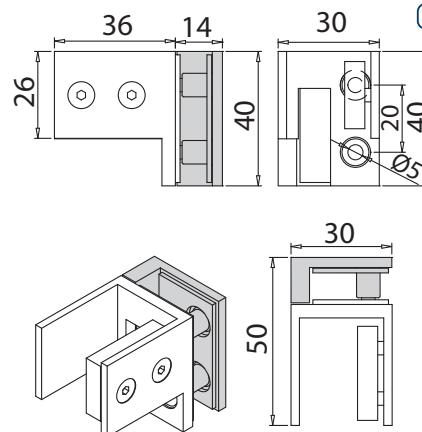

[e▶ B.40](#)

xfb-065

BX-4000-C30

- Stopper
- CR - NO

e▶ B.41

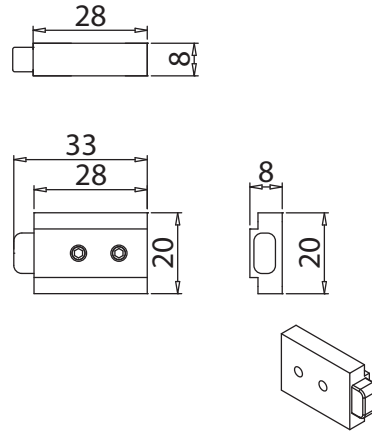

xme512c

BX-4000-C20

- Connettore ad angolo per binario set 1
- Corner connector for track profile set 1
- Winkelverbinder Laufschiene set 1
- CR - NO

e▶ B.42

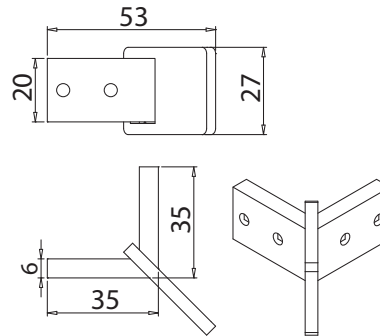

xme512c

BX-4050

- Guida vetro scorrevole BX-4050 per applicazione con profilo a terra BX-PT-C58 con sistema di sgancio della porta per facilitare la pulizia.
- Floor guide sliding panel BX-4050 for installation with floor profile BX-PT-C58 with quick release door function for easy cleaning.
- Schiebetür Bodenführung BX-4050 für Montage mit Bodenprofil BX-PT-C58 mit auslosbarem System um das Reinigen zu erleichtern.
- CR - NO

e▶ B.43

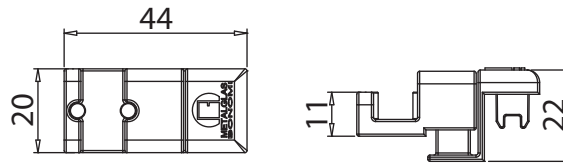

xme512c



BX-PT-C58

- Profilo a terra
- Floor profile
- Bodenprofil

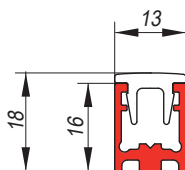
e▶ B.101

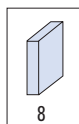

Cod.	Fin./Fin./Fin.
BX-PT-C58-1500 mm	CR / NO
BX-PT-C58-3000 mm	CR / NO

BX-PT-C56

- Coperchio per profilo a terra per tratto entrata doccia
- Cover profile for floor profile, shower entry.
- Profilabdeckung Bodenprofil Duscheinstieg

e▶ B.102

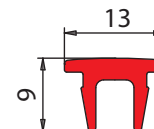

Cod.	Fin./Fin./Fin.
BX-PT-C56-1500 mm	CR / NO
BX-PT-C56-3000 mm	CR / NO



BX-3100 COMPACT

LA DOCCIA INVISIBILE

BX-3100 è il sistema per box doccia semplice e veloce.
 Semplice e veloce nel montaggio grazie all'assenza di lavorazioni nel vetro.
 Semplice e veloce da pulire con la possibilità di sgancio nella guida inferiore.

FUNZIONALITÀ PERFETTA E GRANDE IMPATTO ESTETICO.

- THE INVISIBLE SHOWER ENCLOSURE
- BX-3100 is a sliding shower enclosure without glass preparation and with optional soft-close closing system, easy and quickly to install. Release door function for easy cleaning.
- FUNCTIONALITY MEETS DESIGN.
- Unsichtbare Duschkabine
- Bx-3100, die Duschkabine ohne Glasbearbeitung, mit optionalem Dämpfung System, einfache und schnelle Montage. Die auslösbare Bodenführung erleichtert das Reinigen.
- Funktionalität trifft auf Design.



SCORREVOLI



NEW

PLUS

- MINIMAL E SEMPLICE DA MONTARE
- PINZE REGOLABILI IN ALTEZZA +/- 2,5 MM
- VETRO FISSO INGLOBATO NEL BINARIO
- POSSIBILITÀ DI SOFT-CLOSE SIA IN APERTURA CHE IN CHIUSURA
- DISTANZA TRA VETRO FISSO E MOBILE DI 11 MM
- POSSIBILITÀ DI SGANCIARE LA GUIDA INFERIORE PER UNA PERFETTA PULIZIA

- Minimal and easy to assemble
- Adjustable clamp height +/- 2,5 mm
- Fixed glass enclosed in the rail
- Possible soft-close in both opening and closure
- Only 11mm gap between panels
- Quick release door function for easy cleaning

- Einfach und leicht zu montieren
- Höhenverstellbare Befestigungsklammern +/- 2,5 mm
- Festes Glas in die Schiene eingebaut
- Soft-close beidseitig beim öffnen und schließen möglich
- Nur 11 mm Abstand zwischen den Glasscheiben
- Die auslösbare Bodenführung erleichtert das Reinigen

**BX-3100 CON VELETTA (OPTIONAL SOFT-CLOSE)
WITH COVER / MIT ABDECKUNG**



SCORREVOLI



- Sistema scorrevole per box doccia disponibile per versioni in angolo, lineare e in nicchia. Possibilità di regolazione tramite ruota $\pm 2,5$ mm. Optional soft-close
- Sliding system for shower box, available for corners, single doors or for niche installations. Adjustment of carrying wheels $\pm 2,5$ mm. Optional soft-close
- Schiebetürsystem für Duschkabinen, lieferbar für Eck-, Linear und Nischenduschen. Höheneinstellung der Räder $\pm 2,5$ mm. Optional soft-close



SCORREVOLI

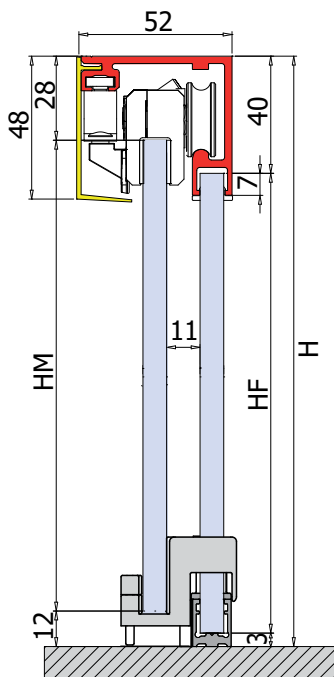

 SET 1 [e▶ B.44](#)

 SET 2 [e▶ B.45](#)

 SET 3 [e▶ B.46](#)

 SET 4 [e▶ B.47](#)

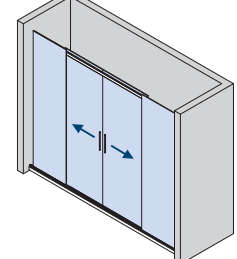
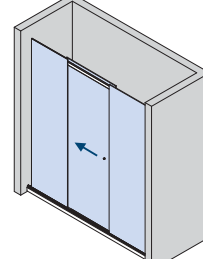
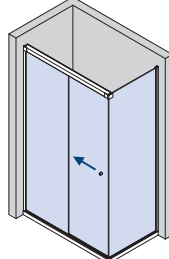
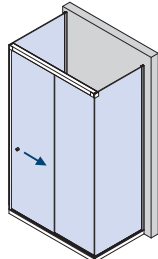
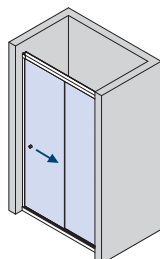
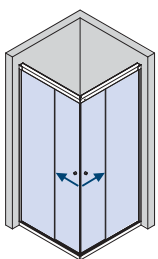
 SET 5 [e▶ B.48](#)

 SET 6 [e▶ B.49](#)

BX-3100 SET 1

L = 1000 x 1000 mm

DOCCIA IN ANGOLO / CORNER SHOWER / ECKDUSCHE

MY METALGLAS

e ▶ B.44

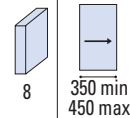

Fin. / Fin. / Oberf.

CR	NO
Cromo lucido	Nero opaco
Polished chrome	Matt black
Chrom glänzend	Matt schwarz

COMPONENTI / COMPONENTS / EINZELTEILE

BX-3100-C90 DX (1x)
BX-3100-C90 SX (1x)

BX-3100-C10 (2x)

BX-3100-C20 (1x)

BX-3106 (2x)
OPTIONAL SOFT-CLOSE



OPTIONAL

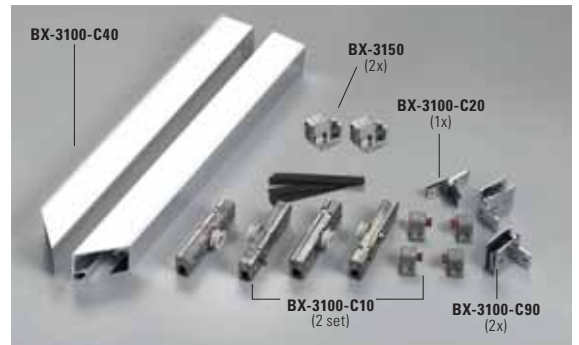
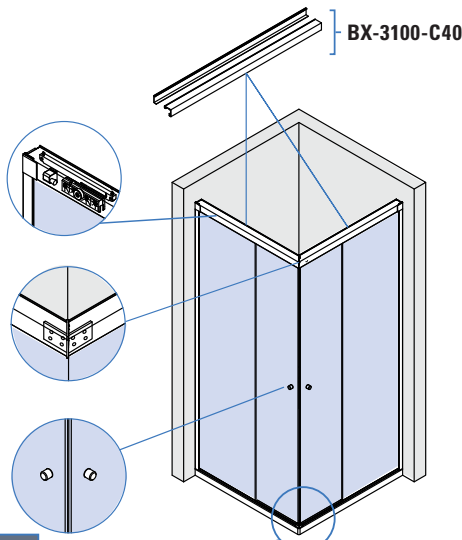

CARATTERISTICHE COMPONENTI /
FEATURES COMPONENTS /
EIGENSCHAFTEN EINZELTEILE ▶ 44

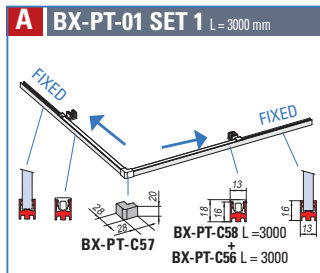

PROFILI A TERRA / FLOOR PROFILES / BODENPROFILE ▶ 88

xme551a

BX-3100 SET 2

L = 1500 mm / L = 3000 mm

DOCCIA IN NICCHIA / NICHE SHOWER / NISCHENDUSCHE

MY METALGLAS

e ▶ B.45

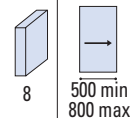

Fin. / Fin. / Oberf.

CR	NO
Cromo lucido	Nero opaco
Polished chrome	Matt black
Chrom glänzend	Matt schwarz

COMPONENTI / COMPONENTS / EINZELTEILE

BX-3100-C90 DX (1x)
BX-3100-C90 SX (1x)

BX-3100-C10 (1x)

BX-3106 (1x)
OPTIONAL SOFT-CLOSE



OPTIONAL

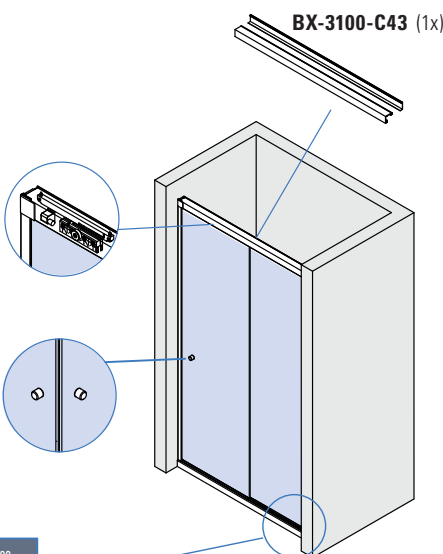

CARATTERISTICHE COMPONENTI /
FEATURES COMPONENTS /
EIGENSCHAFTEN EINZELTEILE ▶ 44

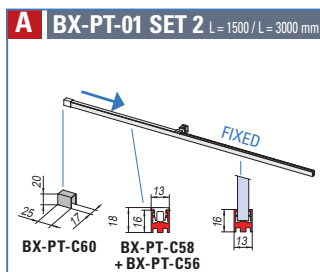

PROFILI A TERRA / FLOOR PROFILES / BODENPROFILE ▶ 88

xme551a

LAVORAZIONE VETRO / GLASS PREPARATION / GLASBEARBEITUNG

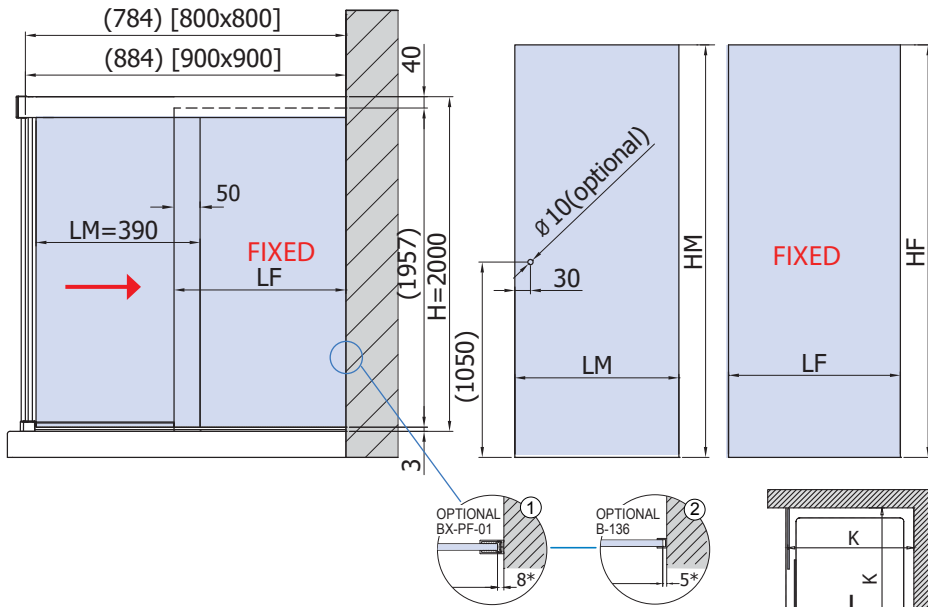

CALCOLO VETRO / CALCULATION GLASS / GLASBERECHNUNG

PIATTO - SHOWER TRAY - DUSCHTASSE (L) = 800 x 800 mm (900 x 900) mm

$$LM = (L+20) / 2$$

$$LF = (L+20) / 2 - * \textcircled{1} / * \textcircled{2} \text{ (aria variabile / clearance / Spaltmaß)}$$

$$HM = H - 40$$

PROFILI A TERRA / FLOOR PROFILES / BODENPROFILE ▶ 88

A BX-PT-01 STANDARD HF = H - 43 = 1957 mm

xme551b

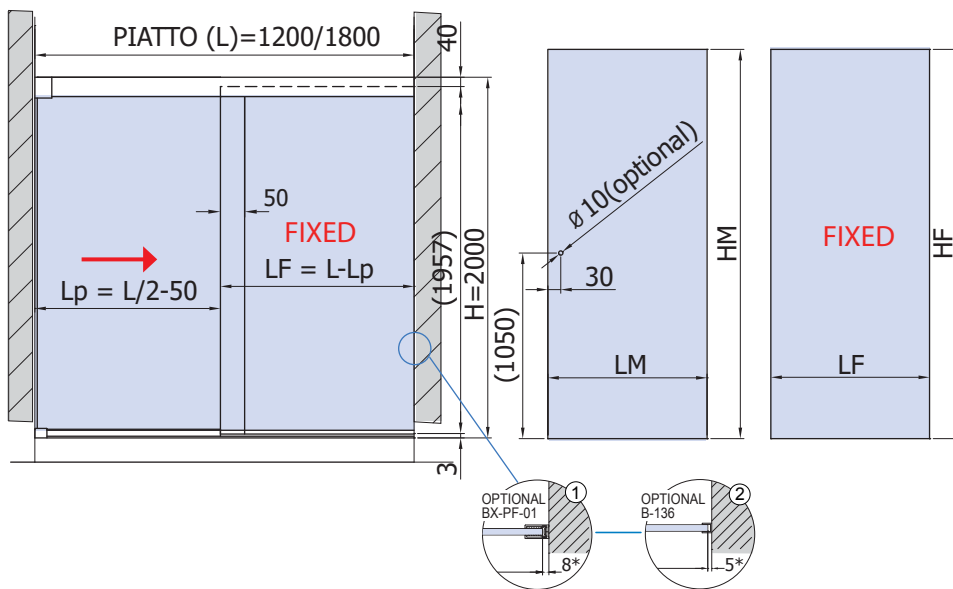

CALCOLO VETRO / CALCULATION GLASS / GLASBERECHNUNG

PIATTO - SHOWER TRAY - DUSCHTASSE (L) = 1200 - 1800 mm

$$LP = L / 2 - 50$$

$$LM = LP + 50$$

$$LF = L - LP - * \textcircled{1} / * \textcircled{2} \text{ (aria variabile / clearance / Spaltmaß)}$$

$$HM = H - 40$$

PROFILI A TERRA / FLOOR PROFILES / BODENPROFILE ▶ 88

A BX-PT-01 STANDARD HF = H - 43 = 1957 mm

xme551b

SET 1 / SET 2

DA TAGLIARE / ADJUST THE LENGTH / BELIEBIG KÜRZBAR ✂

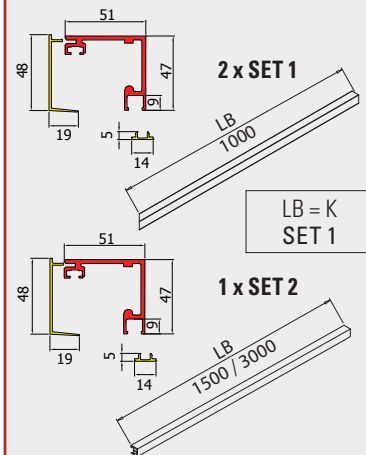

- Regolazione ruota ± 2,5 mm.
- Adjustment ± 2,5 mm.
- Verstellung ± 2,5 mm.

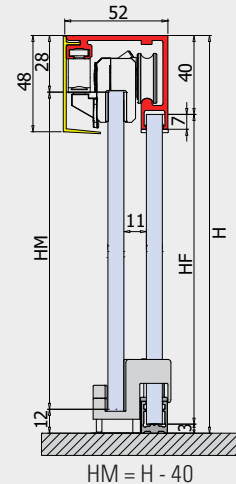

HF = H - 43
solo per / only for / nur für
A BX-PT-01

OPTIONAL



L
Piatto
Shower tray
Duschtaße

LP
Passaggio luce
Clear opening width
Lichte Durchgangsbreite

LM
Larghezza vetro mobile
Sliding glass width
Schiebeflügel Breite

LF
Larghezza vetro fisso
Side fixed glass width
Seitenteil Breite

HM
Altezza vetro mobile
Sliding glass height
Schiebeflügel Höhe

HF
Altezza vetro fisso
Side fixed glass height
Seitenteil Höhe

H
Altezza doccia
Shower height
Duschcabine Höhe

BX-3100 SET 3

L = 1500 mm / L = 3000 mm
DOCCIA A U / U SHOWER / U DUSCHE

MY METALGLAS

e▶ B.46

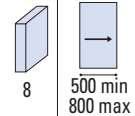

Fin. / Fin. / Oberf.

CR	NO
Cromo lucido	Nero opaco
Polished chrome	Matt black
Chrom glänzend	Matt schwarz

COMPONENTI / COMPONENTS / EINZELTEILE

BX-3100-C90 DX (1x)
BX-3100-C90 SX (1x)

BX-3100-C81 DX (1x)
BX-3100-C81 SX (1x)

BX-3100-C10 (1x)

BX-3106 (1x)
OPTIONAL SOFT-CLOSE



OPTIONAL

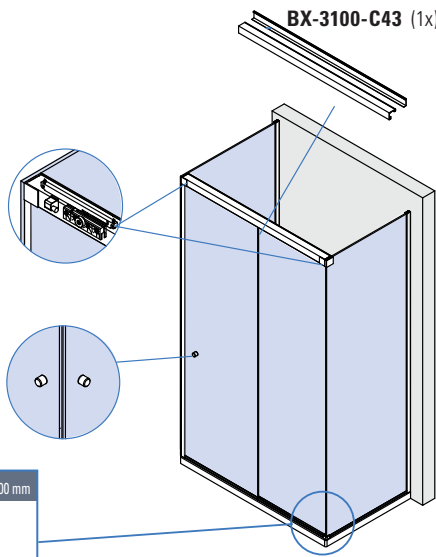

CARATTERISTICHE COMPONENTI /
FEATURES COMPONENTS /
EIGENSCHAFTEN EINZELTEILE ▶ 44

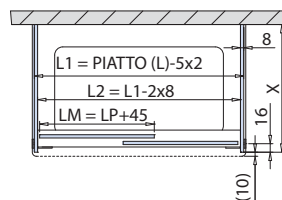
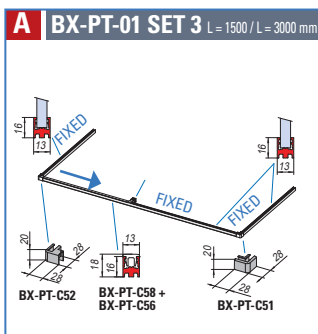

PROFILI A TERRA / FLOOR PROFILES / BODENPROFILE ▶ 88

xme551a

BX-3100 SET 4

L = 1500 mm / L = 3000 mm
DOCCIA CON SPALLA IN VETRO / CORNER SHOWER WITH 2 FIXED PANEL
ECKDUSCHE MIT 2 FESTSTEHENDEN GLASTAFELN

MY METALGLAS

e▶ B.47

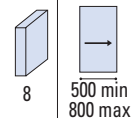

Fin. / Fin. / Oberf.

CR	NO
Cromo lucido	Nero opaco
Polished chrome	Matt black
Chrom glänzend	Matt schwarz

COMPONENTI / COMPONENTS / EINZELTEILE

BX-3100-C90 DX (1x)
BX-3100-C90 SX (1x)

BX-3100-C81 DX (1x)
BX-3100-C81 SX (1x)

BX-3100-C10 (1x)

BX-3106 (1x)
OPTIONAL SOFT-CLOSE



OPTIONAL

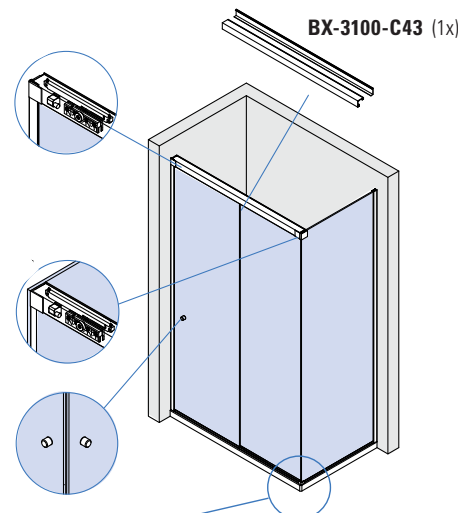

CARATTERISTICHE COMPONENTI /
FEATURES COMPONENTS /
EIGENSCHAFTEN EINZELTEILE ▶ 44

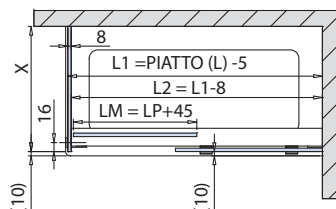
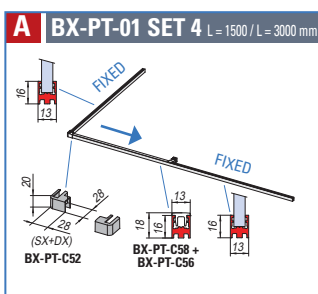

PROFILI A TERRA / FLOOR PROFILES / BODENPROFILE ▶ 88

xme551a

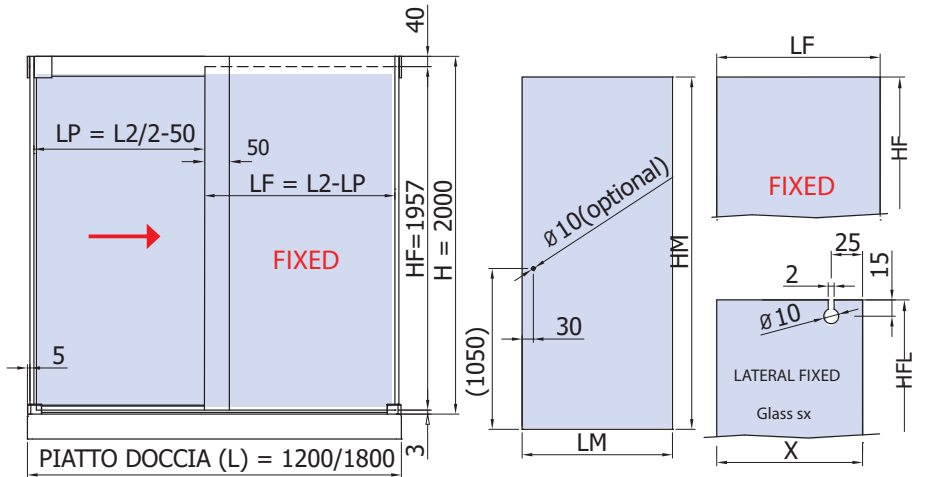
LAVORAZIONE VETRO / GLASS PREPARATION / GLASBEARBEITUNG

CALCOLO VETRO / CALCULATION GLASS / GLASBERECHNUNG

PIATTO - SHOWER TRAY - DUSCHTASSE (L) = 1200 - 1800 mm

$L1 = (L) - 5 \times 2$

$L2 = L1 - 2 \times 8$

$LP = L2 / 2 - 50$

$LM = LP + 50$

$LF = L2 - LP$

X = CALCOLARE / CALCULATE / BERECHNEN

$HM = H - 40$

PROFILI A TERRA / FLOOR PROFILES / BODENPROFILE ▶ 88
▲ BX-PT-01 STANDARD HF = H - 43 = 1957 mm HFL = H - 3

xme551b

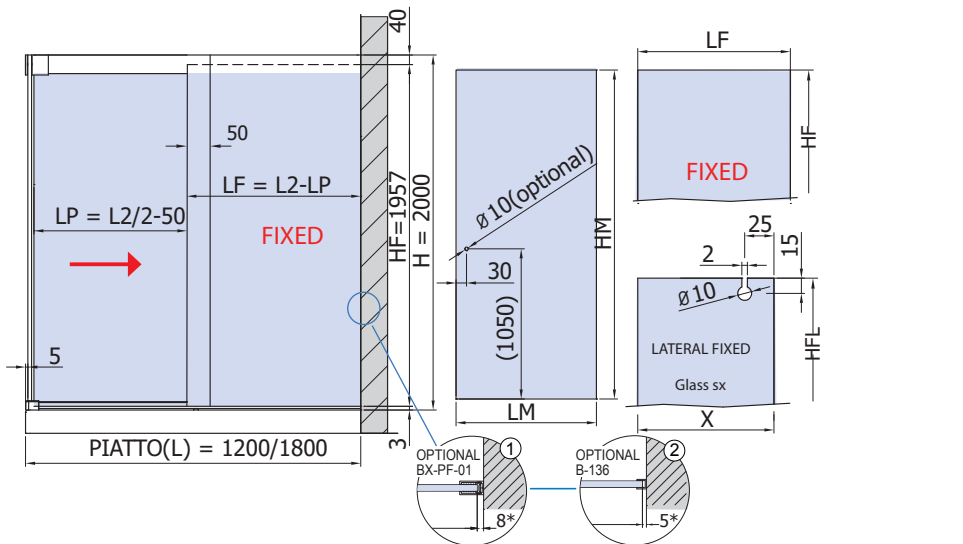
CALCOLO VETRO / CALCULATION GLASS / GLASBERECHNUNG

PIATTO - SHOWER TRAY - DUSCHTASSE (L) = 1200 - 1800 mm

$L1 = (L) - 5$

$L2 = L1 - 8$

$LP = L2 / 2 - 50$

$LM = LP + 50$

$LF = L2 - LP - * \textcircled{1} / * \textcircled{2}$ (aria variabile / clearance / Spaltmaß)

X = CALCOLARE / CALCULATE / BERECHNEN

$HM = H - 40$

PROFILI A TERRA / FLOOR PROFILES / BODENPROFILE ▶ 88
▲ BX-PT-01 STANDARD HF = H - 43 = 1957 mm HFL = H - 3

xme551b

SET 3 / SET 4

DA TAGLIARE / ADJUST THE LENGTH / BELIEBIG KÜRZBAR ✂

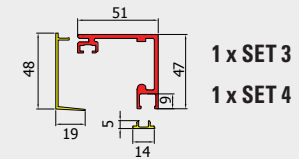

1 x SET 3

1 x SET 4

- Regolazione ruota ± 2,5 mm.
- Adjustment ± 2,5 mm.
- Verstellung ± 2,5 mm.

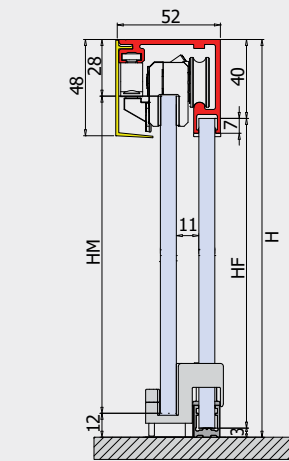

$HM = H - 40$

 HF = H - 43
 solo per / only for / nur für
▲ BX-PT-01
OPTIONAL

L	LP	LM	LF	HM	HF	H	HFL
Piatto Shower tray Duschtaße	Passaggio luce Clear opening width Lichte Durchgangsbreite	Larghezza vetro mobile Sliding glass width Schiebeflügel Breite	Larghezza vetro fisso Side fixed glass width Seitenteil Breite	Altezza vetro mobile Sliding glass height Schiebeflügel Höhe	Altezza vetro fisso Side fixed glass height Seitenteil Höhe	Altezza doccia Shower height Duschcabine Höhe	Altezza vetro fisso laterale Side fixed glass height Seitenteil (seitlich) Höhe

BX-3100

COMPONENTI / COMPONENTS / EINZELTEILE

SCORREVOLI



BX-3100-C40/C43

- Binario con veletta, profilo di chiusura per sede vetro fisso BX-4001 incluso
- Track profile with cover, profile for fixed glass section BX-4001 included
- Laufschiene mit Profilabdeckung, Sichtschutzprofil für Seitenteil Sektor BX-4001 enthalten

CR - NO

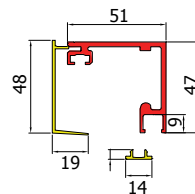

Cod.	Fin. / Fin. / Oberf.
BX-3100-C43-1500 mm	CR / NO
BX-3100-C43-3000 mm	CR / NO
BX-3100-C40-1000 x 1000 mm (2 pcs 45°)	CR / NO

e▶ B.51

xme551d



BX-3100-C10

- Set composto da 2 carrelli e 2 stopper
- Set consisting of 2 roller carriers and 2 stoppers
- Set bestehend aus 2 Klemm-Laufwagen und 2 Stopper

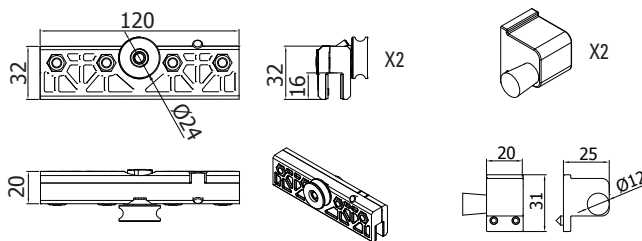

e▶ B.52

xme551c



BX-3100-C90 DX

- Attacco a parete destro per binario
- Right wall connector for track profile
- Wandhalter rechts für Laufschiene

CR - NO

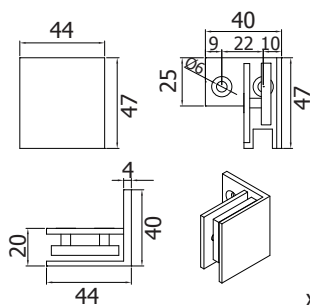

xme551c

e▶ B.55



BX-3100-C90 SX

- Attacco a parete sinistro per binario
- Left wall connector for track profile
- Wandhalter links für Laufschiene

CR - NO

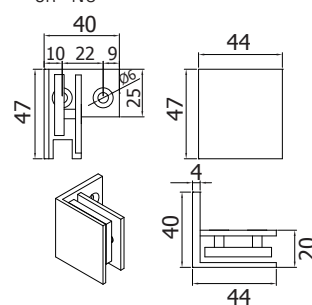

xme551c

e▶ B.56



BX-3100-C81 DX

- Piastrina destra attacco a vetro per BX-3100-C90
- Right plate glass connector for BX-3100-C90
- Platte Glashalter rechts für BX-3100-C90

CR - NO

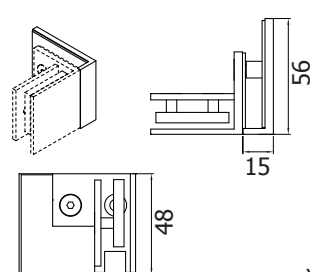

xme551c

e▶ B.57



BX-3100-C81 SX

- Piastrina sinistra attacco a vetro per BX-3100-C90
- Left plate glass connector for BX-3100-C90
- Platte Glashalter links für BX-3100-C90

CR - NO

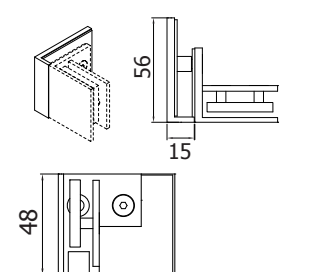

xme551c

e▶ B.58

BX-3100-C20

- Connettore ad angolo per binario per set 1
- Corner connector for track profile set 1
- Winkelverbinder Laufschiene set 1

CR - NO

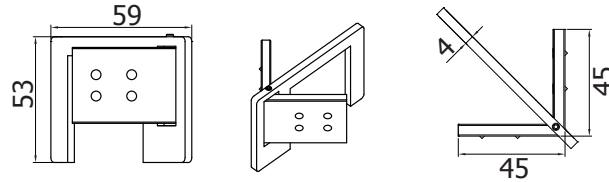

B.59

xme551c

BX-3150

- Guida vetro scorrevole BX-3150 per applicazione con profilo a terra BX-PT-C58 sistema di sgancio della porta per facilitare la pulizia.
- Floor guide sliding panel BX-3150 for installation with floor profile BX-PT-C58 with quick release door function for easy cleaning.
- Schiebetür Bodenführung BX-3150 für Montage mit Bodenprofil BX-PT-C58 mit auslosbarem System um das Reiningen zu erleichtern.

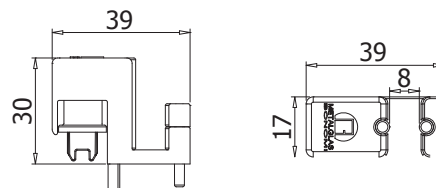
CR - NO

B.53

xme551c

BX-3106

- Optional Soft-close

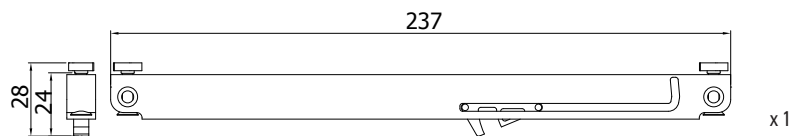
B.54

xme551d

BX-PT-C58

- Profilo a terra
- Floor profile
- Bodenprofil

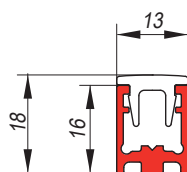

Cod.	Fin./Fin./Fin.
BX-PT-C58-1500 mm	CR / NO
BX-PT-C58-3000 mm	CR / NO

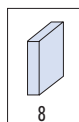
B.101

BX-PT-C56

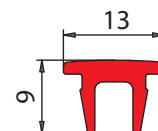
- Coperchio per profilo a terra per tratto entrata doccia
- Cover profile for floor profile, shower entry.
- Profilabdeckung Bodenprofil Duscheinstieg



Cod.	Fin./Fin./Fin.
BX-PT-C56-1500 mm	CR / NO
BX-PT-C56-3000 mm	CR / NO

B.102

BX-1501



SCORREVOLI



- Sistema scorrevole per box doccia disponibile per versioni in angolo, lineare e in nicchia. Possibilità di regolazione tramite ruota ± 3 mm.
- Sliding system for shower box, available for corners, single doors or for niche installations. Adjustment of carrying wheels ± 3 mm.
- Schiebetürsystem für Duschkabinen, lieferbar für Eck-, Linear und Nischenduschen. Höheneinstellung der Räder ± 3 mm.

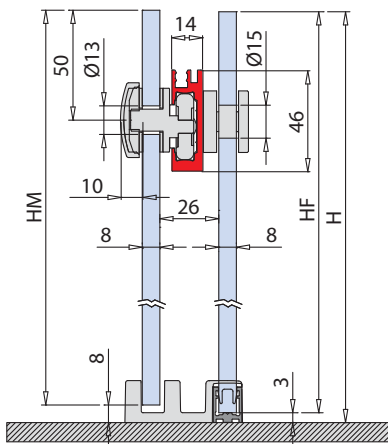

SCORREVOLI



 SET 1 [e▶ B.60](#)

 SET 2 [e▶ B.61](#)

 SET 3 [e▶ B.62](#)

 SET 4 [e▶ B.63](#)

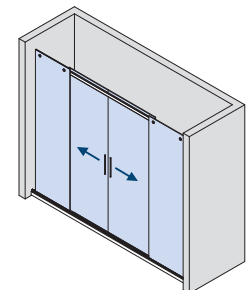
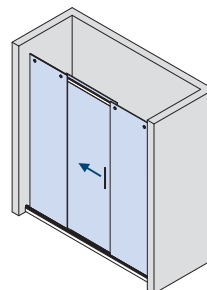
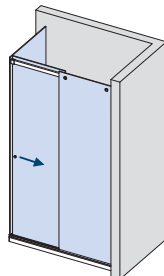
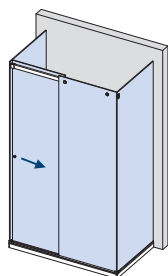
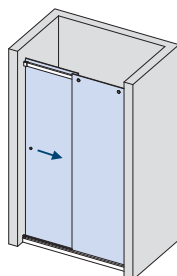
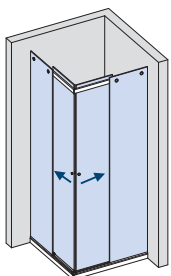
 SET 5 [e▶ B.64](#)

 SET 6 [e▶ B.65](#)

BX-1501 SET 1

L = 1000 x 1000 mm

DOCCIA IN ANGOLO / CORNER SHOWER / ECKDUSCHE

e▶ B.60

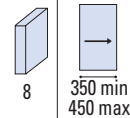

Fin. / Fin. / Oberf.

CR Cromo lucido Polished chrome Chrom glänzend	IXE Effetto inox Inox effect Inox effekt
--	--

COMPONENTI / COMPONENTS / EINZELTEILE

- BX-1501-C90 (2x)
- BX-1501-C30 (2x)
- BX-1501-C70 (4x)
- BX-1501-C10 (4x)
- BX-1501-C20 (1x)
- OPTIONAL

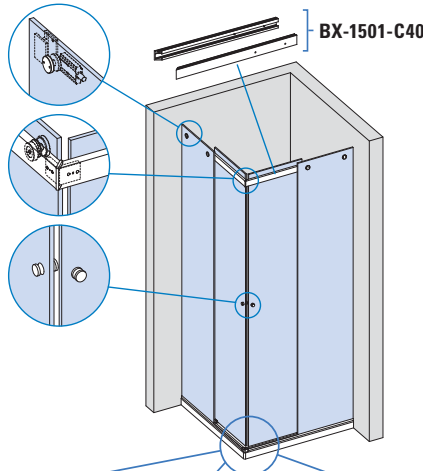

CARATTERISTICHE COMPONENTI /
FEATURES COMPONENTS /
EIGENSCHAFTEN EINZELTEILE ▶ 54

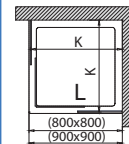
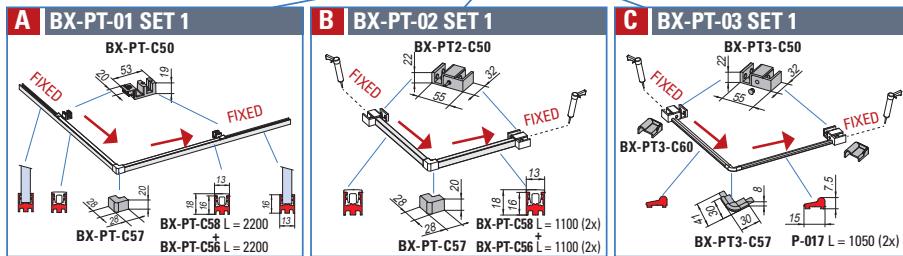

PROFILI A TERRA / FLOOR PROFILES / BODENPROFILE ▶ 88

xfb-050-A

BX-1501 SET 2

L = 1500 mm / L = 3000 mm

DOCCIA IN NICCHIA / NICHE SHOWER / NISCHENDUSCHE

e▶ B.61

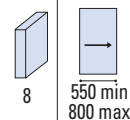

Fin. / Fin. / Oberf.

CR Cromo lucido Polished chrome Chrom glänzend	IXE Effetto inox Inox effect Inox effekt
--	--

COMPONENTI / COMPONENTS / EINZELTEILE

- BX-1501-C90 (2x)
- BX-1501-C10 (2x)
- BX-1501-C70 (2x)
- BX-1501-C30 (1x)
- OPTIONAL

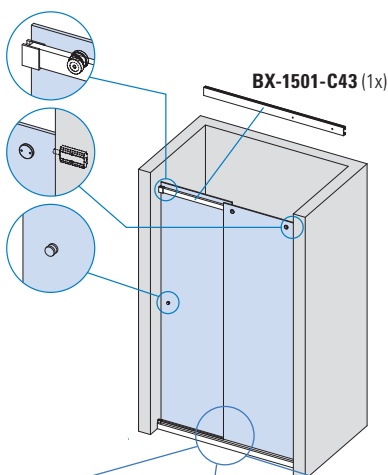

CARATTERISTICHE COMPONENTI /
FEATURES COMPONENTS /
EIGENSCHAFTEN EINZELTEILE ▶ 54

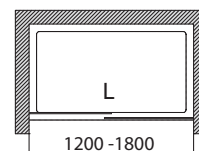
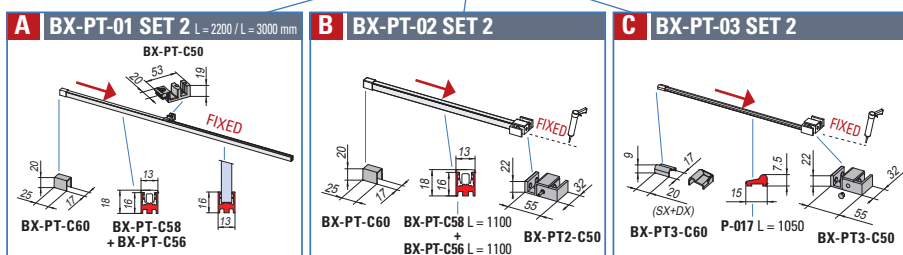

PROFILI A TERRA / FLOOR PROFILES / BODENPROFILE ▶ 88

xfb-050-B

LAVORAZIONE VETRO / GLASS PREPARATION / GLASBEARBEITUNG

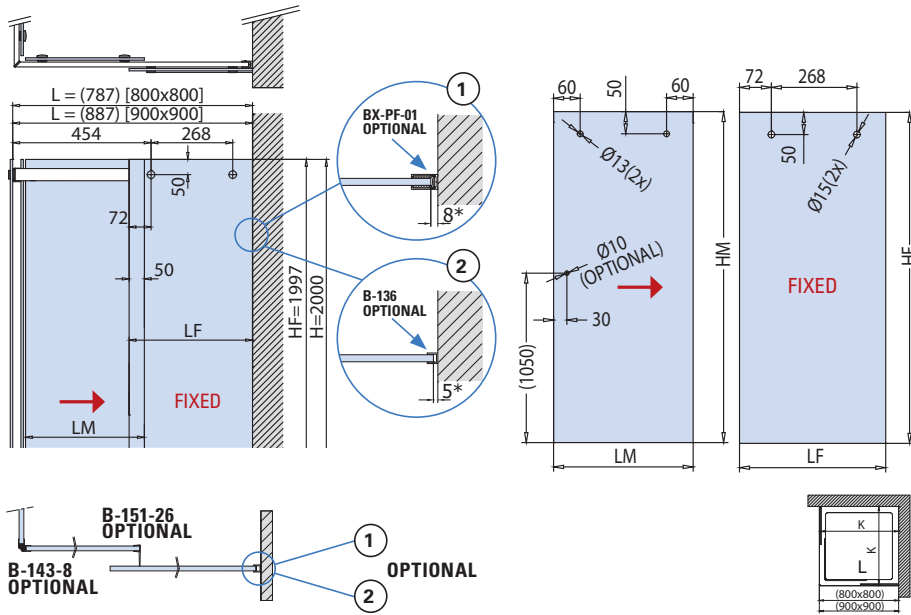

CALCOLO VETRO / CALCULATION GLASS / GLASBEREICHNUNG

L = 800 x 800 mm (900 x 900 mm)

LM = (L - 5) / 2

LF = [(L - 5) / 2] - * ① / * ② (aria variabile / clearance / Spaltmaß)

HM = H - 8 = 1992 mm

PROFILI A TERRA / FLOOR PROFILES / BODENPROFILE ▶ 88

A BX-PT-01 STANDARD HF = H - 3 = 1997 mm

B BX-PT-02 OPTIONAL HF = H = 2000 mm

C BX-PT-03 OPTIONAL HF = H = 2000 mm

xfb-050-A

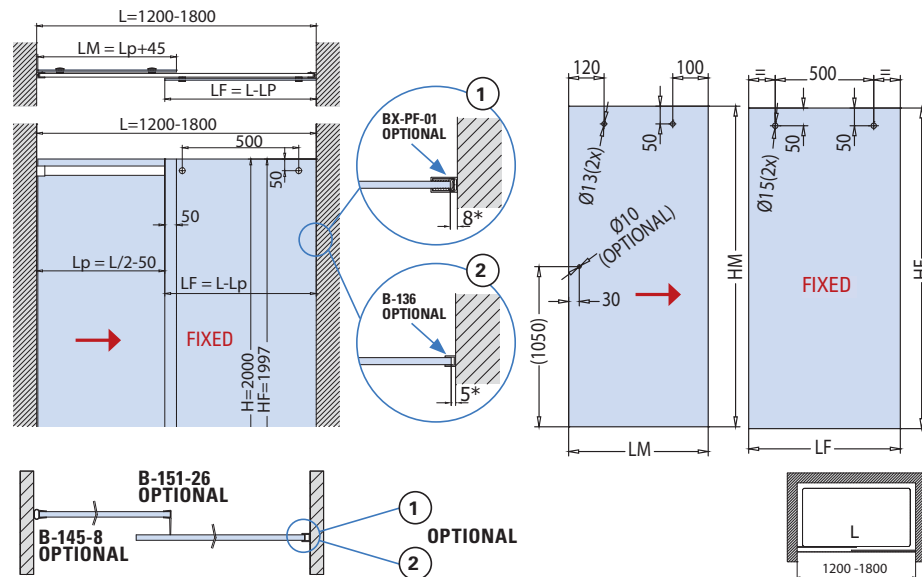

CALCOLO VETRO / CALCULATION GLASS / GLASBEREICHNUNG

L = 1200 mm → 1800 mm

LP = L / 2 - 50

LM = LP + 45

LF = L - LP - * ① / * ② (aria variabile / clearance / Spaltmaß)

HM = H - 8 = 1992 mm

PROFILI A TERRA / FLOOR PROFILES / BODENPROFILE ▶ 88

A BX-PT-01 STANDARD HF = H - 3 = 1997 mm

B BX-PT-02 OPTIONAL HF = H = 2000 mm

C BX-PT-03 OPTIONAL HF = H = 2000 mm

xfb-050-B

L
Piatto
Shower tray
Duschtaße

LM
Larghezza vetro mobile
Sliding glass width
Schiebeflügel Breite

LF
Larghezza vetro fisso
Side fixed glass width
Seitenteil Breite

HM
Altezza vetro mobile
Sliding glass height
Schiebeflügel Höhe

HF
Altezza vetro fisso
Side fixed glass height
Seitenteil Höhe

H
Altezza doccia
Shower height
Duschcabine Höhe

SET 1 / SET 2

DA TAGLIARE / ADJUST THE LENGTH / BELIEBIG KÜRZBAR ✂

- Forature per fissaggio vetro fisso (fatte dall'installatore).
- Holes in profile for fixed glass.
- Profile not predrilled.
- Bohrungen im Profil für Seitenteil Befestigung. Profil nicht vorgebohrt.

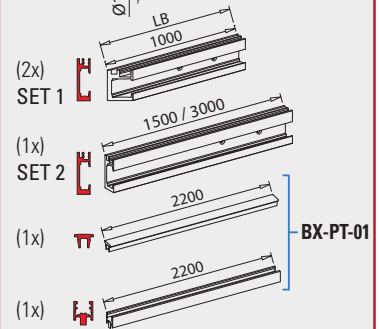
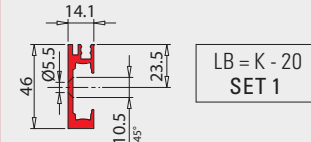

- Regolazione ruota ± 3 mm.
- Adjustment ± 3 mm.
- Verstellung ± 3 mm.

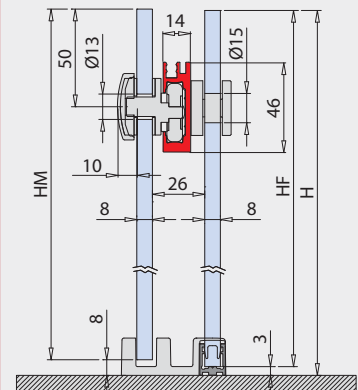

HF = H - 3
solo per / only for / nur für **A** BX-PT-01

OPTIONAL



BX-1501 SET 3

L = 1500 mm / L = 3000 mm
DOCCIA A U / U SHOWER / U DUSCHE

e► B.62

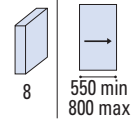

Fin. / Fin. / Oberf.

CR Cromo lucido Polished chrome Chrom glänzend	IXE Effetto inox Inox effect Inox effekt
--	--

COMPONENTI / COMPONENTS / EINZELTEILE

- BX-1501-C80 (2x)
- BX-1501-C10 (2x)
- BX-1501-C70 (2x)
- BX-1501-C30 (1x)
- OPTIONAL

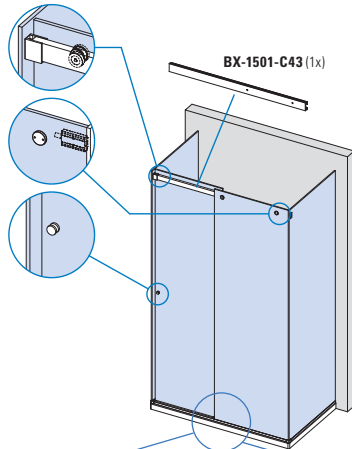

CARATTERISTICHE COMPONENTI /
FEATURES COMPONENTS /
EIGENSCHAFTEN EINZELTEILE ► 52

A BX-PT-01 SET 3 L = 2200 / L = 3000 mm

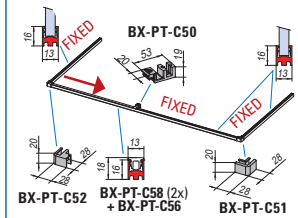

B BX-PT-02 SET 3

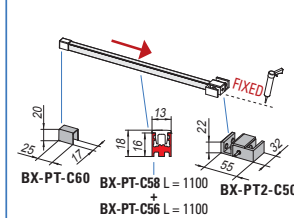

C BX-PT-03 SET 3

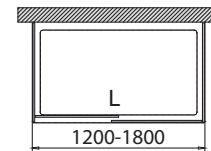
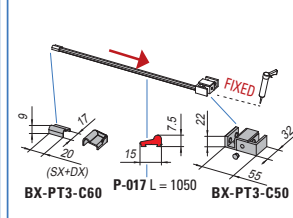

PROFILI A TERRA / FLOOR PROFILES / BODENPROFILE ► 88

xfb-050-C

BX-1501 SET 4

L = 1500 mm / L = 3000 mm
DOCCIA CON SPALLA IN VETRO / CORNER SHOWER WITH 2 FIXED PANEL /
ECKDUSCHE MIT 2 FESTSTEHENDEN GLASTAFELN

e► B.63

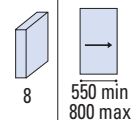

Fin. / Fin. / Oberf.

CR Cromo lucido Polished chrome Chrom glänzend	IXE Effetto inox Inox effect Inox effekt
--	--

COMPONENTI / COMPONENTS / EINZELTEILE

- BX-1501-C80 (1x)
- BX-1501-C10 (2x)
- BX-1501-C70 (2x)
- BX-1501-C90 (1x)
- BX-1501-C30 (1x)
- OPTIONAL

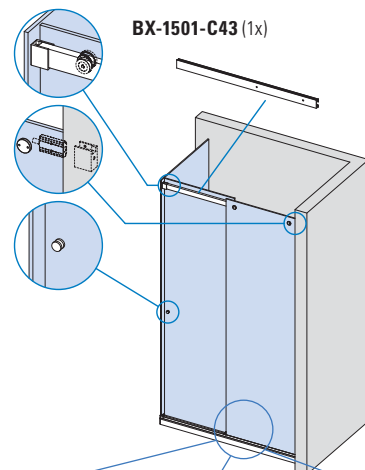

CARATTERISTICHE COMPONENTI /
FEATURES COMPONENTS /
EIGENSCHAFTEN EINZELTEILE ► 52

A BX-PT-01 SET 4 L = 2200 / L = 3000 mm

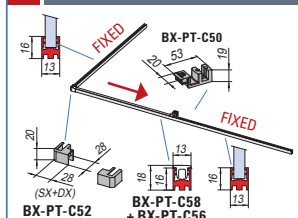

B BX-PT-02 SET 4

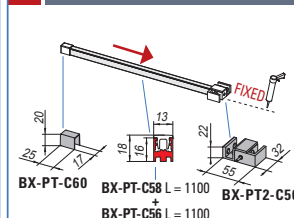

C BX-PT-03 SET 4

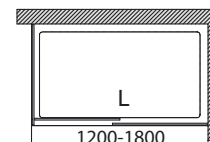
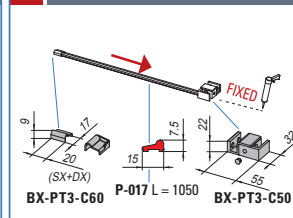

PROFILI A TERRA / FLOOR PROFILES / BODENPROFILE ► 88

xfb-050-D

SCORREVOLI

LAVORAZIONE VETRO / GLASS PREPARATION / GLASBEARBEITUNG

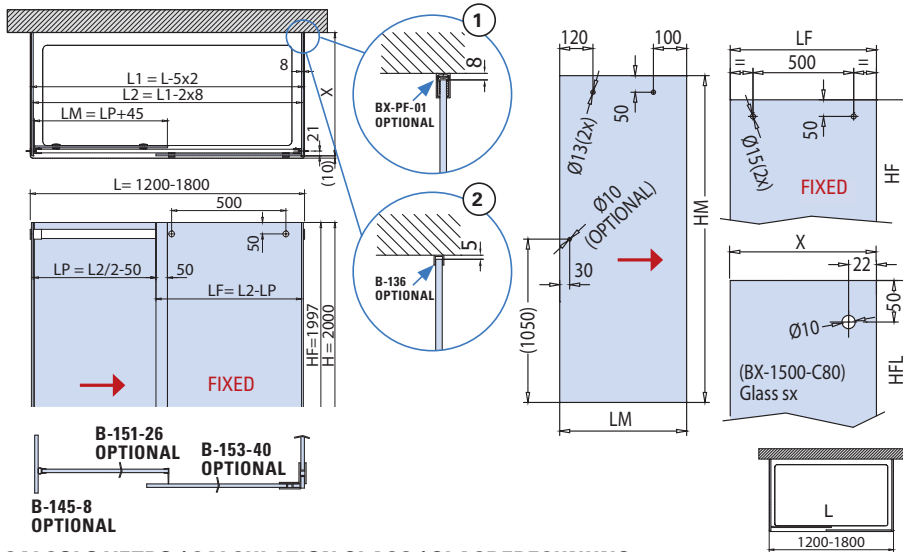

CALCOLO VETRO / CALCULATION GLASS / GLASBERECHNUNG

L = 1200 mm → 1800 mm

L1 = L - 5 x 2

L2 = L1 - 2 x 8

LP = L2 / 2 - 50

LM = LP + 45

LF = L2 - LP

X = calcolare / calculate / berechnen

X = vedi ① ② / see ① ② / siehe ① ②

PROFILI A TERRA / FLOOR PROFILES / BODENPROFILE ▶ 88

▲ BX-PT-01 STANDARD HF = H - 3 = 1997 mm HFL = H - 3

▣ BX-PT-02 OPTIONAL HF = H = 2000 mm HFL = H

▣ BX-PT-03 OPTIONAL HF = H = 2000 mm HFL = H

xfb-050-C

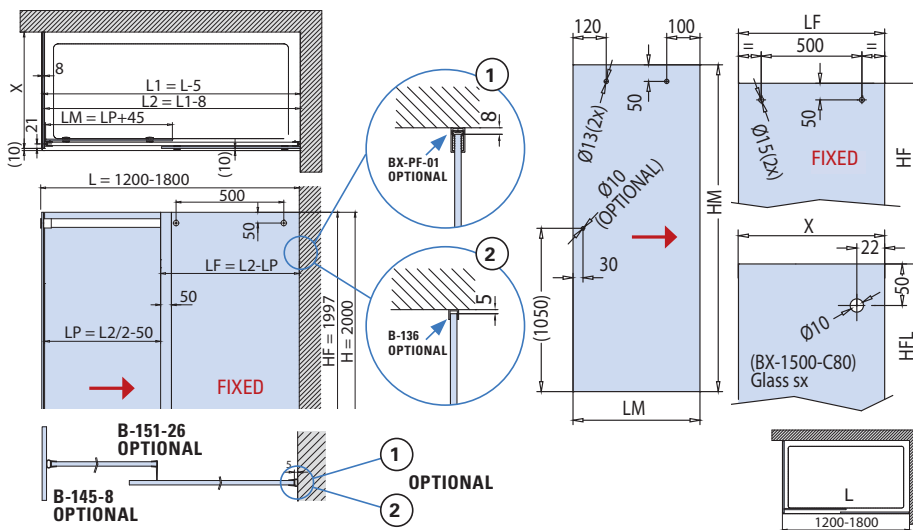

CALCOLO VETRO / CALCULATION GLASS / GLASBERECHNUNG

L = 1200 mm → 1800 mm

L1 = L - 5

L2 = L1 - 8

LP = L2 / 2 - 50

LM = LP + 45

LF = (L2 - LP) - * ① / * ② (aria variabile / clearance / Spaltmaß)

X = calcolare / calculate / berechnen

X = vedi ① ② / see ① ② / siehe ① ②

PROFILI A TERRA / FLOOR PROFILES / BODENPROFILE ▶ 88

▲ BX-PT-01 STANDARD HF = H - 3 = 1997 mm HFL = H - 3

▣ BX-PT-02 OPTIONAL HF = H = 2000 mm HFL = H

▣ BX-PT-03 OPTIONAL HF = H = 2000 mm HFL = H

xfb-050-D

SET 3 / SET 4

DA TAGLIARE / ADJUST THE LENGTH / BELIEBIG KÜRZBAR ✂

- Forature per fissaggio vetro fisso (fatte dall'installatore).
- Holes in profile for fixed glass.
- Profile not predrilled.
- Bohrungen im Profil für Seitenteil Befestigung. Profil nicht vorgebohrt.

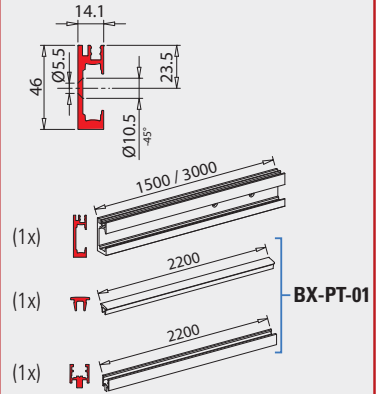

- Regolazione ruota ± 3 mm.
- Adjustment ± 3 mm.
- Verstellung ± 3 mm.

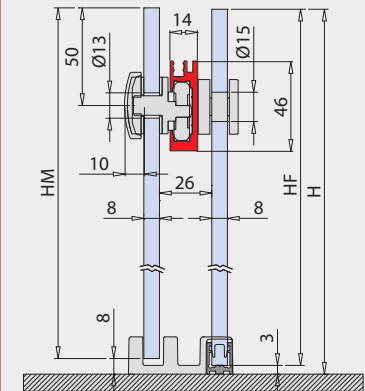

HM = H - 8

HF = H - 3

solo per / only for / nur für ▲ BX-PT-01

OPTIONAL



L	LP	LM	LF	HM	HF	H	HFL
Piatto Shower tray Duschtaße	Passaggio luce Clear opening width Lichte Durchgangsbreite	Larghezza vetro mobile Sliding glass width Schiebeflügel Breite	Larghezza vetro fisso Side fixed glass width Seitenteil Breite	Altezza vetro mobile Sliding glass height Schiebeflügel Höhe	Altezza vetro fisso Side fixed glass height Seitenteil Höhe	Altezza doccia Shower height Duschcabinen Höhe	Altezza vetro fisso laterale Side fixed glass height Seitenteil (seitlich) Höhe

BX-1501

COMPONENTI / COMPONENTS / EINZELTEILE

SCORREVOLI



BX-1501-C43

- Binario
- Track profile
- Laufschiene

B.67

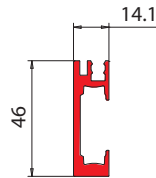

Cod.	Fin./Fin./Oberf.
BX-1501-C43-1500 mm	CR / IXE
BX-1501-C43-3000 mm	CR / IXE
BX-1501-C01-1000 x 1000 mm (2 pcs 45°)	CR / IXE

xfb-077



BX-1501-C10

- Ruota
- Roller
- Laufrolle

B.68

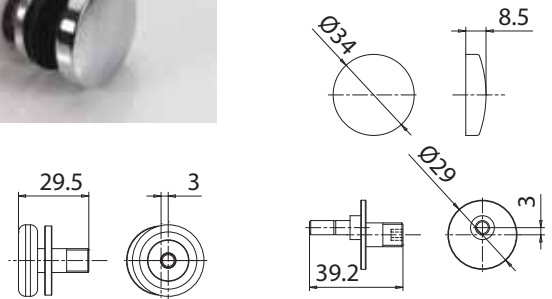

xfb-077



BX-1501-C70

- Punto di fissaggio vetro fisso al binario
- Fixing point for fixed glass and track profile
- Punkthalter für Fixierung des Festteils auf Laufschiene

B.69

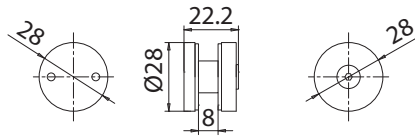

xfb-077



BX-1501-C90 DX

- Attacco a parete destro per binario
- Right wall connector for track profile
- Wandhalter rechts für Laufschiene

B.70

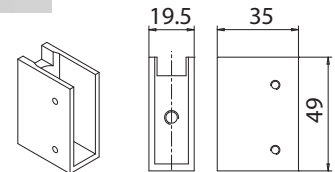

xfb-077



BX-1501-C90 SX

- Attacco a parete sinistro per binario
- Left wall connector for track profile
- Wandhalter links für Laufschiene

B.71

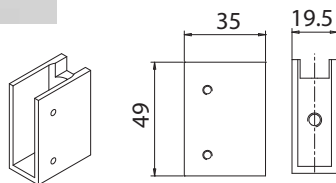

xfb-077



BX-1501-C81

- Piastrina attacco a vetro
- Plate glass connector for track profile
- Platte Glashalter

B.72

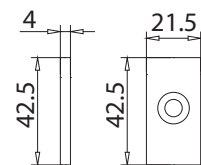

xfb-077



BX-1501-C30

- Stopper

B.73

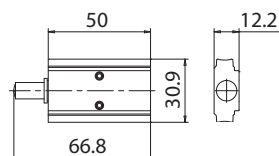

xfb-077



BX-1501-C20

- Connettore ad angolo per binario
- Corner connector for track profile
- Winkelverbinder Laufschiene

B.74

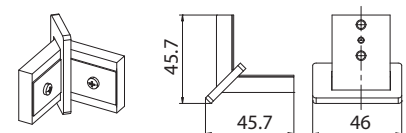

xfb-077



SCORREVOLI



BX-2000

SCORREVOLI



- Sistema scorrevole per box doccia disponibile per versioni in angolo, lineare e in nicchia. Possibilità di regolazione tramite ruota ± 2 mm.
- Sliding system for shower box, available for corners, single doors or for niche installations. Adjustment of carrying wheels ± 2 mm.
- Schiebetürsystem für Duschkabinen, lieferbar für Eck-, Linear und Nischenduschen. Höheneinstellung der Räder ± 2 mm.



SCORREVOLI

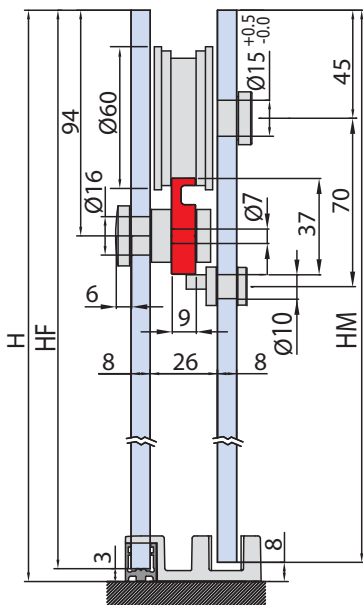

 SET 1 [e▶ B.75](#)

 SET 2 [e▶ B.76](#)

 SET 3 [e▶ B.77](#)

 SET 4 [e▶ B.78](#)

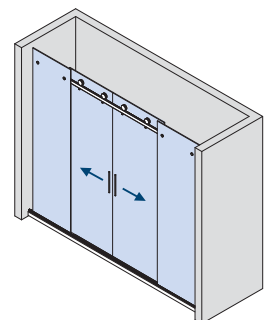
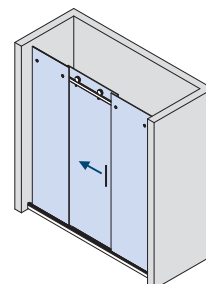
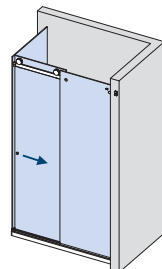
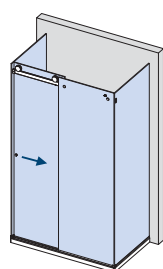
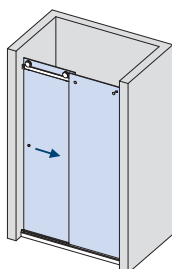
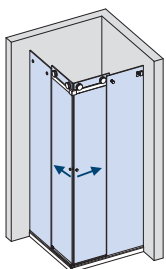
 SET 5 [e▶ B.79](#)

 SET 6 [e▶ B.80](#)

BX-2000 SET 1

L = 1000 x 1000 mm

DOCCIA IN ANGOLO / CORNER SHOWER / ECKDUSCHE

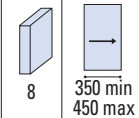

Fin. / Fin. / Oberf.

CR
Cromo lucido
Polished chrome
Chrom glänzend

e ▶ B.75

COMPONENTI / COMPONENTS / EINZELTEILE

- BX-2000-C07 (2x)
- BX-2000-C04 (4x)
- BX-2000-C02 (2x)
- BX-2000-C01 (4x)
- BX-2000-C03 (4x)
- BX-2000-C10 (1x)
- OPTIONAL

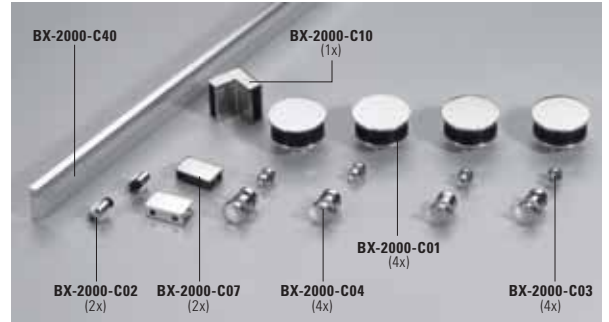
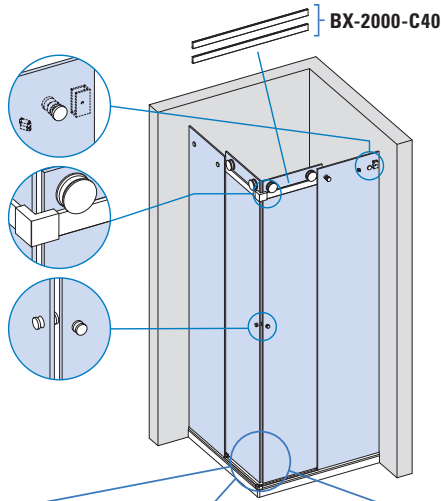

CARATTERISTICHE COMPONENTI /
FEATURES COMPONENTS /
EIGENSCHAFTEN EINZELTEILE ▶ 60

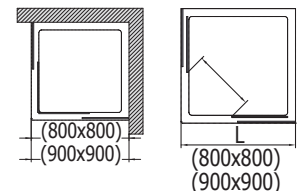
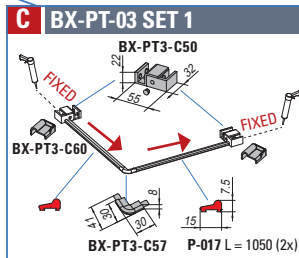
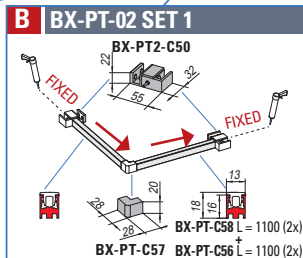
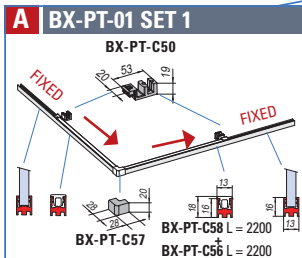

PROFILI A TERRA / FLOOR PROFILES / BODENPROFILE ▶ 88

xme216-A

BX-2000 SET 2

L = 1500 mm / L = 3000 mm

DOCCIA IN NICCHIA / NICHE SHOWER / NISCHENDUSCHE

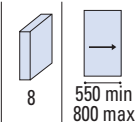

Fin. / Fin. / Oberf.

CR
Cromo lucido
Polished chrome
Chrom glänzend

e ▶ B.76

COMPONENTI / COMPONENTS / EINZELTEILE

- BX-2000-C01 (2x)
- BX-2000-C03 (2x)
- BX-2000-C07 (2x)
- BX-2000-C04 (2x)
- BX-2000-C02 (1x)
- OPTIONAL

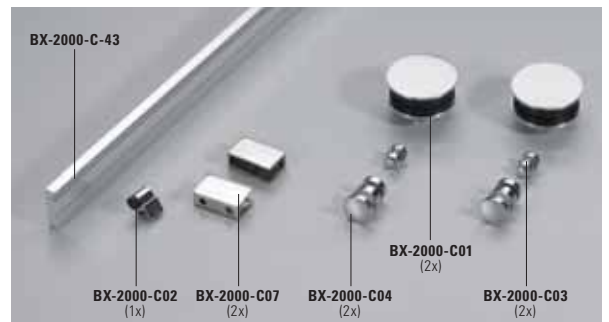
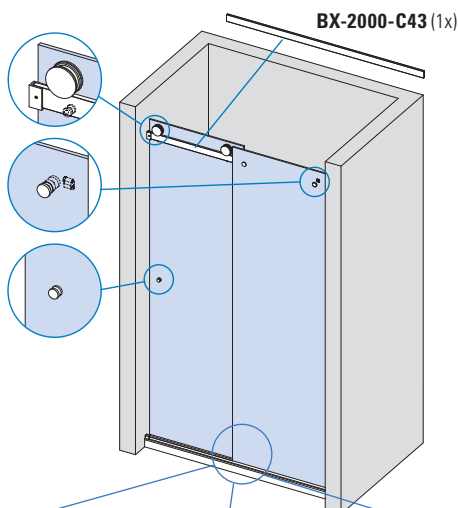

CARATTERISTICHE COMPONENTI /
FEATURES COMPONENTS /
EIGENSCHAFTEN EINZELTEILE ▶ 60

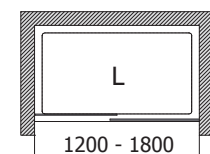
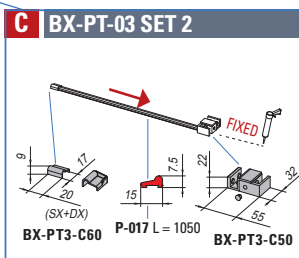
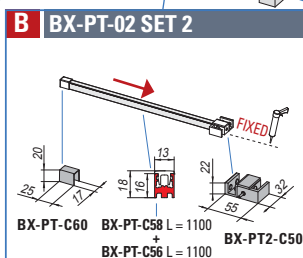
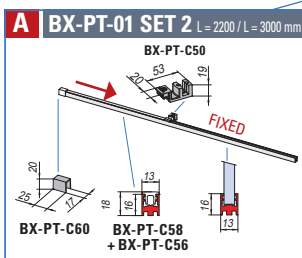

PROFILI A TERRA / FLOOR PROFILES / BODENPROFILE ▶ 88

xme217

LAVORAZIONE VETRO / GLASS PREPARATION / GLASBEARBEITUNG

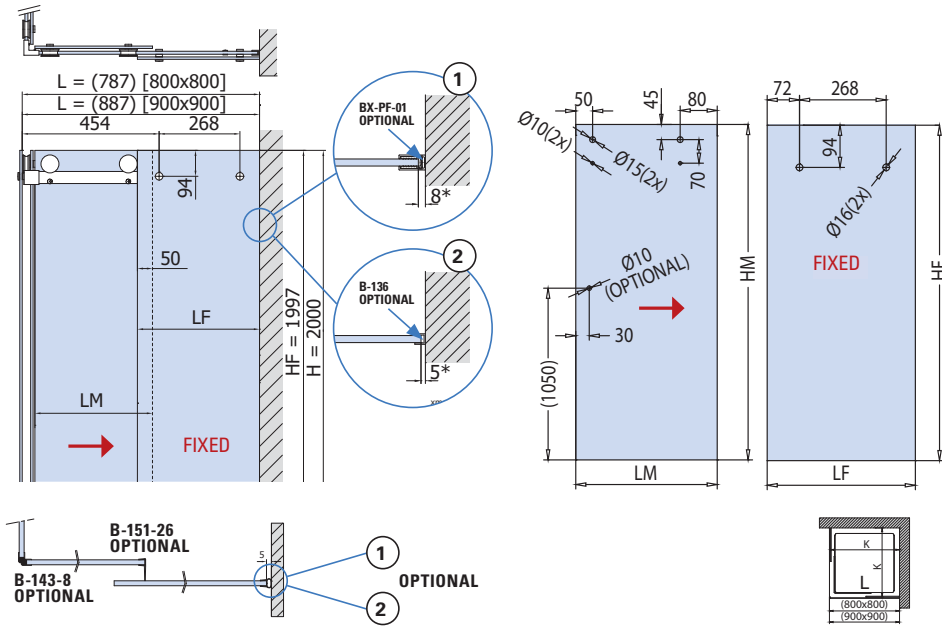

CALCOLO VETRO / CALCULATION GLASS / GLASBERECHNUNG

L = 800 x 800 mm (900 x 900 mm)

LM = (L - 5) / 2

LF = [(L - 5) / 2] - * ① / * ② (aria variabile / clearance / Spaltmaß)

HM = H - 8 = 1992 mm

PROFILI A TERRA / FLOOR PROFILES / BODENPROFILE ▶ 88

A BX-PT-01 STANDARD HF = H - 3 = 1997 mm

B BX-PT-02 OPTIONAL HF = H = 2000 mm

C BX-PT-03 OPTIONAL HF = H = 2000 mm

xme216 / xme-216-A

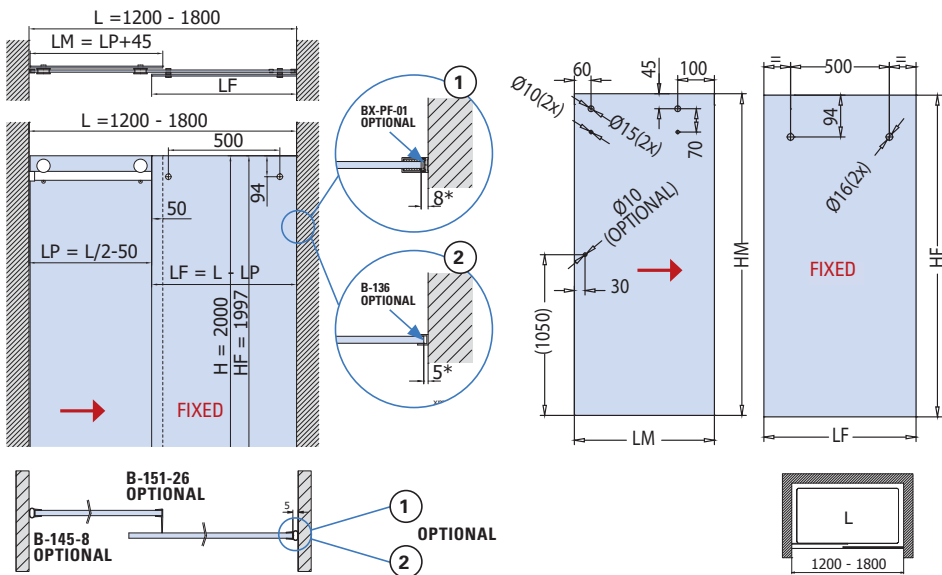

CALCOLO VETRO / CALCULATION GLASS / GLASBERECHNUNG

L = 1200 mm → 1800 mm

LP = L / 2 - 50

LM = LP + 45

LF = L - LP - * ① / * ② (aria variabile / clearance / Spaltmaß)

HM = H - 8 = 1992 mm

PROFILI A TERRA / FLOOR PROFILES / BODENPROFILE ▶ 88

A BX-PT-01 STANDARD HF = H - 3 = 1997 mm

B BX-PT-02 OPTIONAL HF = H = 2000 mm

C BX-PT-03 OPTIONAL HF = H = 2000 mm

xme216-A / xme217-1

SET 1 / SET 2

DA TAGLIARE / ADJUST THE LENGTH / BELIEBIG KÜRZBAR ✂

- Forature per fissaggio vetro fisso (fatte dall'installatore).
- Holes in profile for fixed glass.
- Profile not predrilled.
- Bohrungen im Profil für Seitenteil Befestigung. Profil nicht vorgebohrt.

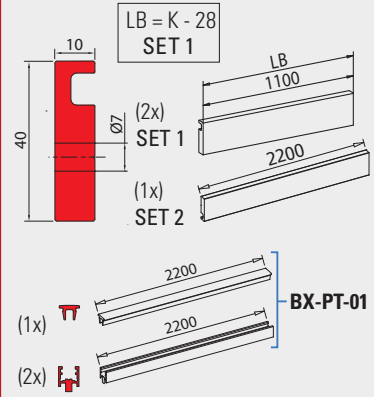

- Regolazione ruota ± 2 mm.
- Adjustment ± 2 mm.
- Verstellung ± 2 mm.

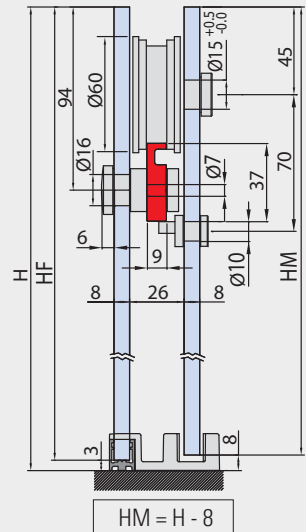

HF = H - 3
solo per / only for / nur für **A BX-PT-01**

OPTIONAL



L	LP	LM	LF	HM	HF	H
Piatto Shower tray Duschtaße	Passaggio luce Clear opening width Lichte Durchgangsbreite	Larghezza vetro mobile Sliding glass width Schiebeflügel Breite	Larghezza vetro fisso Side fixed glass width Seitenteil Breite	Altezza vetro mobile Sliding glass height Schiebeflügel Höhe	Altezza vetro fisso Side fixed glass height Seitenteil Höhe	Altezza doccia Shower height Duschcabine Höhe

BX-2000 SET 3

L = 2000 mm

DOCCIA A U / U SHOWER / U DUSCHE

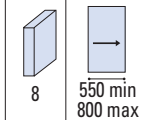

Fin. / Fin. / Oberf.

CR
Cromo lucido
Polished chrome
Chrom glänzend

e▶ B.77

COMPONENTI / COMPONENTS / EINZELTEILE

BX-2000-C08 (2x)

BX-2000-C01 (2x)

BX-2000-C03 (2x)

BX-2000-C02 (1x)

BX-2000-C04 (4x)

OPTIONAL

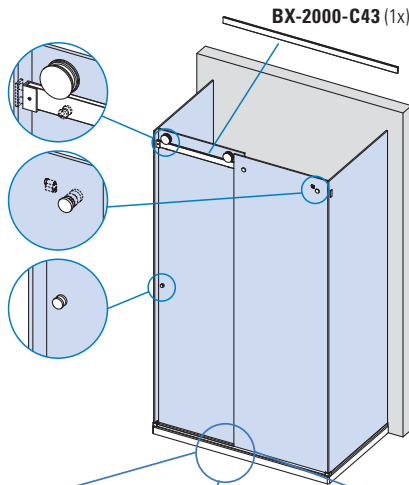

CARATTERISTICHE COMPONENTI / FEATURES COMPONENTS / EIGENSCHAFTEN EINZELTEILE ▶ 60

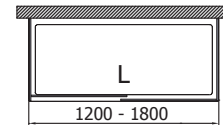
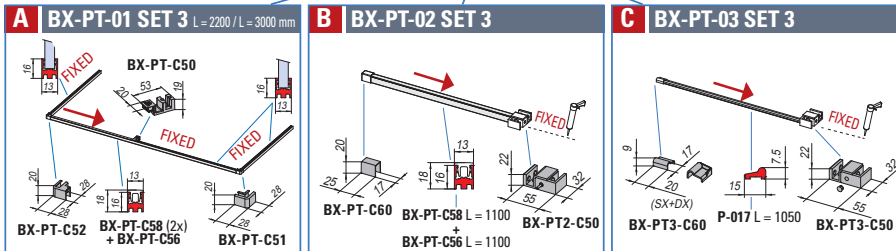

PROFILI A TERRA / FLOOR PROFILES / BODENPROFILE ▶ 88

xme216-A

BX-2000 SET 4

L = 2000 mm

DOCCIA CON SPALLA IN VETRO / CORNER SHOWER WITH 2 FIXED PANEL
ECKDUSCHE MIT 2 FESTSTEHENDEN GLASTAFELN

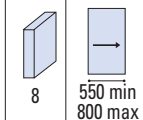

Fin. / Fin. / Oberf.

CR
Cromo lucido
Polished chrome
Chrom glänzend

e▶ B.78

COMPONENTI / COMPONENTS / EINZELTEILE

BX-2000-C08 (1x)

BX-2000-C01 (2x)

BX-2000-C03 (2x)

BX-2000-C02 (1x)

BX-2000-C04 (2x)

BX-2000-C07 (1x)

OPTIONAL

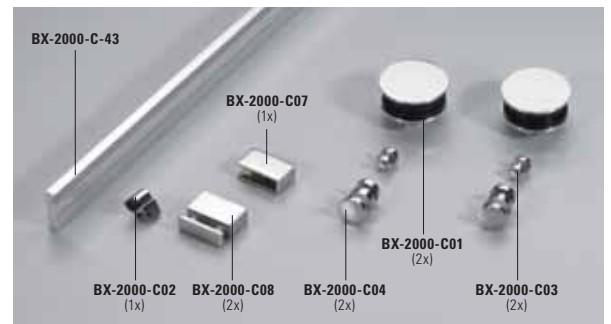
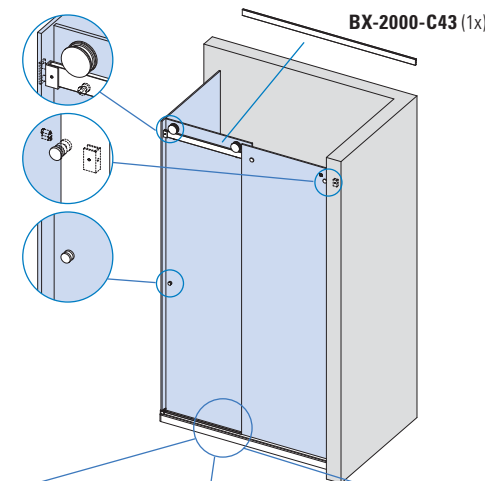

CARATTERISTICHE COMPONENTI / FEATURES COMPONENTS / EIGENSCHAFTEN EINZELTEILE ▶ 60

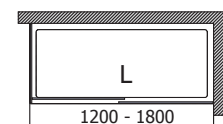
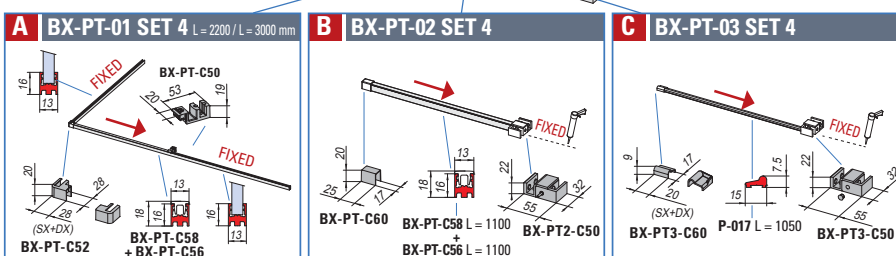

PROFILI A TERRA / FLOOR PROFILES / BODENPROFILE ▶ 88

xme219

SCORREVOLI

LAVORAZIONE VETRO / GLASS PREPARATION / GLASBEARBEITUNG

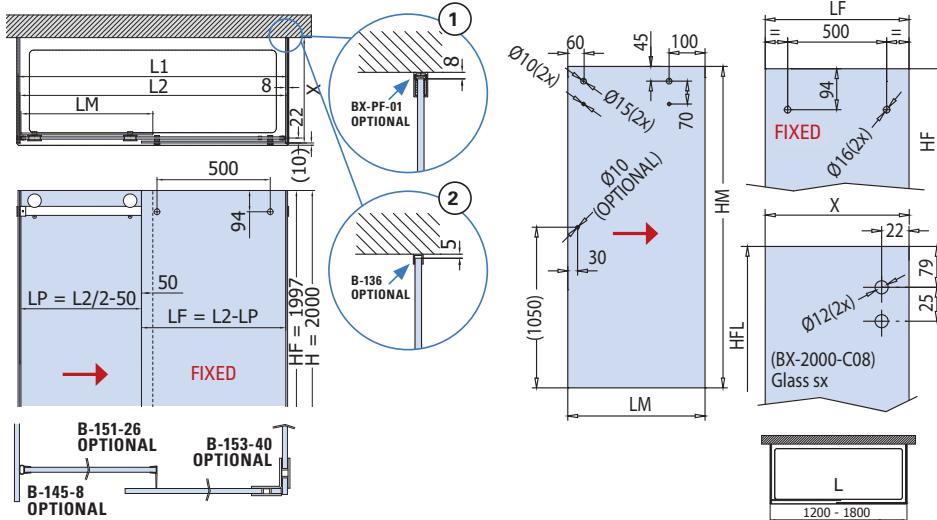

CALCOLO VETRO / CALCULATION GLASS / GLASBERECHNUNG

$L = 1200 \text{ mm} \rightarrow 1800 \text{ mm}$
 $L1 = L - 5 \times 2$
 $L2 = L1 - 2 \times 8$
 $LP = L2 / 2 - 50$
 $LM = LP + 45$
 $LF = L2 - LP$
 X = calcolare / calculate / berechnen
 X = vedi (1)(2) / see (1)(2) / siehe (1)(2)
 $HM = H - 8 = 1992 \text{ mm}$

PROFILI A TERRA / FLOOR PROFILES / BODENPROFILE ▶ 88

- A** BX-PT-01 STANDARD HF = H - 3 = 1997 mm HFL = H - 3
- B** BX-PT-02 OPTIONAL HF = H = 2000 mm HFL = H
- C** BX-PT-03 OPTIONAL HF = H = 2000 mm HFL = H

xme216 / xme-216-A

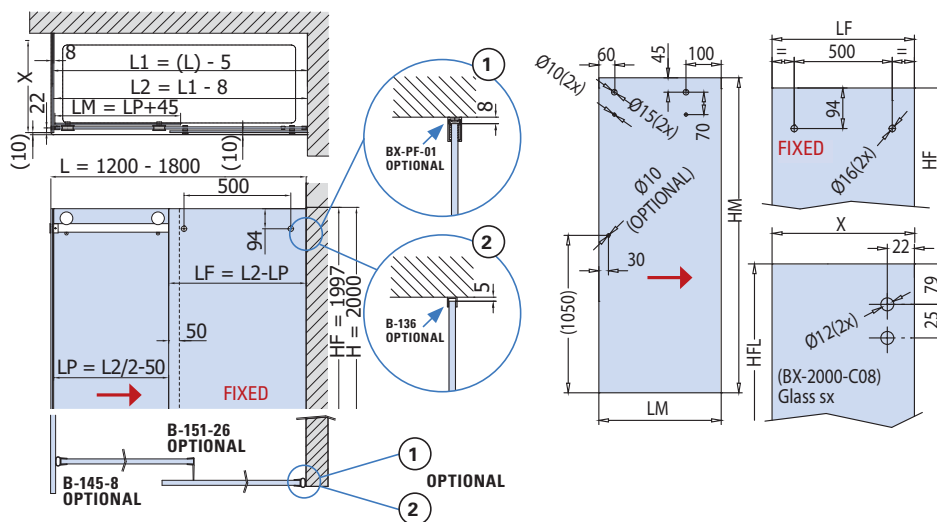

CALCOLO VETRO / CALCULATION GLASS / GLASBERECHNUNG

$L = 1200 \text{ mm} \rightarrow 1800 \text{ mm}$
 $L1 = L - 5$
 $L2 = L1 - 8$
 $LP = L2 / 2 - 50$
 $LM = LP + 45$
 $LF = (L2 - LP) \cdot * (1) / * (2)$ (aria variabile / clearance / Spaltmaß)
 X = calcolare / calculate / berechnen
 X = vedi (1)(2) / see (1)(2) / siehe (1)(2)

PROFILI A TERRA / FLOOR PROFILES / BODENPROFILE ▶ 88

- A** BX-PT-01 STANDARD HF = H - 3 = 1997 mm HFL = H - 3
- B** BX-PT-02 OPTIONAL HF = H = 2000 mm HFL = H
- C** BX-PT-03 OPTIONAL HF = H = 2000 mm HFL = H

xme216-A / xme219-1

SET 3 / SET 4

DA TAGLIARE / ADJUST THE LENGTH / BELIEBIG KÜRZBAR ✂

- Forature per fissaggio vetro fisso (fatte dall'installatore).
- Holes in profile for fixed glass.
- Profile not predrilled.
- Bohrungen im Profil für Seitenteil Befestigung. Profil nicht vorgebohrt.

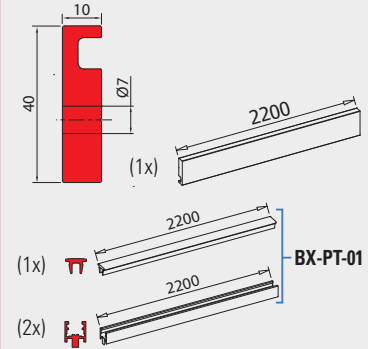

- Regolazione ruota $\pm 2 \text{ mm}$.
- Adjustment $\pm 2 \text{ mm}$.
- Verstellung $\pm 2 \text{ mm}$.

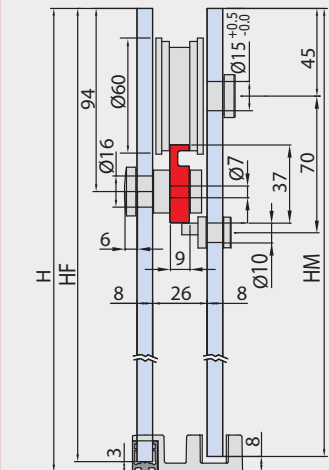

HM = H - 8

HF = H - 3

solo per / only for / nur für **A** BX-PT-01

OPTIONAL



L	LP	LM	LF	HM	HF	H	HFL
Piatto Shower tray Duschtaße	Passaggio luce Clear opening width Lichte Durchgangsbreite	Larghezza vetro mobile Sliding glass width Schiebeflügel Breite	Larghezza vetro fisso Side fixed glass width Seitenteil Breite	Altezza vetro mobile Sliding glass height Schiebeflügel Höhe	Altezza vetro fisso Side fixed glass height Seitenteil Höhe	Altezza doccia Shower height Duschcabine Höhe	Altezza vetro fisso laterale Side fixed glass height Seitenteil (seitlich) Höhe

BX-2000

COMPONENTI / COMPONENTS / EINZELTEILE

SCORREVOLI



**BX-2000-C43/
BX-2000-C40**

- Binario
- Track profile
- Laufschiene

e▶ B.82

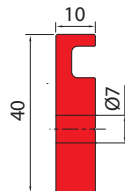

Cod.	Fin./Fin./Oberf.
BX-2000-C43-2200 mm	CR
BX-2000-C40-1000 x 1000 mm (2 pcs)	CR

xme 216



BX-2000-C01

- Ruota
- Roller
- Laufrolle

e▶ B.83

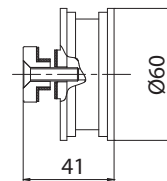

xfb-065



BX-2000-C03

- Antisgancio
- Anti-jump
- Aushebeschutz

e▶ B.84

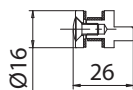

xfb-065



BX-2000-C04

- Punto di fissaggio vetro fisso al binario
- Fixing point for fixed glass and track profile
- Punkthalter für Fixierung des Festteils auf Laufschiene

e▶ B.85

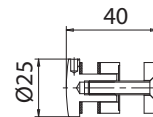

xfb-065



BX-2000-C07 DX

- Attacco a parete destro per binario
- Right wall connector for track profile
- Wandhalter rechts für Laufschiene

e▶ B.86

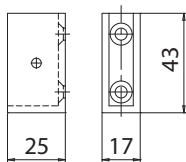

xfb-065



BX-2000-C07 SX

- Attacco a parete sinistro per binario
- Left wall connector for track profile
- Wandhalter links für Laufschiene

e▶ B.87

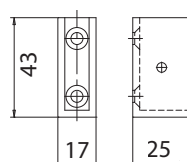

xfb-065



BX-2000-C08 DX

- Attacco a vetro destro per binario
- Right glass connector for track profile
- Glashalter rechts für Laufschiene

e▶ B.88

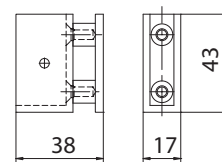

xfb-065



BX-2000-C08 SX

- Attacco a vetro sinistro per binario
- Left glass connector for track profile
- Glashalter links für Laufschiene

e▶ B.89

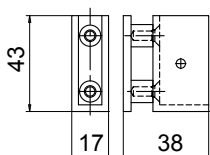

xfb-065



BX-2000-C02

- Stopper

e▶ B.90

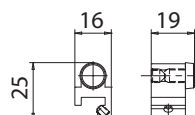

xfb-065



BX-2000-C10

- Connettore ad angolo per binario
- Corner connector for track profile
- Winkelverbinder Laufschiene

e▶ B.91

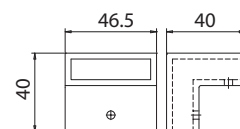

xfb-065



SCORREVOLI

BX-01



SCORREVOLI

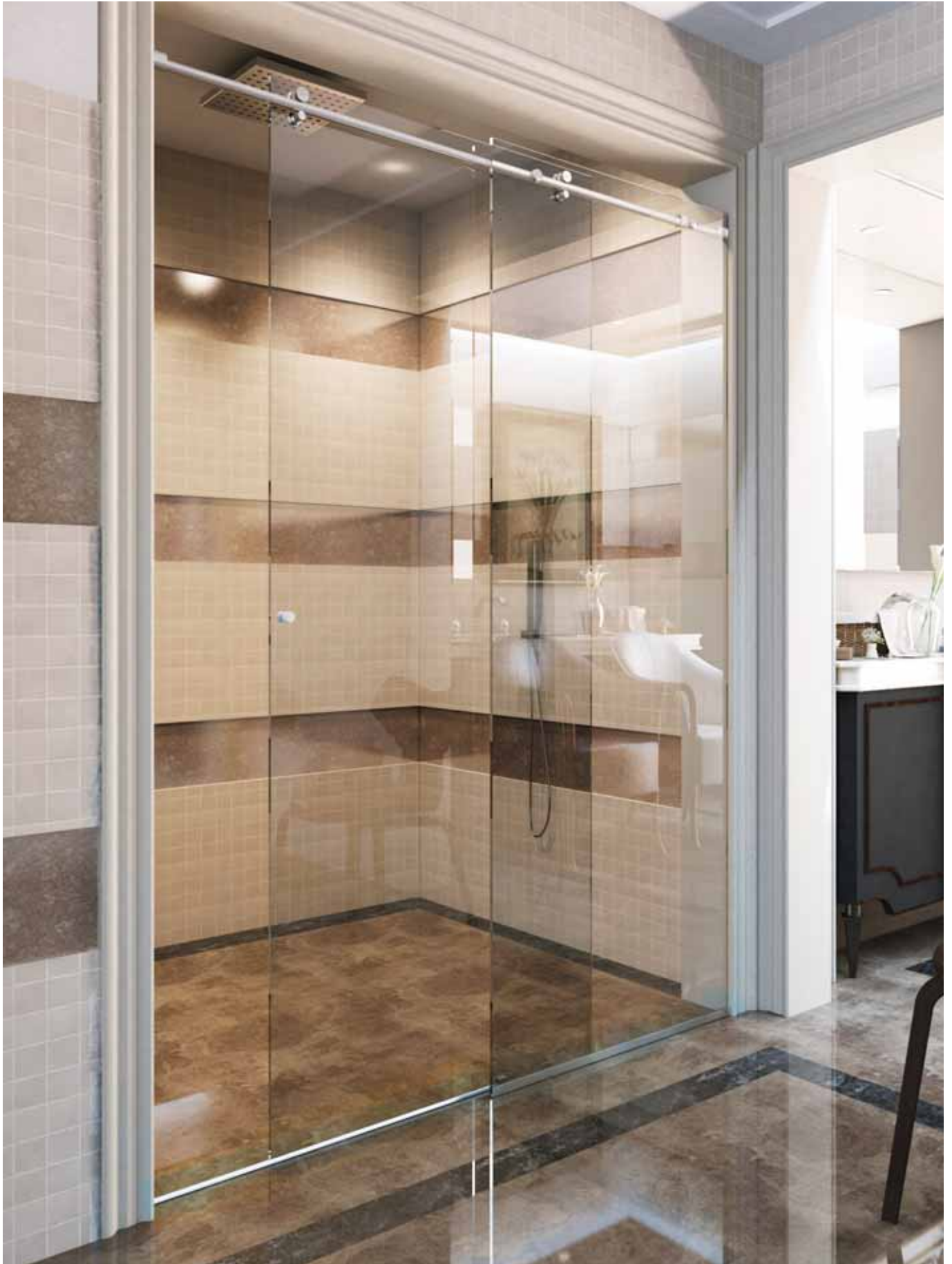

- Sistema scorrevole per box doccia disponibile per versioni in angolo, lineare e in nicchia.
Materiale: acciaio inox lucido.
Possibilità di regolazione tramite ruota ± 2 mm.
- Sliding system for showers box, available for corners, single doors or for niche installations.
Material: polished stainless steel.
Adjustment of carrying wheels ± 2 mm.
- Schiebetürsystem für Duschkabinen, lieferbar für Eck-, Linear und Nischenduschen.
Material: Edelstahl poliert.
Höheneinstellung der Räder ± 2 mm.



SCORREVOLI

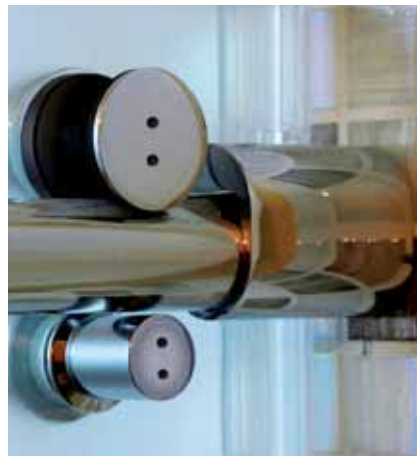
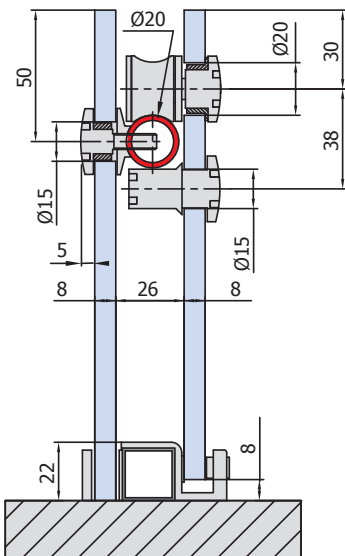

 SET 1 [e► B.118](#)

 SET 2 [e► B.119](#)

 SET 3 [e► B.120](#)

 SET 4 [e► B.121](#)

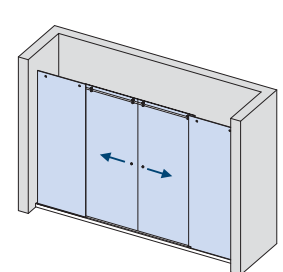
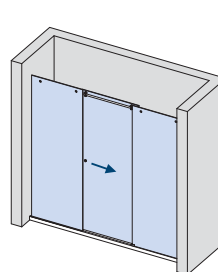
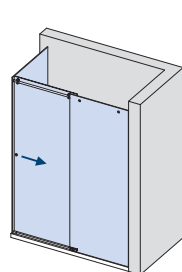
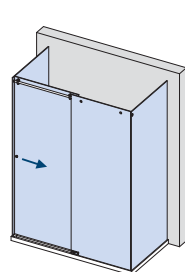
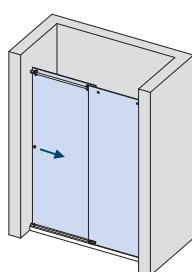
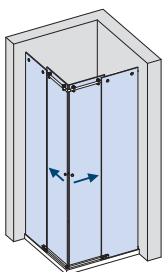
 SET 5 [e► B.122](#)

 SET 6 [e► B.123](#)

BX-01 SET 1

DOCCIA IN ANGOLO / CORNER SHOWER / ECKDUSCHE

e► B.118

8
350 min
390 max

Fin. / Fin. / Oberf.

IL
Acciaio inox lucido
Polished stainless steel
Edelstahl poliert

COMPONENTI / COMPONENTS / EINZELTEILE

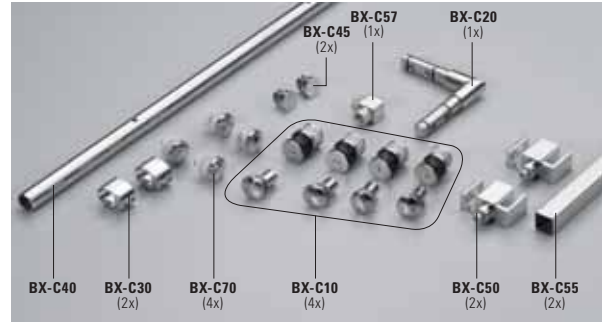
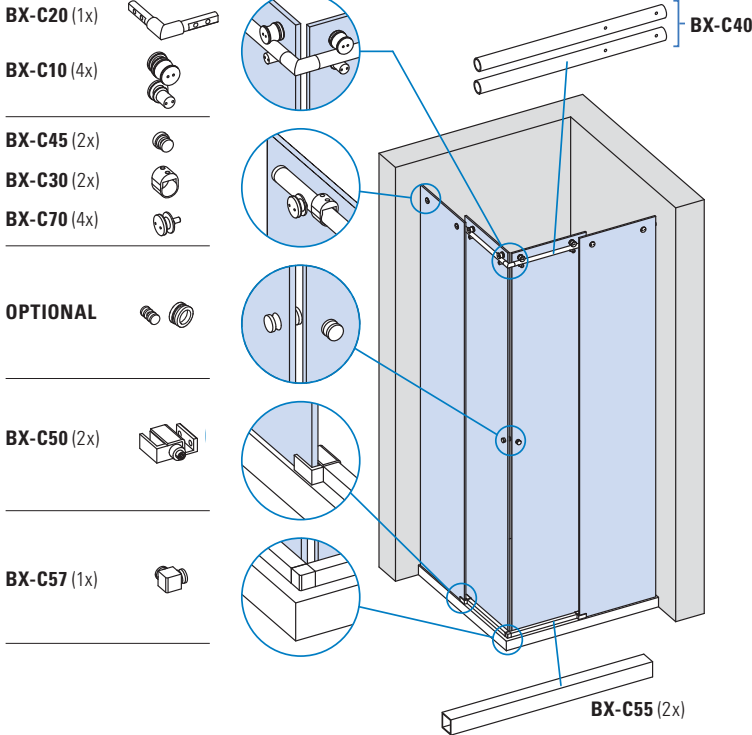

CARATTERISTICHE COMPONENTI /
FEATURES COMPONENTS /
EIGENSCHAFTEN EINZELTEILE ► 70

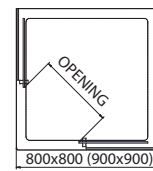
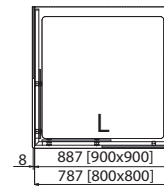

xme208

BX-01 SET 2

DOCCIA IN NICCHIA / NICHE SHOWER / NISCHENDUSCHE

e► B.119

8
550 min
800 max

Fin. / Fin. / Oberf.

IL
Acciaio inox lucido
Polished stainless steel
Edelstahl poliert

COMPONENTI / COMPONENTS / EINZELTEILE

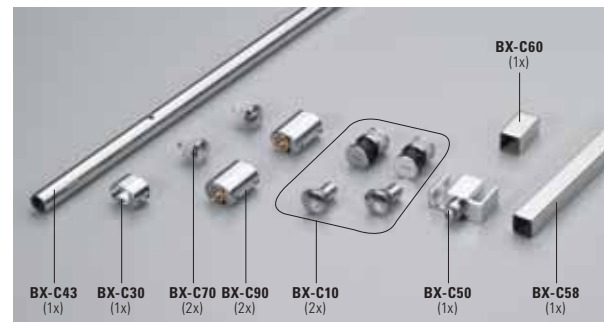
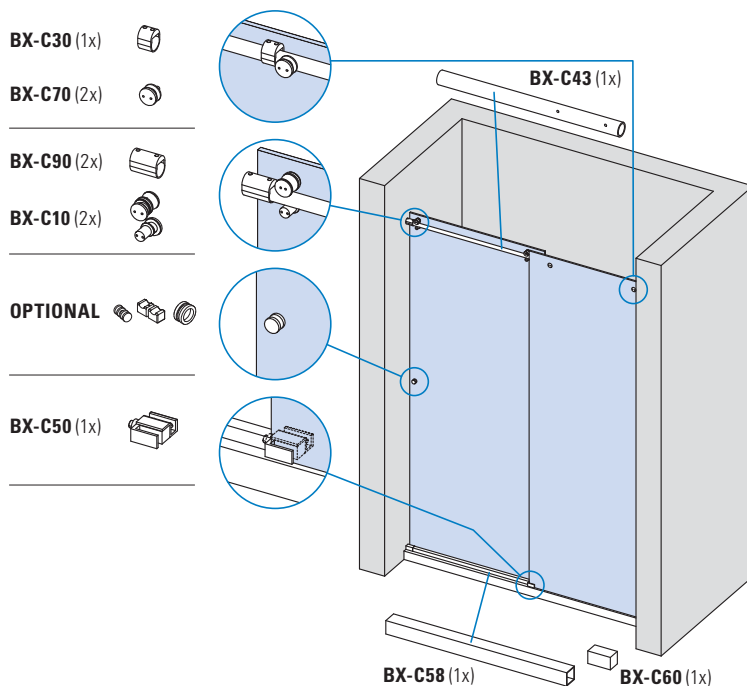

CARATTERISTICHE COMPONENTI /
FEATURES COMPONENTS /
EIGENSCHAFTEN EINZELTEILE ► 70

xme210

SCORREVOLI

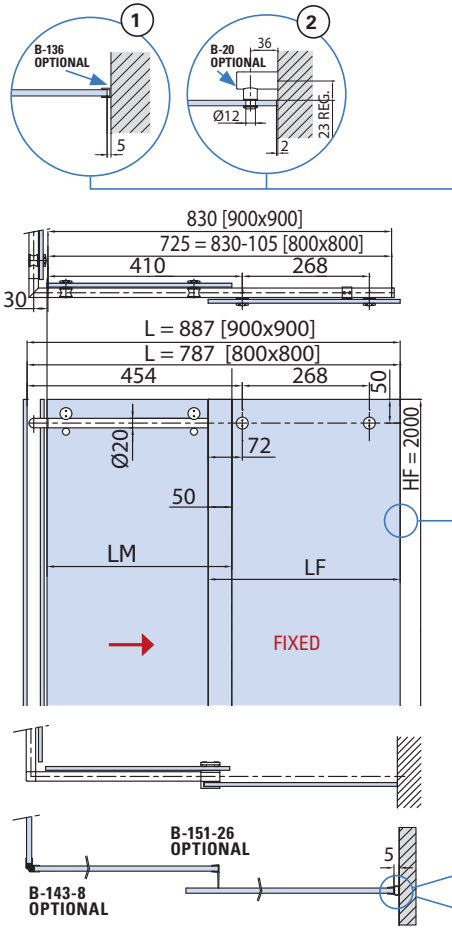
LAVORAZIONE VETRO / GLASS PREPARATION / GLASBEARBEITUNG

CALCOLO VETRO / CALCULATION GLASS / GLASBERECHNUNG

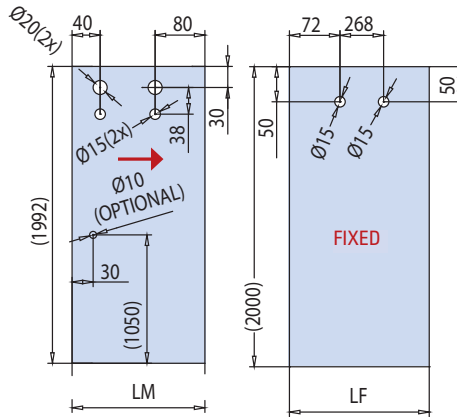
$L = 800 \times 800 \text{ mm} (900 \times 900 \text{ mm})$
 $LM = (L - 5) / 2 (350 \text{ min} / 390 \text{ max})$
 $LF = [(L - 5) / 2] \cdot * (1) / * (2)$ (aria variabile / clearance / Spaltmaß)
 $HM = H - 8 = 1992 \text{ mm}$
 $HF = H = 2000 \text{ mm}$



xme208a

SET 1 / SET 2
DA TAGLIARE / ADJUST THE LENGTH / BELIEBIG KÜRZBAR ✂

- Forature per fissaggio vetro fisso.
- Holes in profile for fixed glass.
- Bohrungen im Profil für Seitenteil Befestigung.

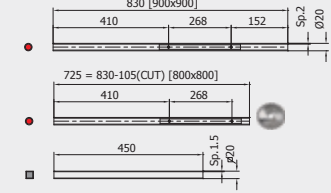
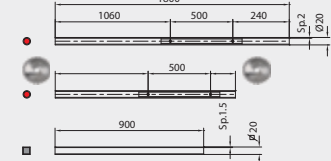
SET 1

SET 2

- Profilo a terra ingresso doccia incluso.
- Floor profile shower entry included.
- Bodenprofil im Einstiegsbereich.

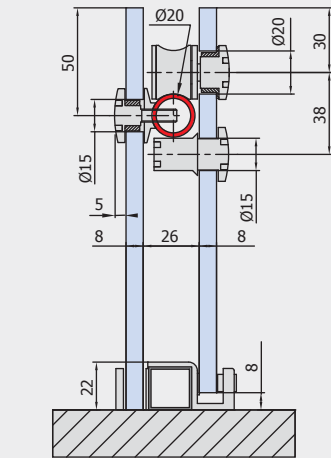
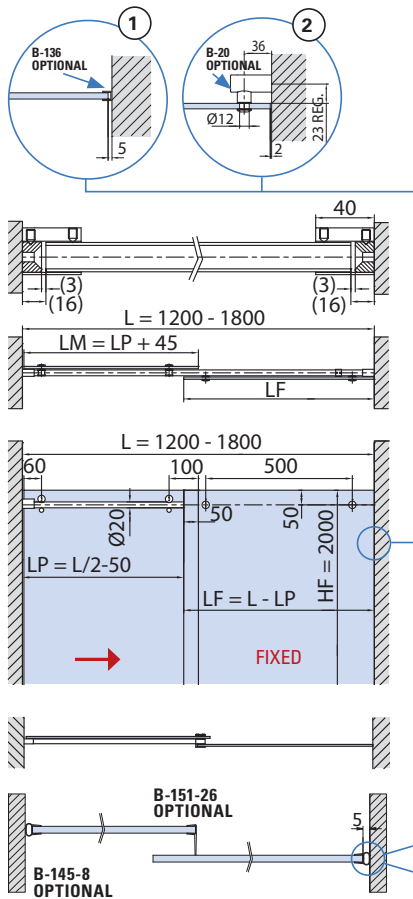
- Regolazione ruota $\pm 2 \text{ mm}$.
- Adjustment $\pm 2 \text{ mm}$.
- Verstellung $\pm 2 \text{ mm}$.

 $HM = H - 8$
 $HF = H$
OPTIONAL

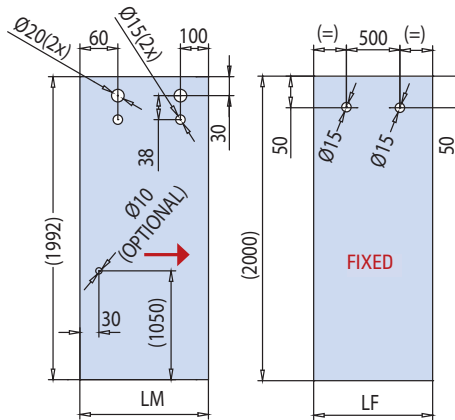
CALCOLO VETRO / CALCULATION GLASS / GLASBERECHNUNG

$L = 1200 \text{ mm} \rightarrow 1650 \text{ mm}$
 $LP = L / 2 - 50$
 $LM = LP + 45$
 $LF = L - LP \cdot * (1) / * (2)$ (aria variabile / clearance / Spaltmaß)
 $HM = H - 8 = 1992 \text{ mm}$
 $HF = H = 2000 \text{ mm}$



xme210a

L Piatto Shower tray Duschtaße	LM Larghezza vetro mobile Sliding glass width Schiebeflügel Breite	LF Larghezza vetro fisso Side fixed glass width Seitenteil Breite	HM Altezza vetro mobile Sliding glass height Schiebeflügel Höhe	HF Altezza vetro fisso Side fixed glass height Seitenteil Höhe	H Altezza doccia Shower height Duschkabine Höhe
--	--	---	---	--	---

BX-01 SET 3

DOCCIA A U / U SHOWER / U DUSCHE

e▶ B.120

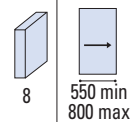

Fin. / Fin. / Oberf.

IL
Acciaio inox lucido
Polished stainless steel
Edelstahl poliert

COMPONENTI / COMPONENTS / EINZELTEILE

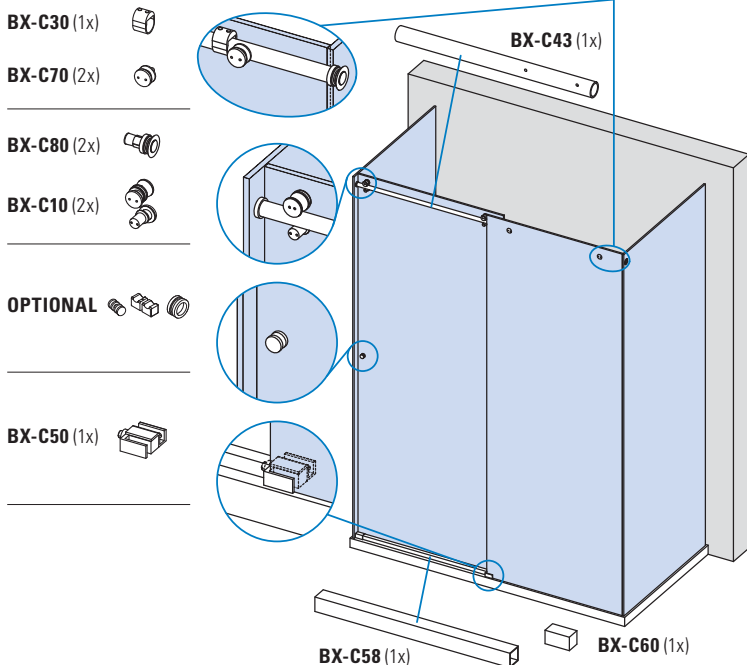

CARATTERISTICHE COMPONENTI / FEATURES COMPONENTS / EIGENSCHAFTEN EINZELTEILE ▶ 70

CALCOLO VETRO / CALCULATION GLASS / GLASBERECHNUNG

$L = 1200 \text{ mm} \rightarrow 1650 \text{ mm}$
 $L1 = L - 5 \times 2$
 $L2 = L1 - 2 \times \text{Sp. vetro} / \text{glass thickness} / \text{glasdicke}$
 $LM = LP + 45$
 $LF = (L2 - LP) - * \textcircled{1} / * \textcircled{2}$ (aria variabile / clearance / Spaltmaß)
 X = calcolare / calculate / berechnen
 X = vedi $\textcircled{1} \textcircled{2}$ / see $\textcircled{1} \textcircled{2}$ / siehe $\textcircled{1} \textcircled{2}$
 $HM = H - 8 = 1992 \text{ mm}$
 $HF = H - 2000 \text{ mm}$
 $HFL = H - 2000 \text{ mm}$

xme209

BX-01 SET 4

DOCCIA CON SPALLA IN VETRO / CORNER SHOWER WITH 2 FIXED PANEL / ECKDUSCHE MIT 2 FESTSTEHENDEN GLASTAFELN

e▶ B.121

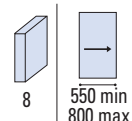

Fin. / Fin. / Oberf.

IL
Acciaio inox lucido
Polished stainless steel
Edelstahl poliert

COMPONENTI / COMPONENTS / EINZELTEILE

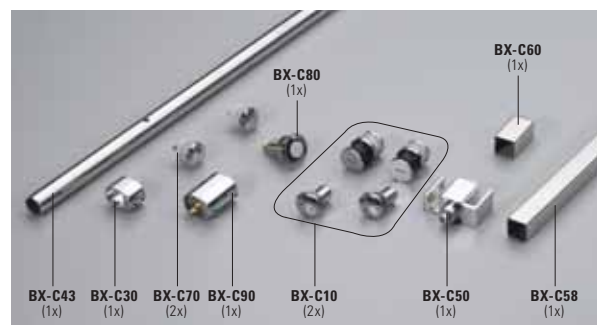
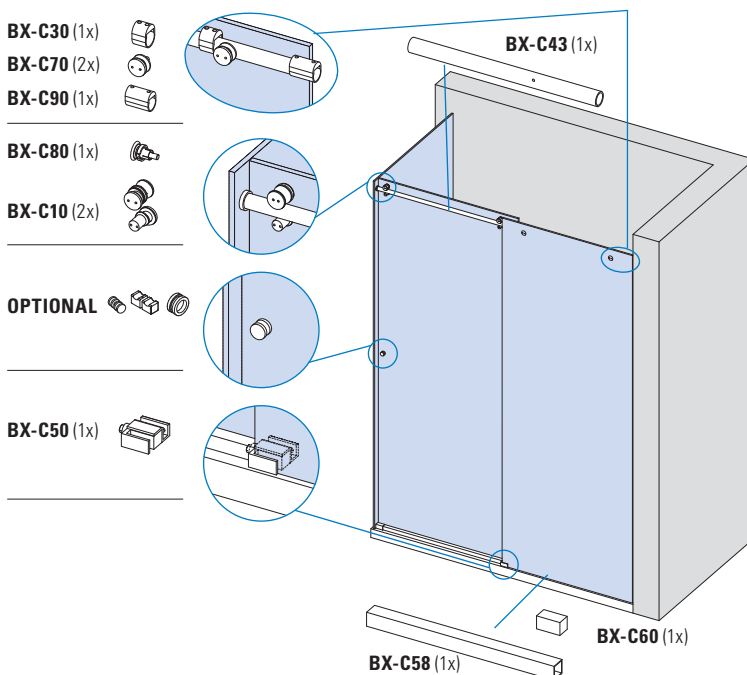

CARATTERISTICHE COMPONENTI / FEATURES COMPONENTS / EIGENSCHAFTEN EINZELTEILE ▶ 70

CALCOLO VETRO / CALCULATION GLASS / GLASBERECHNUNG

$L = 1200 \text{ mm} \rightarrow 1650 \text{ mm}$
 $L1 = L - 5$
 $L2 = L1 - \text{Sp. vetro} / \text{glass thickness} / \text{glasdicke}$
 $LP = L2 / 2 - 50$
 $LM = LP + 45$
 $LF = (L2 - LP) - \textcircled{1} \textcircled{2}$ (aria variabile / clearance / Spaltmaß)
 X = calcolare / calculate / berechnen
 X = vedi $\textcircled{1} \textcircled{2}$ / see $\textcircled{1} \textcircled{2}$ / siehe $\textcircled{1} \textcircled{2}$
 $HM = H - 8 = 1992 \text{ mm}$
 $HF = H - 2000 \text{ mm}$
 $HFL = H - 2000 \text{ mm}$

xme211

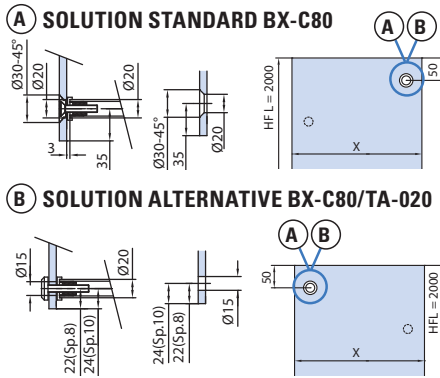
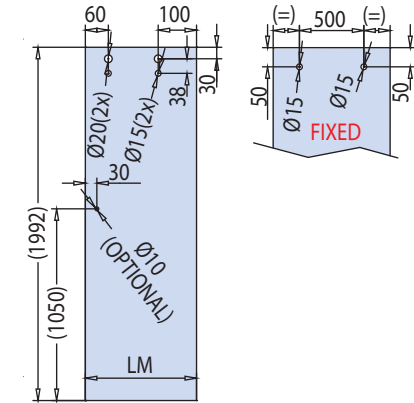
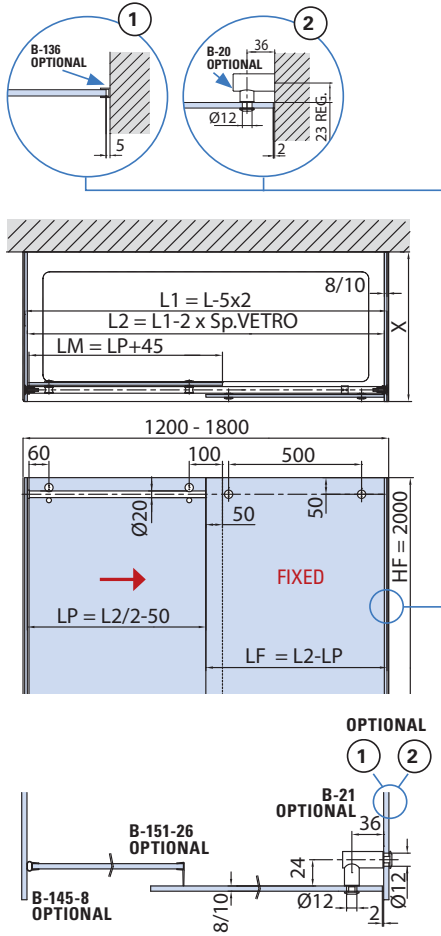
LAVORAZIONE VETRO / GLASS PREPARATION / GLASBEARBEITUNG

xme209a

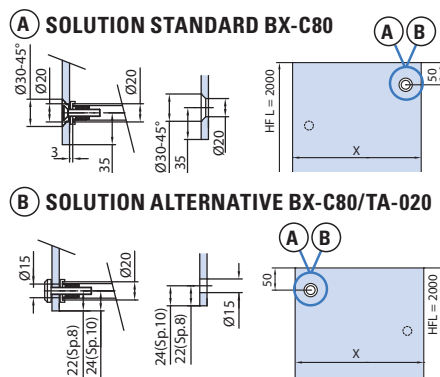
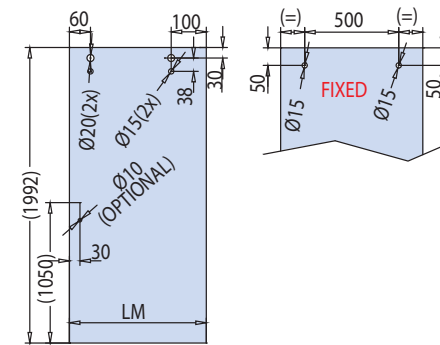
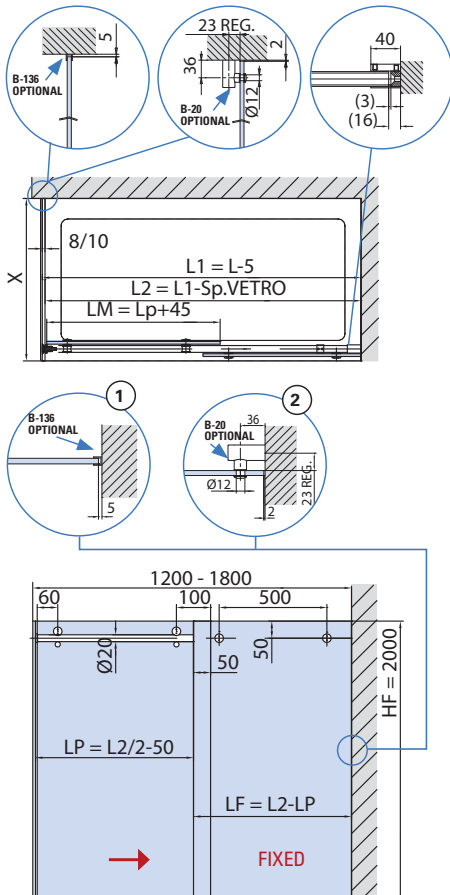

xme208 / xme209 / xme211

SET 3 / SET 4
DA TAGLIARE / ADJUST THE LENGTH / BELIEBIG KÜRZBAR

- Forature per fissaggio vetro fisso.
- Holes in profile for fixed glass.
- Bohrungen im Profil für Seitenteil Befestigung.

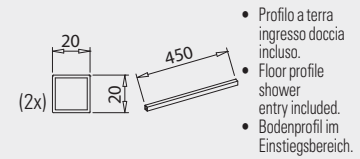
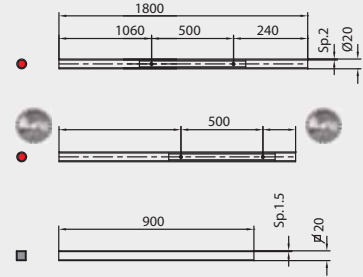

- Regolazione ruota ± 2 mm.
- Adjustment ± 2 mm.
- Verstellung ± 2 mm.

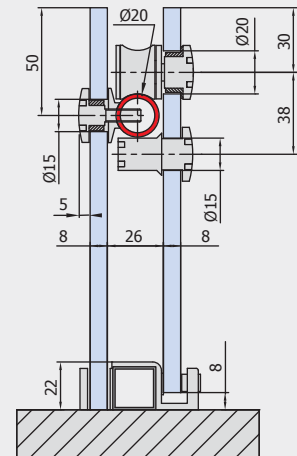
 HM = H - 8
 HF = H

OPTIONAL

L	LP	LM	LF	HM	HF	H	HFL
Piatto Shower tray Duschtaße	Passaggio luce Clear opening width Lichte Durchgangsbreite	Larghezza vetro mobile Sliding glass width Schiebeflügel Breite	Larghezza vetro fisso Side fixed glass width Seitenteil Breite	Altezza vetro mobile Sliding glass height Schiebeflügel Höhe	Altezza vetro fisso Side fixed glass height Seitenteil Höhe	Altezza doccia Shower height Duschcabine Höhe	Altezza vetro fisso laterale Side fixed glass height Seitenteil (seitlich) Höhe

BX-01 SET 5

DOCCIA CON 2 VETRI FISSI E UNO MOBILE / SHOWER WITH 2 FIXED PANELS AND 1 SLIDING PANEL / DUSCHKABIN MIT 2 SEITENTEILEN UND 1 SCHIEBETÜR

e▶ B.122

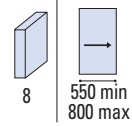

Fin. / Fin. / Oberf.

IL
Acciaio inox lucido
Polished stainless steel
Edelstahl poliert

COMPONENTI / COMPONENTS / EINZELTEILE

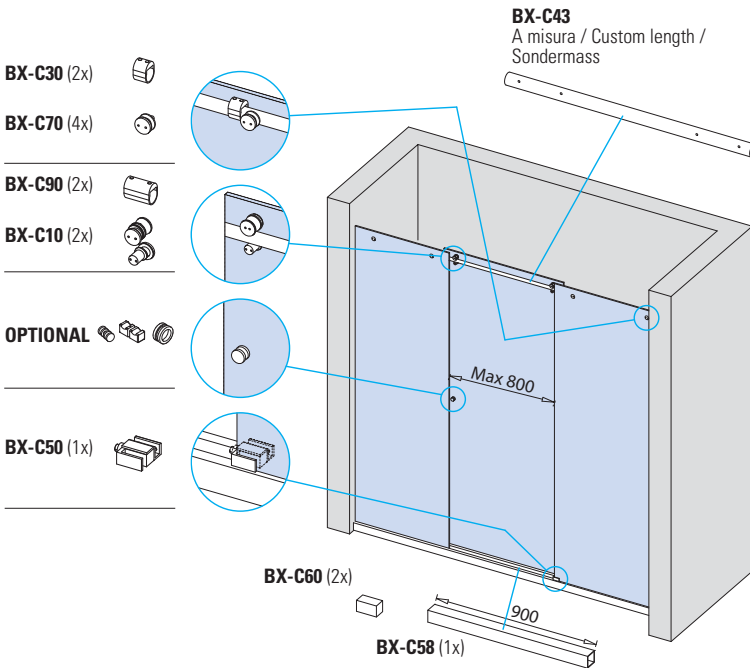

CARATTERISTICHE COMPONENTI / FEATURES COMPONENTS / EIGENSCHAFTEN EINZELTEILE ▶ 70

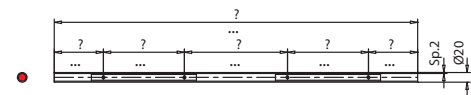

- Obbligatorio comunicare foratura barra.
- Mandatory to inform drilling of the bar.
- Obligatorisch Bohrungen in der Stange angeben.

xmc035

BX-01 SET 6

DOCCIA CON 2 VETRI FISSI E 2 MOBILI / SHOWER WITH 2 FIXED PANELS AND 2 SLIDING PANELS / DUSCHKABIN MIT 2 SEITENTEILEN UND 2 SCHIEBETÜREN

e▶ B.123

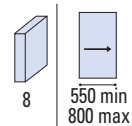

Fin. / Fin. / Oberf.

IL
Acciaio inox lucido
Polished stainless steel
Edelstahl poliert

COMPONENTI / COMPONENTS / EINZELTEILE

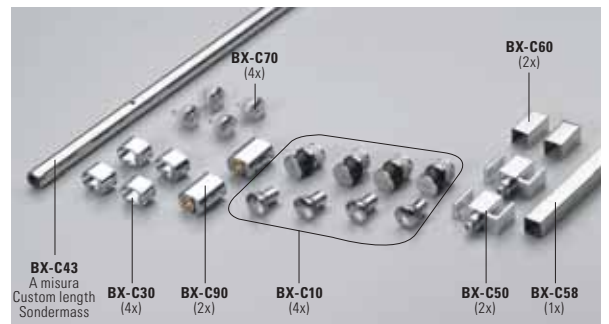
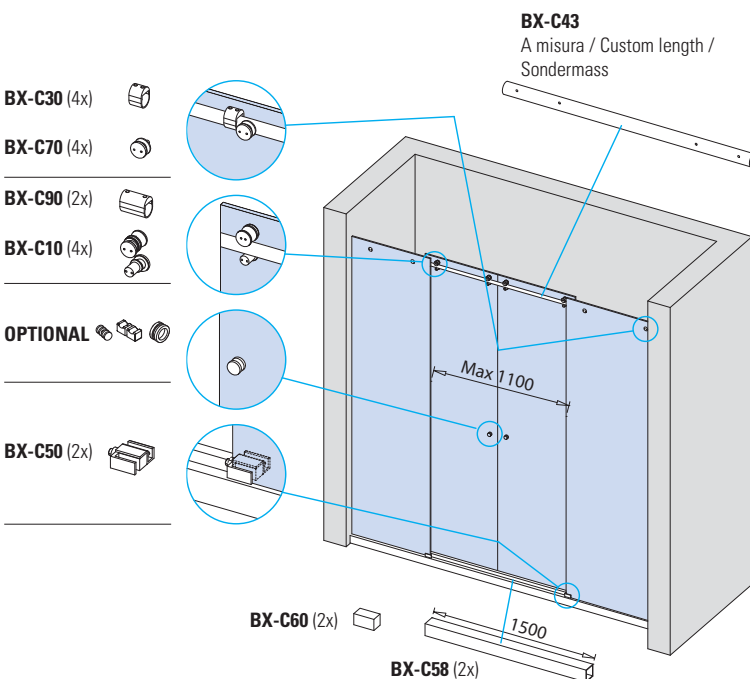

CARATTERISTICHE COMPONENTI / FEATURES COMPONENTS / EIGENSCHAFTEN EINZELTEILE ▶ 70

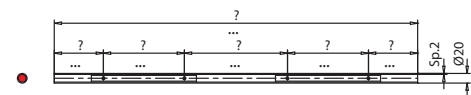

- Obbligatorio comunicare foratura barra.
- Mandatory to inform drilling of the bar.
- Obligatorisch Bohrungen in der Stange angeben.

xmc035b1

SCORREVOLI

LAVORAZIONE VETRO / GLASS PREPARATION / GLASBEARBEITUNG

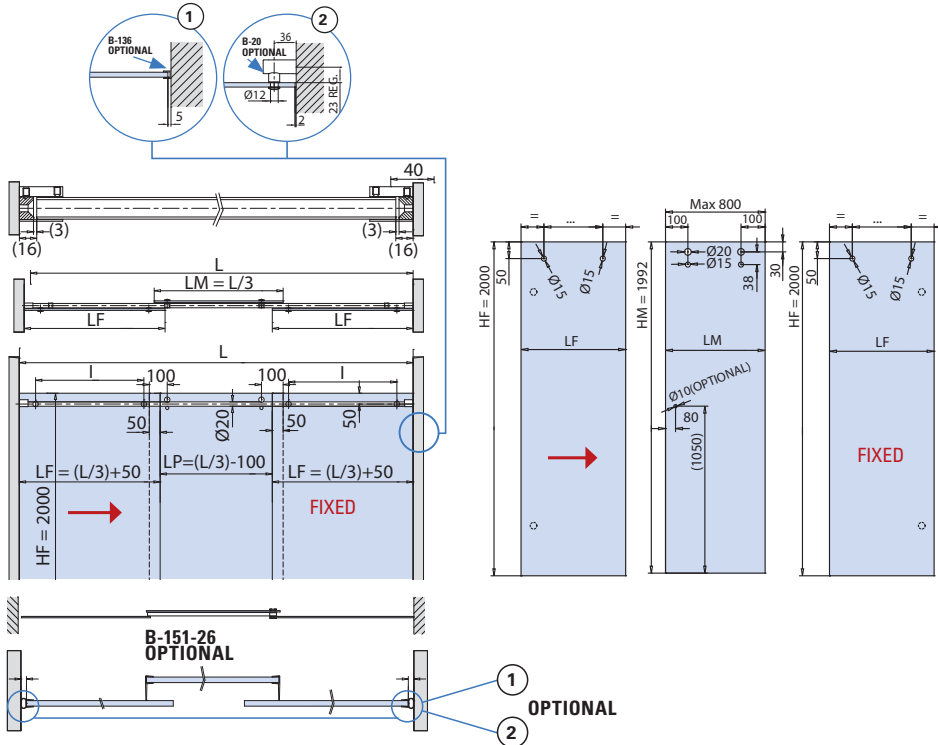

CALCOLO VETRO / CALCULATION GLASS / GLASBERECHNUNG

L = misura cliente / customer indication / kunden zeichnung
 LP = $L / 3 - 100$
 LM = $L / 3$
 LF = $L / 3 + 50 - * (1) / * (2)$ (aria variabile / clearance / Spaltmaß)
 HM = $H - 8 = 1992$ mm
 HF = $H = 2000$ mm

xmc035a

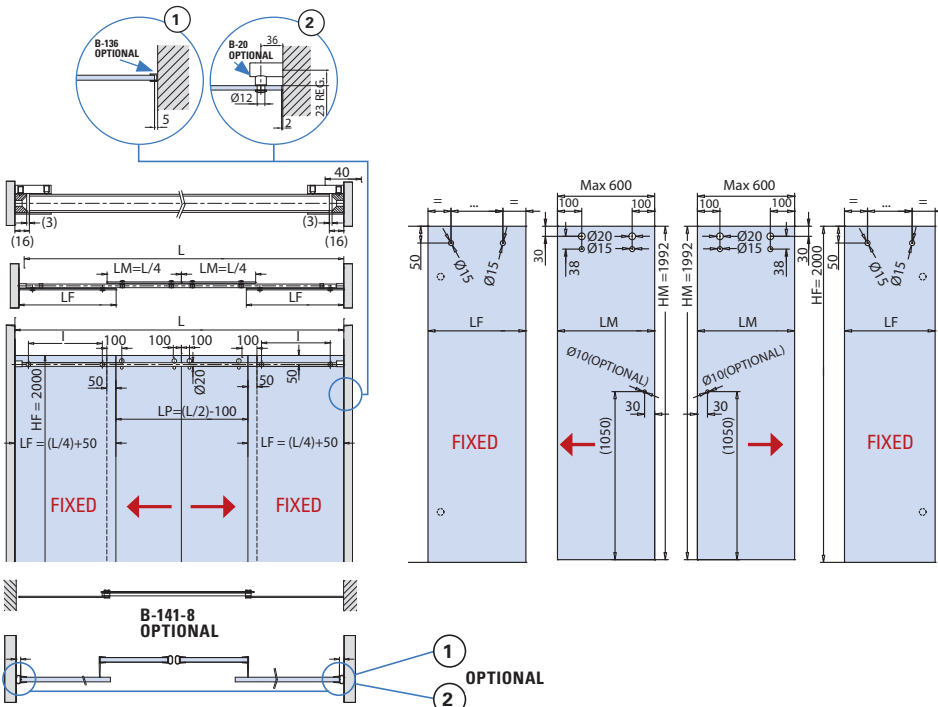

CALCOLO VETRO / CALCULATION GLASS / GLASBERECHNUNG

L = misura cliente / customer indication / kunden zeichnung
 LP = $L / 2 - 100$
 LM = $L / 4$
 LF = $L / 4 + 50 - * (1) / * (2)$ (aria variabile / clearance / Spaltmaß)
 HM = $H - 8 = 1992$ mm
 HF = $H = 2000$ mm

xmc035b2

L	LM	LF	HM	HF	H
Piatto Shower tray Duschtaße	Larghezza vetro mobile Sliding glass width Schiebeflügel Breite	Larghezza vetro fisso Side fixed glass width Seitenteil Breite	Altezza vetro mobile Sliding glass height Schiebeflügel Höhe	Altezza vetro fisso Side fixed glass height Seitenteil Höhe	Altezza doccia Shower height Duschkabine Höhe

SET 5 / SET 6

DA TAGLIARE / ADJUST THE LENGTH / BELIEBIG KÜRZBAR ✂

- Forature per fissaggio vetro fisso.
- Holes in profile for fixed glass.
- Bohrungen im Profil für Seitenteil Befestigung.

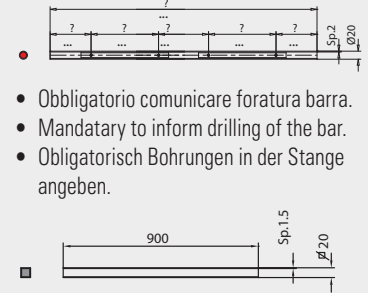

- Obbligatorio comunicare foratura barra.
- Mandatory to inform drilling of the bar.
- Obligatorisch Bohrungen in der Stange angeben.

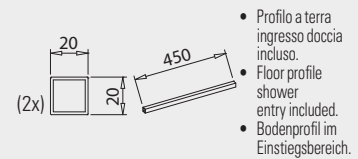

- Regolazione ruota ± 2 mm.
- Adjustment ± 2 mm.
- Verstellung ± 2 mm.

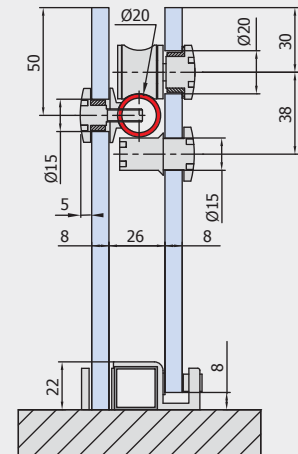

HM = H - 8
 HF = H

OPTIONAL

B-151-26 ▶ 169	B-143-8 ▶ 169
B-136 ▶ 141	BX-PF-02 ▶ 144
MORSETTI ▶ 160	NICCHIE ▶ 175

SCORREVOLI

BX-01

COMPONENTI / COMPONENTS / EINZELTEILE

SCORREVOLI

BX-C43 / BX-C40

- Binario
- Track profile
- Laufschiene

[e▶ B.124](#)

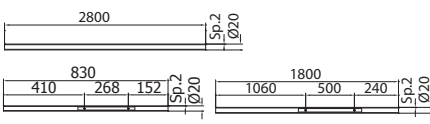
Cod.	Fin./Fin./Oberf.
BX-C43-1800 mm	IL
BX-C43-2800 mm*	IL
BX-C40-830 x 830 mm (2 pcs)	IL

*Senza fori / Without holes / Ohne Bohrungen

BX-C10 [e▶ B.125](#)

- Ruota con perno antigancio
- Roller with anti-jump pin
- Laufrolle und Aushebeschutz



xme382

BX-C70 [e▶ B.126](#)

- Punto di fissaggio vetro fisso al binario
- Fixing point for fixed glass and track profile
- Punkthalter für Fixierung des Festteils auf Laufschiene

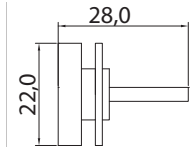
xme382

BX-C90 [e▶ B.127](#)

- Attacco a parete per binario
- Wall connector for track profile
- Wandhalter für Laufschiene



xme382

BX-C30 [e▶ B.128](#)

- Stopper



xme382

BX-C20 [e▶ B.129](#)

- Connettore ad angolo per binario
- Corner connector for track profile
- Winkelverbinder Laufschiene

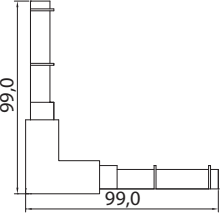
xme382

BX-C80 [e▶ B.130](#)

- Attacco a vetro per binario
- Glass connector for track profile
- Glashalter für Laufschiene



xme382

BX-C50 [e▶ B.131](#)

- Guida a pavimento
- Floor guide
- Bodenführung





xme383

BX-C58 / BX-C55

- Profilo a terra
- Floor profile
- Bodenprofil

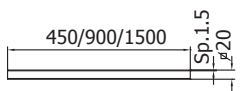
[e▶ B.132](#)

Cod.	Fin./Fin./Oberf.
BX-C58-1500 mm	IL
BX-C58-900 mm	IL
BX-C55-450 mm	IL

bx-c58-bx-c55

BX-C60

- Coperchietto finale per profilo a terra BX-C55 / BX-C58
- Endcap for floor profiles BX-C55 / BX-C58
- Endkappe für Bodenprofile BX-C55 / BX-C58.

[e▶ B.133](#)

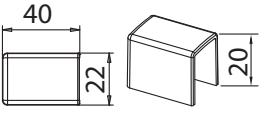
xla307

BX-C57

- Connettore ad angolo per profilo a terra
- Corner connector for floor profile
- Winkelverbinder für Bodenprofil

[e▶ B.134](#)



xme383

BX-C45 [e▶ B.135](#)

- Tappo finale per binario
- Endcap for track profile
- Endkappe der Laufschiene

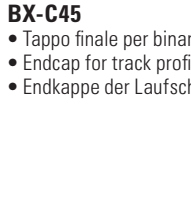
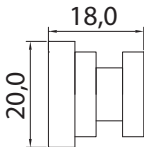
xme382



SCORREVOLI

BX-02



SCORREVOLI



- Sistema scorrevole per box doccia disponibile per versioni in angolo, lineare e in nicchia.
Materiale: acciaio inox lucido.
- Sliding system for showers box, available for corners, single doors or for niche installations.
Material: polished stainless steel.
- Schiebetürsystem für Duschkabinen, lieferbar für Eck-, Linear und Nischenduschen.
Material: Edelstahl poliert.

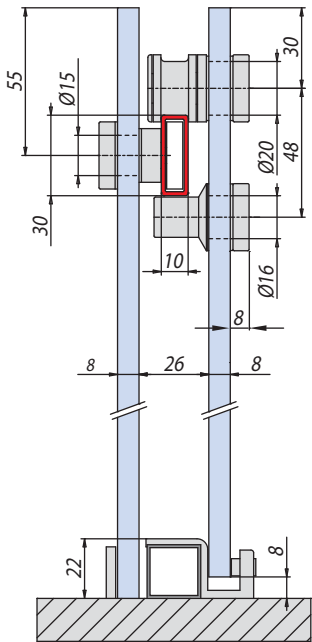

SCORREVOLI

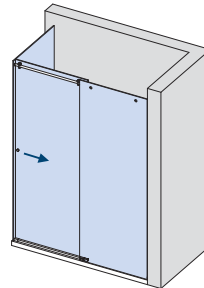
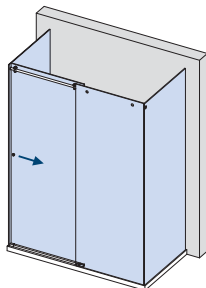
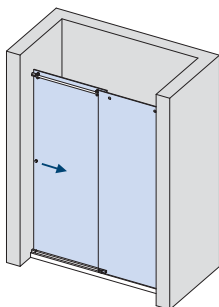
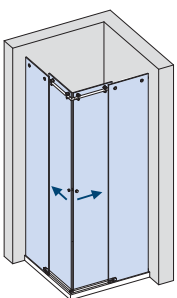
SET 1 [e► B.136](#)
SET 2 [e► B.137](#)
SET 3 [e► B.138](#)
SET 4 [e► B.139](#)

BX-02 SET 1

DOCCIA IN ANGOLO / CORNER SHOWER / ECKDUSCHE

e► B.136

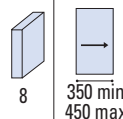

Fin. / Fin. / Oberf.

CR
Cromo lucido
Polished chrome
Chrom glänzend

COMPONENTI / COMPONENTS / EINZELTEILE

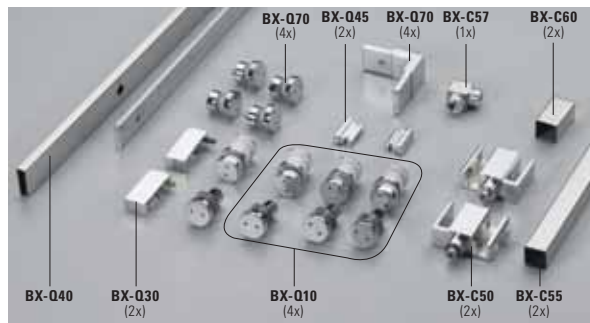
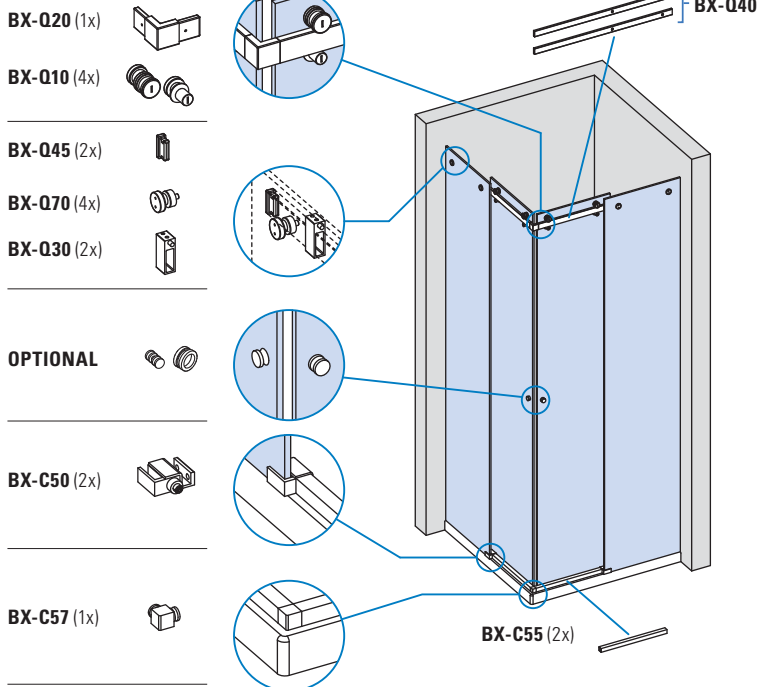

CARATTERISTICHE COMPONENTI /
FEATURES COMPONENTS /
EIGENSCHAFTEN EINZELTEILE ► 78

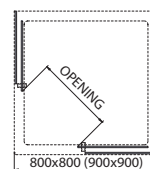
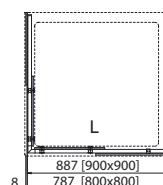

xme328

BX-02 SET 2

DOCCIA IN NICCHIA / NICHE SHOWER / NISCHENDUSCHE

e► B.137

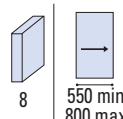

Fin. / Fin. / Oberf.

CR
Cromo lucido
Polished chrome
Chrom glänzend

COMPONENTI / COMPONENTS / EINZELTEILE

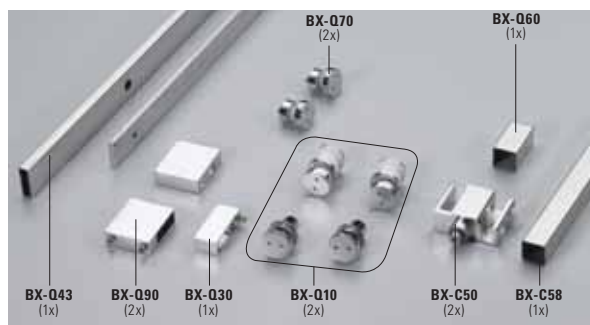
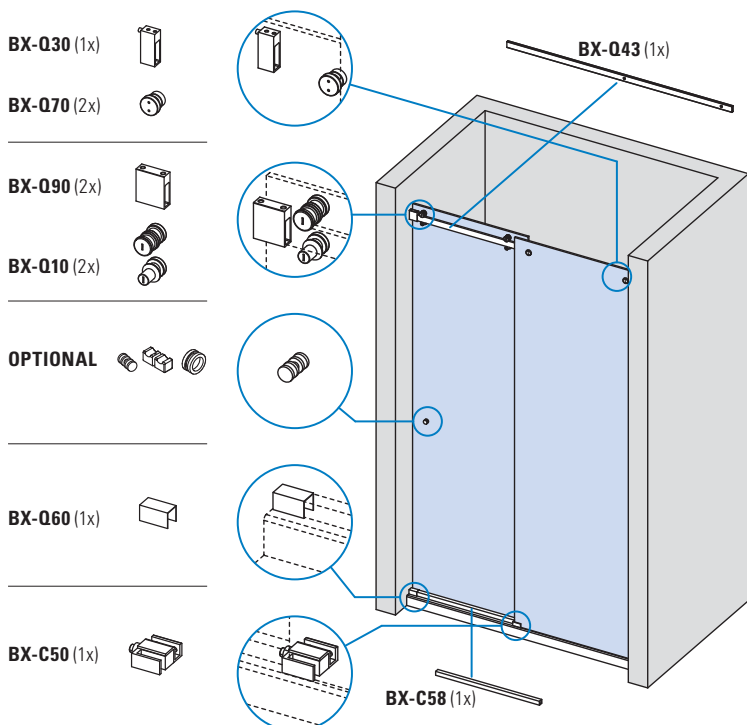

CARATTERISTICHE COMPONENTI /
FEATURES COMPONENTS /
EIGENSCHAFTEN EINZELTEILE ► 78

xla329

SCORREVOLI

LAVORAZIONE VETRO / GLASS PREPARATION / GLASBEARBEITUNG

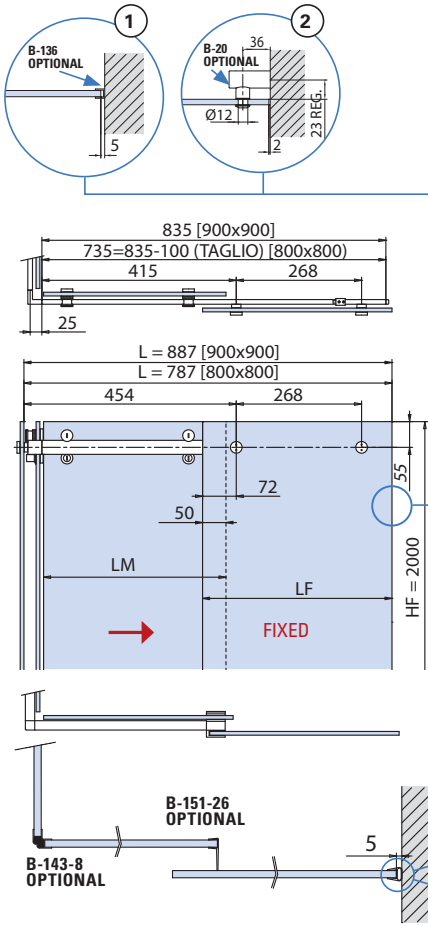

CALCOLO VETRO / CALCULATION GLASS / GLASBERECHNUNG

L = 800 x 800 mm (900 x 900 mm)
 $LM = (L - 5) / 2$
 $LF = [(L - 5) / 2] - * (1) / * (2)$ (aria variabile / clearance / Spaltmaß)
 $HM = H - 8 = 1992$ mm
 $HF = H = 2000$ mm

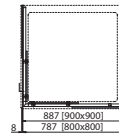
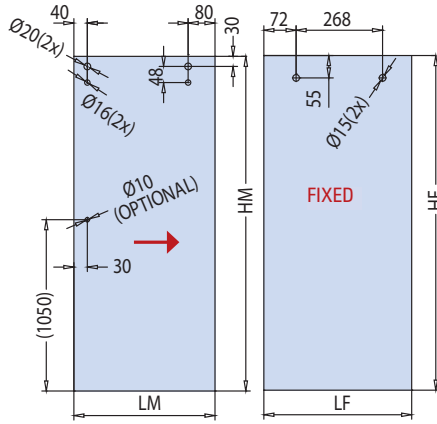

xla328b

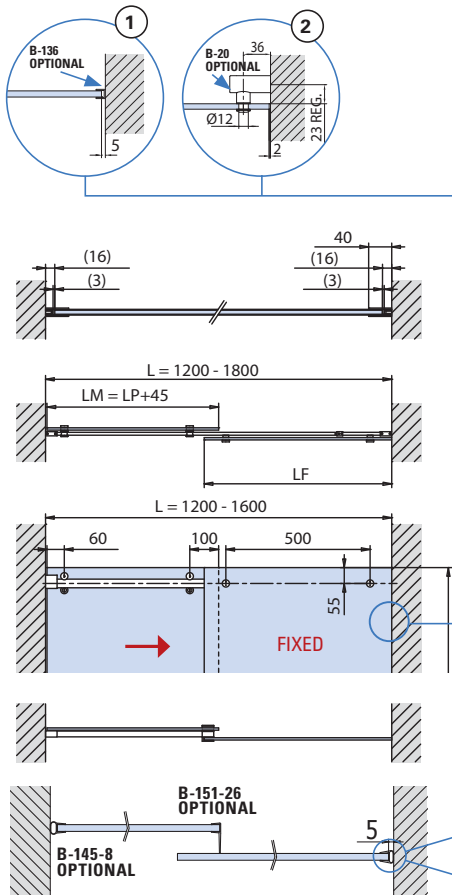

CALCOLO VETRO / CALCULATION GLASS / GLASBERECHNUNG

L = 1200 mm → 1800 mm
 $LP = L / 2 - 50$
 $LM = LP + 45$
 $LF = L - LP - * (1) / * (2)$ (aria variabile / clearance / Spaltmaß)
 $HM = H - 8 = 1992$ mm
 $HF = H = 2000$ mm

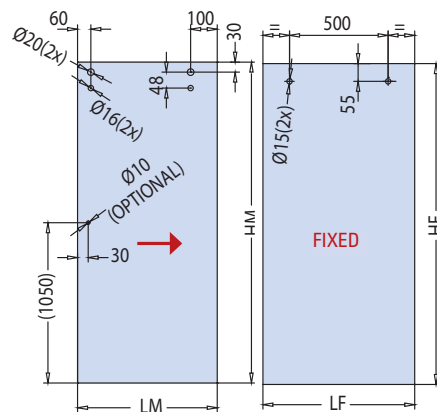

xla329b

SET 1 / SET 2

DA TAGLIARE / ADJUST THE LENGTH / BELIEBIG KÜRZBAR ✂

- Forature per fissaggio vetro fisso.
- Holes in profile for fixed glass.
- Bohrungen im Profil für Seitenteil Befestigung.

SET 1

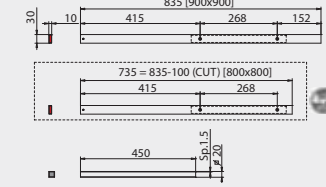

SET 2

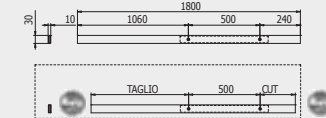

- Profilo a terra ingresso doccia incluso.
- Floor profile shower entry included.
- Bodenprofil im Einstiegsbereich.

- Regolazione ruota ± 2 mm.
- Adjustment ± 2 mm.
- Verstellung ± 2 mm.

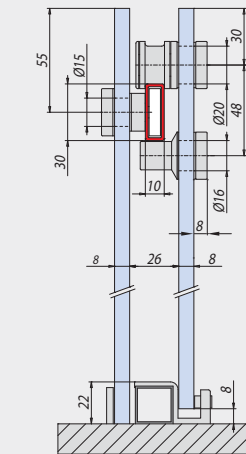

HM = H - 8
 HF = H

OPTIONAL



L Piatto Shower tray Duschtaße	LM Larghezza vetro mobile Sliding glass width Schiebeflügel Breite	LF Larghezza vetro fisso Side fixed glass width Seitenteil Breite	HM Altezza vetro mobile Sliding glass height Schiebeflügel Höhe	HF Altezza vetro fisso Side fixed glass height Seitenteil Höhe	H Altezza doccia Shower height Duschkabine Höhe
--	--	---	---	--	---

SCORREVOLI

BX-02 SET 3

DOCCIA A U / U SHOWER / U DUSCHE

e▶ B.138

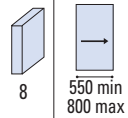

Fin. / Fin. / Oberf.

CR
Cromo lucido
Polished chrome
Chrom glänzend

COMPONENTI / COMPONENTS / EINZELTEILE

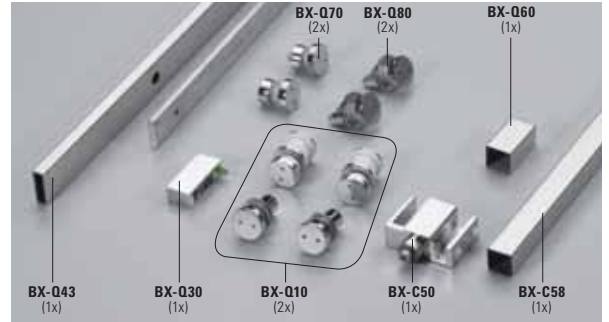
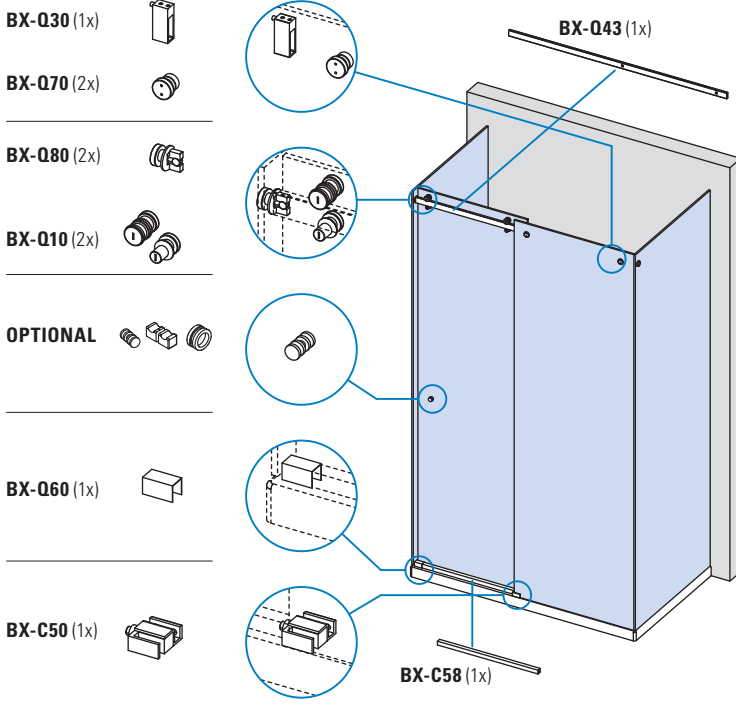

CARATTERISTICHE COMPONENTI /
FEATURES COMPONENTS /
EIGENSCHAFTEN EINZELTEILE ▶ 78

xla330

BX-02 SET 4

DOCCIA CON SPALLA IN VETRO / CORNER SHOWER WITH 2 FIXED PANEL / ECKDUSCHE MIT 2 FESTSTEHENDEN GLASTAFELN

e▶ B.139

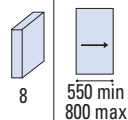

Fin. / Fin. / Oberf.

CR
Cromo lucido
Polished chrome
Chrom glänzend

COMPONENTI / COMPONENTS / EINZELTEILE

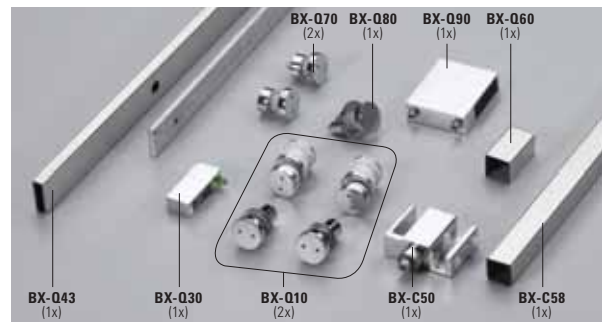
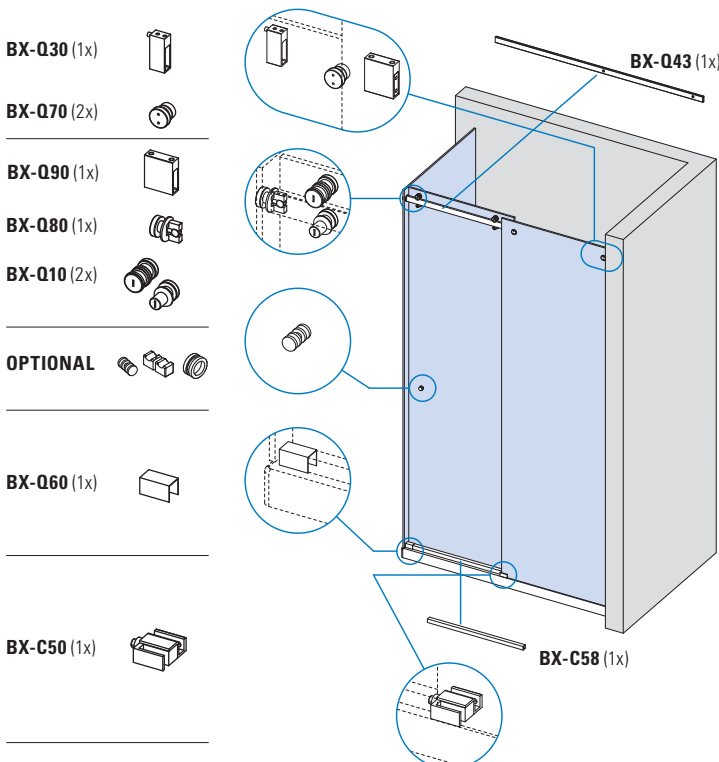

CARATTERISTICHE COMPONENTI /
FEATURES COMPONENTS /
EIGENSCHAFTEN EINZELTEILE ▶ 78

xla331

SCORREVOLI

LAVORAZIONE VETRO / GLASS PREPARATION / GLASBEARBEITUNG

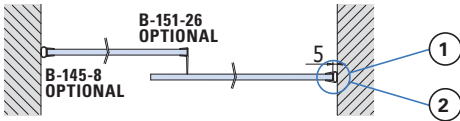
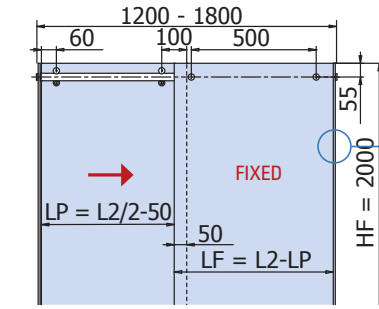
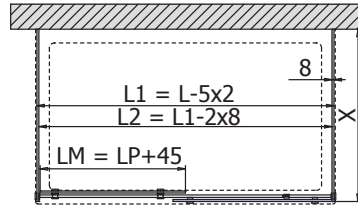
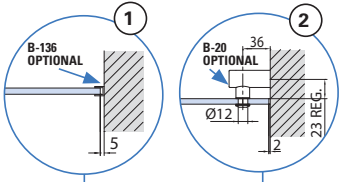

CALCULATION GLASS / CÁLCULO VIDRIO /
CALCUL DU VERRE

$L = 1200 \text{ mm} \rightarrow 1800 \text{ mm}$
 $L1 = L - 5 \times 2$
 $L2 = L1 - 2 \times 8$
 $LM = LP + 45$
 $LF = (L2 - LP) - * \textcircled{1} / * \textcircled{2}$ (aria variabile /
clearance / Spaltmaß)
X = calcolare / calculate / berechnen
X = vedi $\textcircled{1} \textcircled{2}$ / see $\textcircled{1} \textcircled{2}$ / siehe $\textcircled{1} \textcircled{2}$
 $HM = H - 8 = 1992 \text{ mm}$
 $HFL = H - 2000 \text{ mm}$

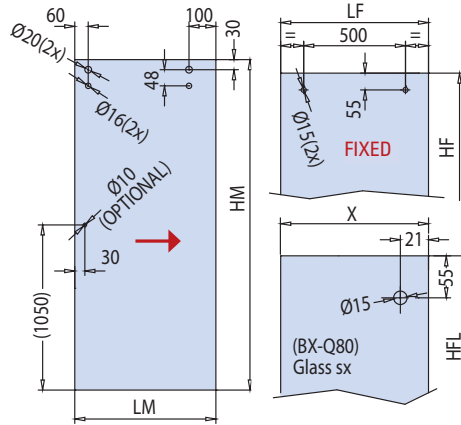

SET 3 / SET 4

DA TAGLIARE / ADJUST THE LENGTH /
BELIEBIG KÜRZBAR ✂

- Forature per fissaggio vetro fisso.
- Holes in profile for fixed glass.
- Bohrungen im Profil für Seitenteil Befestigung.

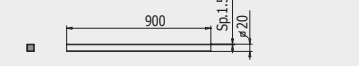
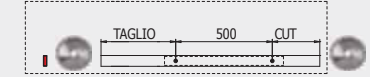
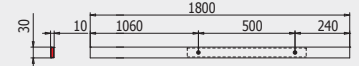

- Profilo a terra ingresso doccia incluso.
- Floor profile shower entry included.
- Bodenprofil im Einstiegsbereich.

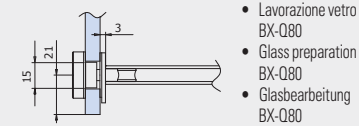

- Lavorazione vetro BX-Q80
- Glass preparation BX-Q80
- Glasbearbeitung BX-Q80

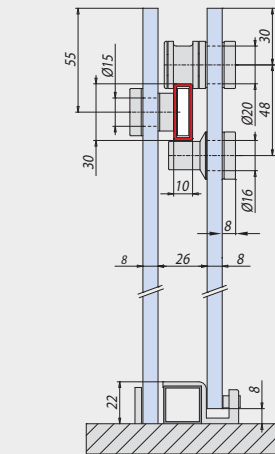

$HM = H - 8$
 $HF = H$

OPTIONAL

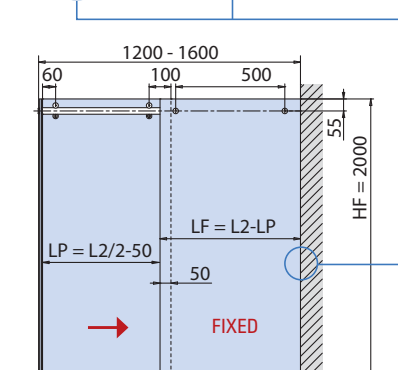
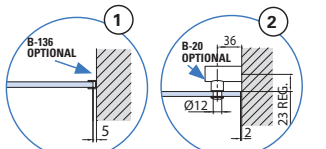
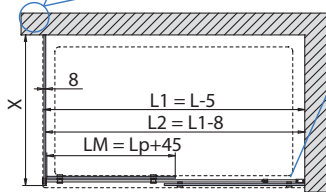
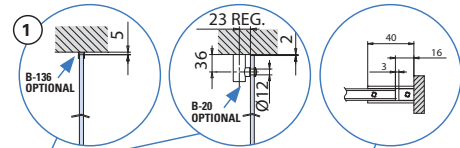

CALCOLO VETRO / CALCULATION GLASS /
GLASBERECHNUNG

$L = 1200 \text{ mm} \rightarrow 1800 \text{ mm}$
 $L1 = L - 5 \times 2$
 $L2 = L1 - 8$
 $LP = L2 / 2 - 50$
 $LM = LP + 45$
 $LF = (L2 - LP) - * \textcircled{1} / * \textcircled{2}$ (aria variabile /
clearance / Spaltmaß)
X = calcolare / calculate / berechnen
X = vedi $\textcircled{1} \textcircled{2}$ / see $\textcircled{1} \textcircled{2}$ / siehe $\textcircled{1} \textcircled{2}$
 $HM = H - 8 = 1992 \text{ mm}$
 $HFL = H - 2000 \text{ mm}$

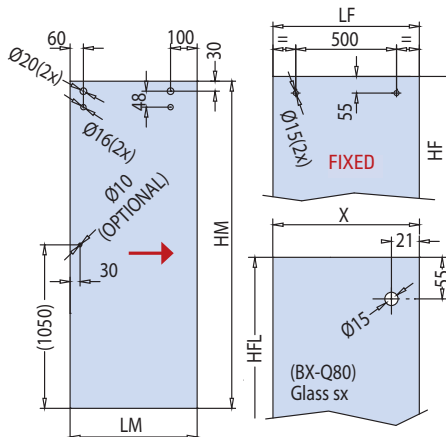

xme211a

L Piatto Shower tray Duschtaße	LP Passaggio luce Clear opening width Lichte Durchgangsbreite	LM Larghezza vetro mobile Sliding glass width Schiebeflügel Breite	LF Larghezza vetro fisso Side fixed glass width Seitenteil Breite	HM Altezza vetro mobile Sliding glass height Schiebeflügel Höhe	HF Altezza vetro fisso Side fixed glass height Seitenteil Höhe	H Altezza doccia Shower height Duschcabine Höhe	HFL Altezza vetro fisso laterale Side fixed glass height Seitenteil (seitlich) Höhe
--	---	--	---	---	--	---	---

BX-02

COMPONENTI / COMPONENTS / EINZELTEILE

SCORREVOLI



BX-Q43 / BX-Q40

- Binario
- Track profile
- Laufschiene

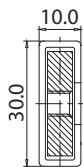

e▶ B.140

Cod.	Fin./Fin./Oberf.
BX-Q43-1800 mm	IL
BX-Q43-2800 mm*	IL
BX-Q40-830 x 830 mm (2 pcs)	IL

*Senza fori / Without holes / Ohne Bohrungen

xfb-044



BX-Q10

- Ruota con perno antiscoppio
- Roller with anti-jump pin
- Laufrolle und Ausbebeschutz

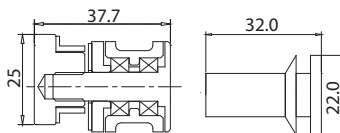

e▶ B.141

xfb-044



BX-Q70

- Punto di fissaggio vetro fisso al binario
- Fixing point for fixed glass and track profile
- Punkthalter für Fixierung des Festteils auf Laufschiene

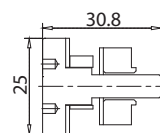

e▶ B.142

xfb-044



BX-Q90

- Attacco a parete per binario
- Wall connector for track profile
- Wandhalter für Laufschiene

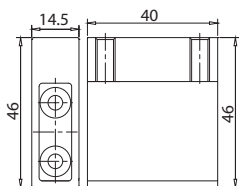

e▶ B.143

xfb-044



BX-Q30

- Stopper

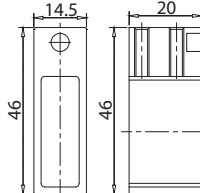

e▶ B.144

xfb-044



BX-Q20

- Connettore ad angolo per binario
- Corner connector for track profile
- Winkelverbinder Laufschiene

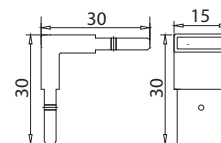

e▶ B.145

xfb-044



BX-Q80

- Attacco a vetro per binario
- Glass connector for track profile
- Glashalter für Laufschiene

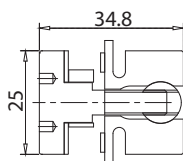

e▶ B.146

xfb-044



BX-C50

- Guida a pavimento
- Floor guide
- Bodenführung

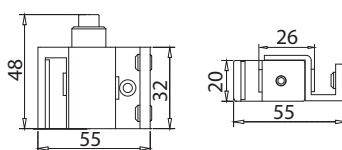

e▶ B.148

xfb-044



BX-C58 / BX-C55

- Profilo a terra
- Floor profile
- Bodenprofil

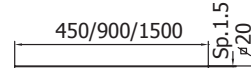

e▶ B.132

Cod.	Fin./Fin./Oberf.
BX-C58-1500 mm	IL
BX-C58-900 mm	IL
BX-C55-450 mm	IL

bx-c58-bx-c55



BX-C60

- Coperchietto finale per profilo a terra BX-C55 / BX-C58
- Endcap for floor profiles BX-C55 / BX-C58
- Endkappe für Bodenprofile BX-C55 / BX-C58.

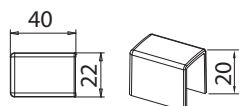

e▶ B.149

xla307



BX-C57

- Connettore ad angolo per profilo a terra
- Corner connector for floor profile
- Winkelverbinder für Bodenprofil

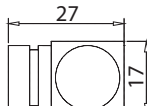

e▶ B.150

xfb-044



BX-Q45

- Tappo finale per binario
- Endcap for track profile
- Endkappe der Laufschiene

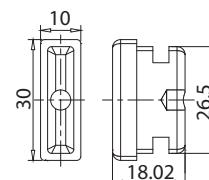

e▶ B.150.1

xfb-044



SCORREVOLI

A

BX-PT-01 STANDARD
COMPONENTI / COMPONENTS / EINZELTEILE

Per modelli: / For models: / Für Modelle:
BX-6000, BX-6020, BX-4000, BX-3100,
BX-1501, BX-2000,

- Vetro fisso nel profilo continuo H 16 mm.
- Fixed glass in shower entry floor profile H 16 mm.
- Festverglasung im Duscheinstieg Bodenprofil H 16 mm.

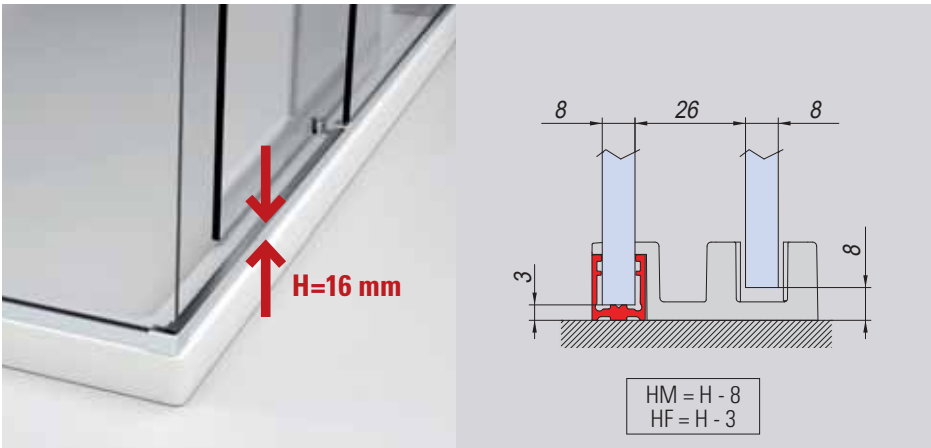

SCORREVOLI



BX-PT-C58

- Profilo a terra.
- Floor profile.
- Bodenprofil.

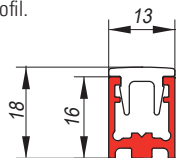

Cod.	Fin./Fin./Oberf.
BX-PT-C58-1500 mm	CR / NO
BX-PT-C58-3000 mm	CR / NO

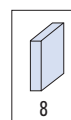

e► B.101



BX-PT-C56

- Coperchio per profilo a terra per tratto entrata doccia.
- Cover profile for floor profile, shower entry.
- Profilabdeckung Bodenprofil, Duscheinstieg.

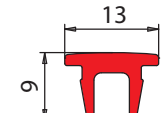

Cod.	Fin./Fin./Oberf.
BX-PT-C56-1500 mm	CR / NO
BX-PT-C56-3000 mm	CR / NO

e► B.102



BX-PT-C50

- Guida vetro scorrevole per applicazione con profilo a terra.
- Floor guide sliding panel for installation with floor profile.
- Schiebetür Bodenführung für Montage mit Bodenprofil.

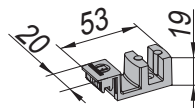

BX-PT-C51

- Angolo 90° vetro fisso/vetro fisso per profilo BX-PT-C58.
- Joint 90° fixed/fixed glass for profile BX-PT-C58.
- 90° Verbindung 2 Festverglasungen für Profil BX-PT-C58.

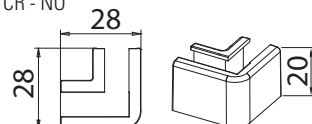

e► B.111



BX-PT-C57

- Angolo 90° lato entrata doccia ad angolo per profili BX-PT-C58 / BX-PT-C56.
- Joint 90° corner entry for profiles BX-PT-C58 / BX-PT-C56.
- 90° Verbindung Eckeinstieg für Profile BX-PT-C58 / BX-PT-C56.

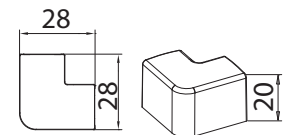

e► B.109



BX-PT-C52

- Angolo 90° per lato entrata doccia e lato vetro fisso dx e sx per profili BX-PT-C58 / BX-PT-C56.
- Joint 90° entry and fixed glass, left and right for profiles BX-PT-C58 / BX-PT-C56.
- 90° Verbindung Einstieg-Festverglasung, Links und Rechts für Profile BX-PT-C58 / BX-PT-C56.

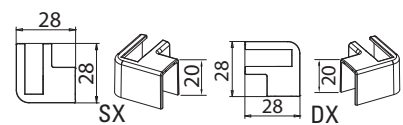

e► B.112



BX-PT-C60

- Coperchietto finale per profili BX-PT-C58 / BX-PT-C56.
- Endcap for profiles BX-PT-C58 / BX-PT-C56.
- Endkappe für Profile BX-PT-C58 / BX-PT-C56.

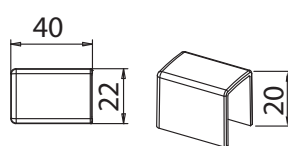

e► B.110

CR
Cromo lucido
Polished chrome
Chrom glänzend

NO
Nero opaco
Matt black
Matt schwarz

B BX-PT-02 SOLO PORTA OPTIONAL

COMPONENTI / COMPONENTS / EINZELTEILE

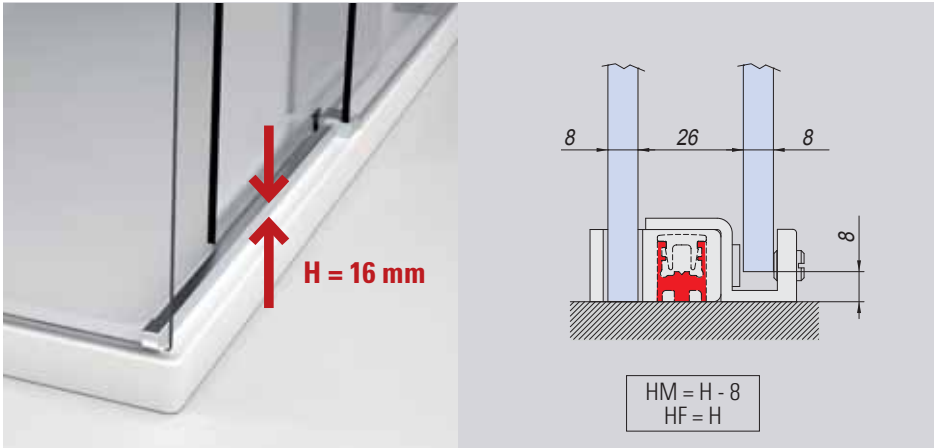

Per modelli: / For models: / Für Modelle:
BX-6000, BX-6020, BX-4000, BX-3100, BX-1501, BX-2000,

- Vetro fisso su piatto doccia, solo profilo entrata H 16 mm.
- Fixed glass on shower tray, only shower entry floor profile H 16 mm.
- Festverglasung auf Duschtasse, Duscheinstieg Bodenprofil H 16 mm.

SCORREVOLI



BX-PT-C58

- Profilo a terra.
- Floor profile.
- Bodenprofil.

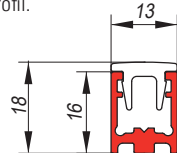

Cod.	Fin./Fin./Oberf.
BX-PT-C58-1500 mm	CR / NO
BX-PT-C58-3000 mm	CR / NO

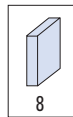
[e▶ B.101](#)

BX-PT-C56

- Coperchio per profilo a terra per tratto entrata doccia.
- Cover profile for floor profile, shower entry.
- Profilabdeckung Bodenprofil, Duscheinstieg.

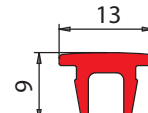

Cod.	Fin./Fin./Oberf.
BX-PT-C56-1500 mm	CR / NO
BX-PT-C56-3000 mm	CR / NO

[e▶ B.102](#)

BX-PT2-C50

- Guida vetro scorrevole per applicazione con profilo a terra.
- Floor guide sliding panel for installation with floor profile.
- Schiebetrür Bodenführung für Montage mit Bodenprofile.

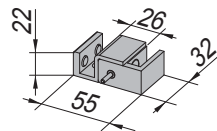

CR

[e▶ B.113](#)

BX-PT-C57

- Angolo 90° lato entrata doccia ad angolo per profili BX-PT-C58 / BX-PT-C56.
- Joint 90° corner entry for profiles BX-PT-C58 / BX-PT-C56.
- 90° Verbindung Eckeinstieg für Profile BX-PT-C58 / BX-PT-C56.

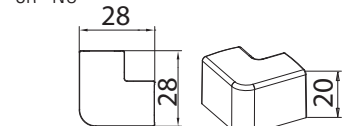

CR - NO

[e▶ B.109](#)

BX-PT-C51

- Angolo 90° vetro fisso/vetro fisso per profilo BX-PT-C58.
- Joint 90° fixed/fixed glass for profile BX-PT-C58.
- 90° Verbindung 2 Festverglasungen für Profil BX-PT-C58.

CR - NO

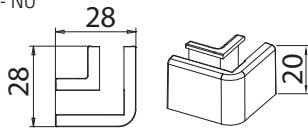
[e▶ B.111](#)

BX-PT-C52

- Angolo 90° per lato entrata doccia e lato vetro fisso dx e sx per profili BX-PT-C58 / BX-PT-C56.
- Joint 90° entry and fixed glass, left and right for profiles BX-PT-C58 / BX-PT-C56.
- 90° Verbindung Einstieg-Festverglasung, Links und Rechts für Profile BX-PT-C58 / BX-PT-C56.

CR - NO

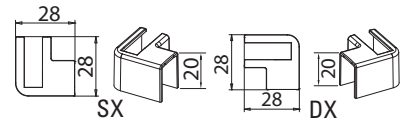
[e▶ B.112](#)

BX-PT-C60

- Coperchietto finale per profili BX-PT-C58 / BX-PT-C56.
- Endcap for profiles BX-PT-C58 / BX-PT-C56.
- Endkappe für Profile BX-PT-C58 / BX-PT-C56.

CR - NO

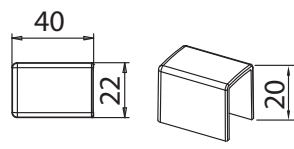
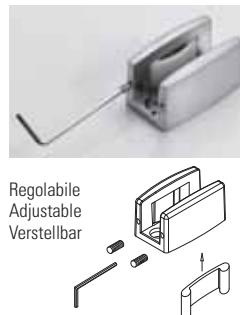
[e▶ B.110](#)

V-012-REG

- Guida a pavimento regolabile per vetro da 8 a 13,5 mm.
- Floor guide adjustable for glass from 8 to 13,5 mm.
- Bodenführung verstellbar für Glas von 8 bis 13,5 mm.

AN - NS - CR

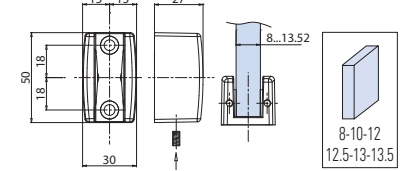
[e▶ B.117.1](#)

CR
 Cromo lucido
 Polished chrome
 Chrom glänzend

NO
 Nero opaco
 Matt black
 Matt schwarz

AN
 Alluminio anodizzato
 Aluminium anodized
 Aluminium Silberfarbig

NS
 Nickel satinato
 Satin nickel
 Ähnlich Edelstahl matt

C

BX-PT-03 RASO DOCCIA OPTIONAL
COMPONENTI / COMPONENTS / EINZELTEILE

Per modelli: / For models: / Für Modelle:
BX-6000, BX-6020, BX-4000, BX-3100,
BX-1501, BX-2000,

- Vetro fisso su piatto doccia, profilo entrata H 8 mm.
- Fixed glass on shower tray, shower entry floor profile H 8 mm.
- Festverglasung auf Duschtasse, Duscheinstieg Bodenprofil H 8 mm.

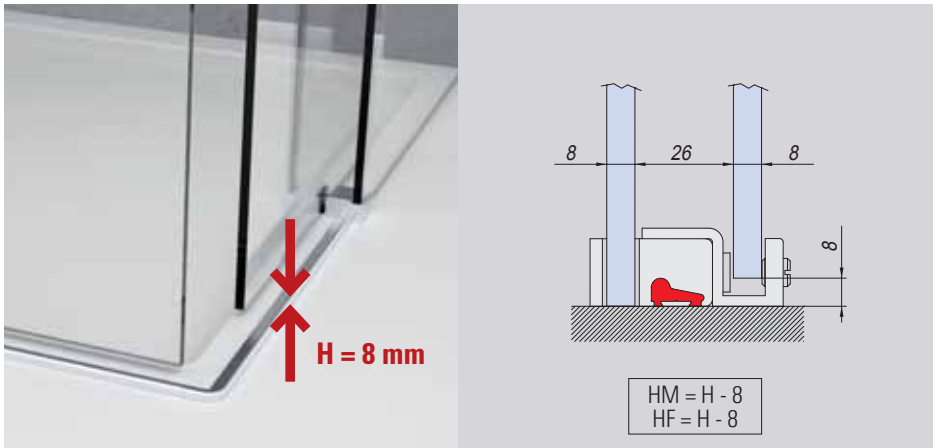

SCORREVOLI



P-017

- Profilo gocciolatoio
- Splash guard profile
- Schwallenschutz Profil CR

e► **B.238**

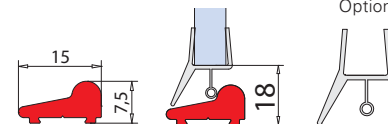

B-147
Option

Cod.	Fin./Fin./Oberf.
P-017-2100 mm	CR



BX-PT3-C50

- Guida vetro scorrevole per applicazione con profilo a terra P-017.
- Floor guide sliding panel for installation with floor profile P-017.
- Schiebetür Bodenführung für Montage mit Bodenprofil P-017. CR

e► **B.114**

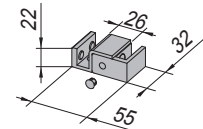

BX-PT3-C57

- Angolo 90° lato entrata doccia per profili P-017.
- Joint 90° corner entry for profiles P-017.
- 90° Verbindung Eckeinstieg für Profile P-017. CR

e► **B.116**

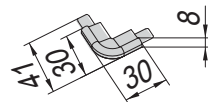

BX-PT3-C60

- Coperchietto finale per profili P-017, destro e sinistro.
- Endcap for profiles P-017, left and right.
- Endkappe für Profile P-017 Links und Rechts. CR

e► **B.117**

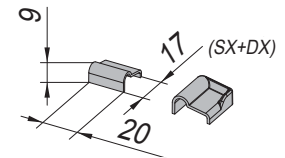

V-012-REG

- Guida a pavimento regolabile per vetro da 8 a 13,5 mm.
- Floor guide adjustable for glass from 8 to 13,5 mm.
- Bodenführung verstellbar für Glas von 8 bis 13,5 mm. AN - NS - CR

e► **B.117.1**

Regolabile
Adjustable
Verstellbar

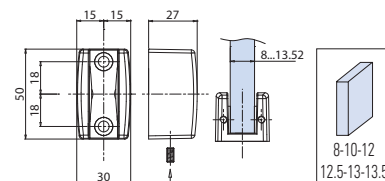
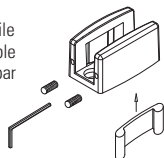

CR
Cromo lucido
Polished chrome
Chrom glänzend

AN
Alluminio anodizzato
Aluminium anodized
Aluminium Silberfarbig

NS
Nickel satinato
Satin nickel
Ähnlich Edelstahl matt



SCORREVOLI



BOX DOCCIA CON SISTEMA SCORREVOLE A SOFFIETTO

SHOWER BOX WITH SYSTEM FOR CABIN WITH FOLDING DOOR

DUSCHKABIN MIT SYSTEM FÜR FALTÜREN



SOFFIETTI

BX-2700

- Sistema scorrevole per box doccia pieghevole a soffietto. Materiale: alluminio finitura cromo lucido.
- System for showers cabin with folding doors for niche. Material: aluminium Polished Chrome.
- System für Duschkabinen mit Faltüren. Material: Aluminium chrom poliert.

► 94

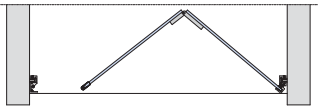

BX-2600

- Sistema scorrevole per box doccia pieghevole a soffietto disponibile nella versione in nicchia. Materiale: alluminio finitura cromo lucido.
- System for shower cabin with folding doors for niche. Material: aluminium Polished Chrome.
- System für Duschkabin mit Faltüren für Nische. Material: Aluminium Chrom poliert.

► 100

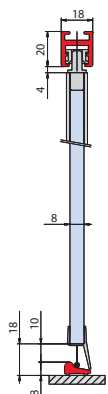
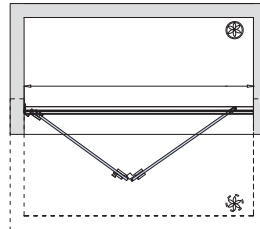

SET 2 (e► B.151)

SET 4 (e► B.152)

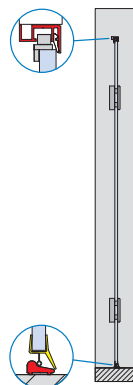
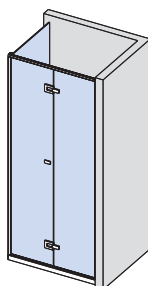
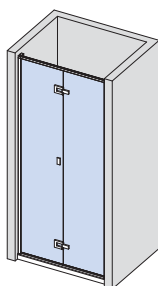

SET 2 (e► B.172)

SET 4 (e► B.173)

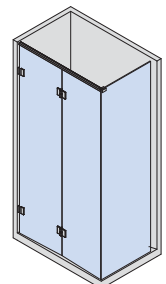
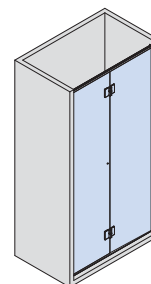

BX-2700



SOFFIETTI

Profili vetro fisso
Profiles for fixed panels
Profil für Festverglasung... ▶ 140

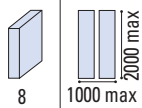
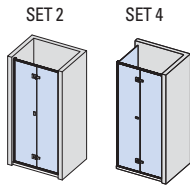
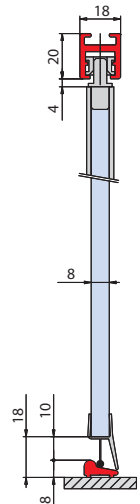

Fin. / Fin. / Oberf.
CR
Cromo lucido
Polished chrome
Chrom glänzend

COMPONENTI / COMPONENTS / EINZELTEILE

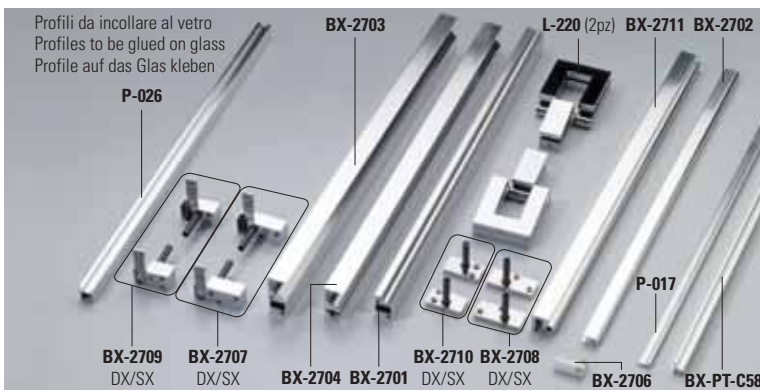

BX-2700 SET 2

▶ B.151

DOCCIA IN NICCHIA / NICHE SHOWER / NISCHENDUSCHE

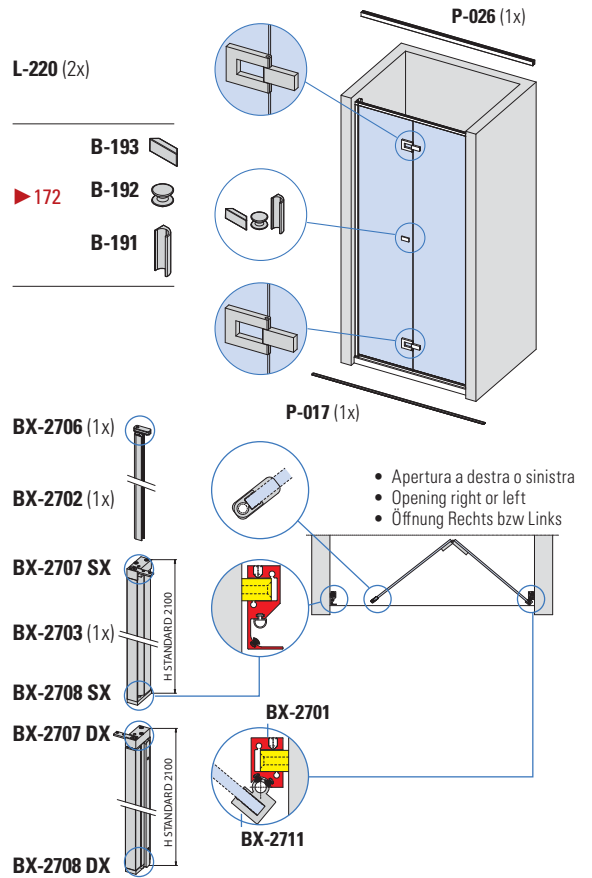

BX-2700 SET 4

▶ B.152

DOCCIA CON SPALLA IN VETRO / CORNER SHOWER WITH 2 FIXED PANEL / ECKDUSCHE MIT 2 FESTSTEHENDEN GLASTAFELN

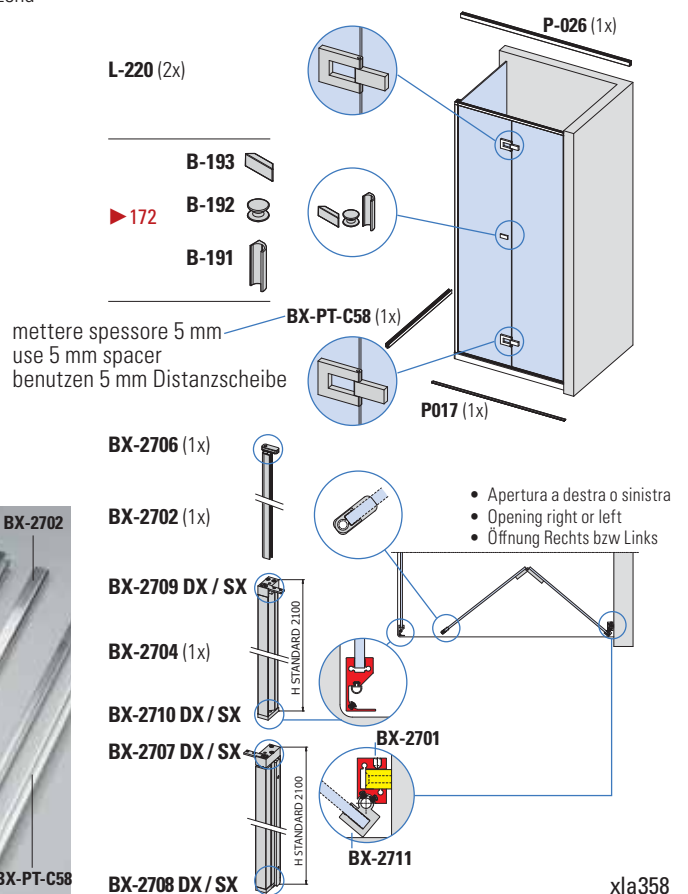

L = P1 (1000) mm MAX
 LM1 = LM2 = L1 - 36 / 2
 LA1 = LM + 10
 LA2 = LM2 + 4
 HM1 = HM2 = 2058

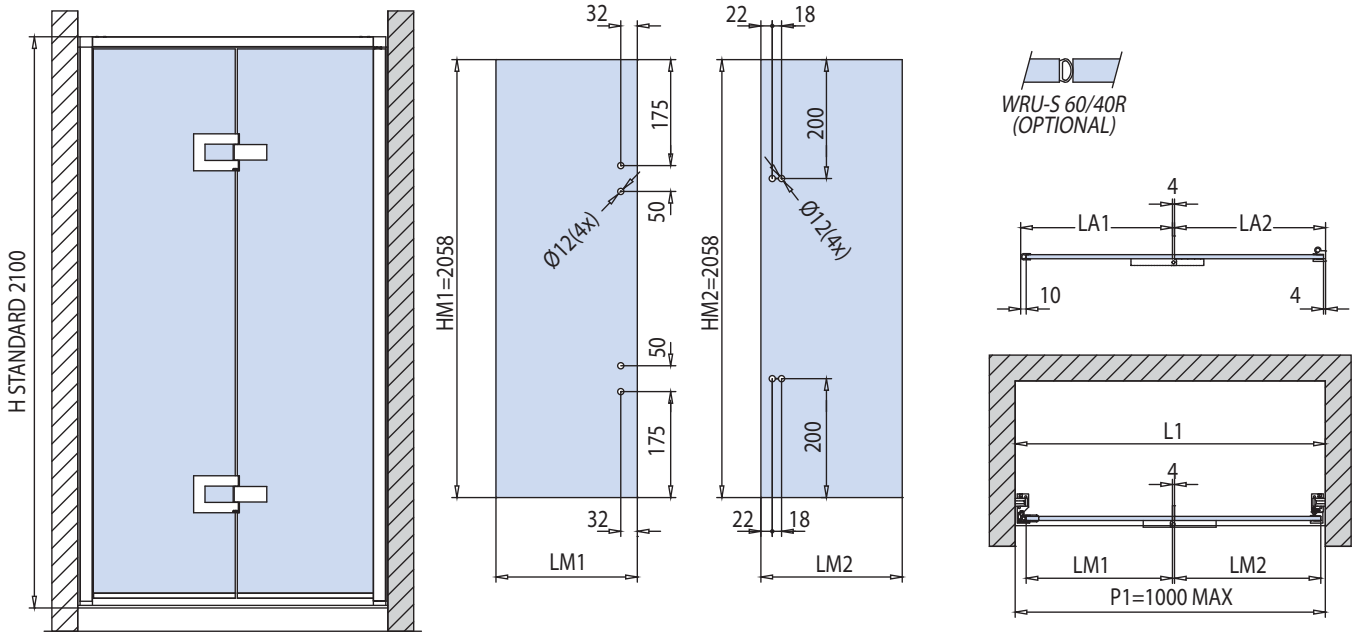

SOFFIETTI

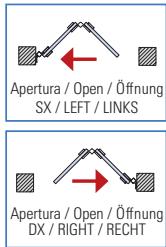

- Indicare sempre il senso di apertura.
- Please specify always opening direction.
- Bitte immer Öffnungsrichtung angeben.

P1 = P2 (1000) mm MAX
 L = P1 - 12
 LM1 = LM2 = L1 - 24 / 2
 L3 = P2 - 5
 LF = (L3 - 35) - **A** aria variabile / clearance / Spaltmaß ▶ 138
 LA1 = LM1 + 10
 LA2 = LM2 + 4
 HM1 = HM2 = 2058
 HF = 2070

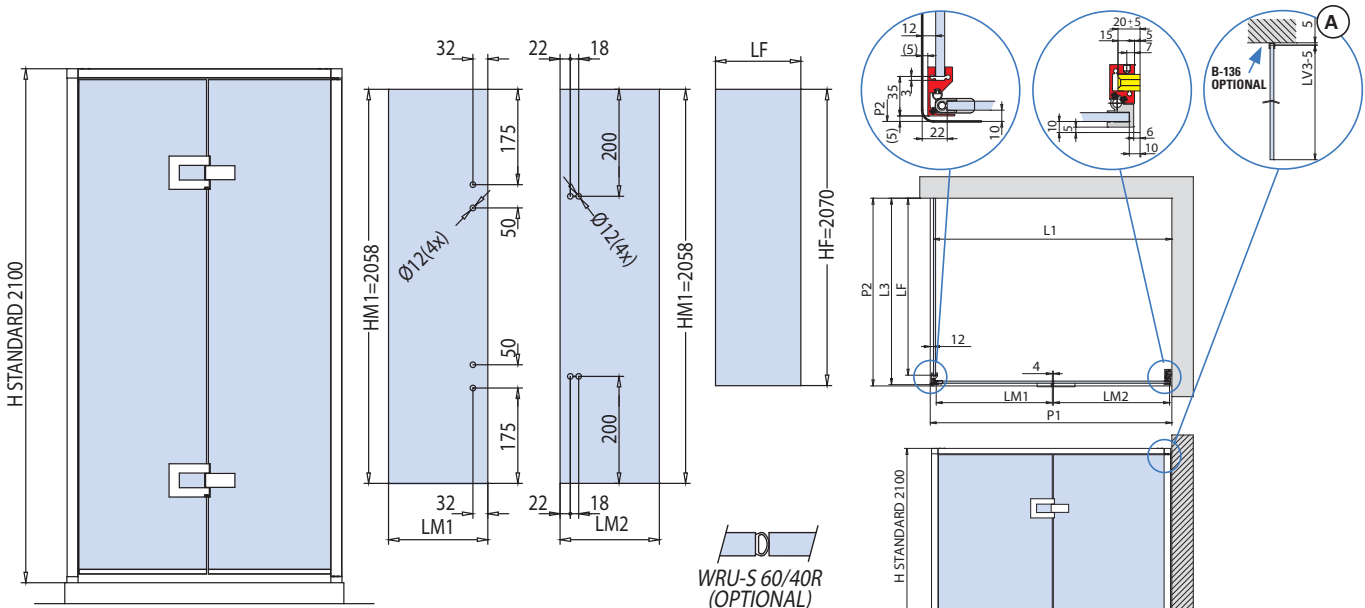

xla358F

L	LA	LM	HM	HF	LF	H
Piatto Shower tray Duschtaße	Larghezza anta Door width Tür-Breite	Larghezza vetro mobile Sliding glass width Glasbreite	Altezza vetro mobile Glass height Glashöhe	Altezza vetro fisso Side fixed glass height Seitenteil Höhe	Larghezza vetro fisso Side fixed glass width Seitenteil Breite	Altezza doccia Shower height Duschkabine Höhe

BX-2700

COMPONENTI / COMPONENTS / EINZELTEILE



- P-026**
- Binario
 - Track profile
 - Laufschiene

► B.153

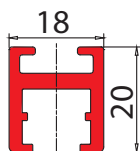

Cod.	Fin./Fin./Oberf.
P-026-1000 mm	CR

xfb-062



- BX-2703**
- Profilo battuta a muro compreso di guarnizione
 - Door stop profile with gasket
 - Türanschlagsprofil mit Dichtung

► B.156

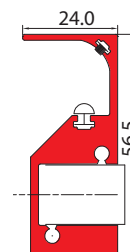

Cod.	Fin./Fin./Oberf.
BX-2703-2200 mm	CR

xfb-062



- BX-2701**
- Profilo a muro per fissaggio profilo cerniera BX-2711
 - Wall profile for installation hinge profile BX-2711
 - Wandprofil für Befestigung des Bandprofil BX-2711

► B.154

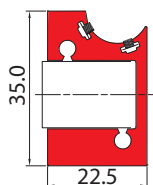

Cod.	Fin./Fin./Oberf.
BX-2701-2200 mm	CR

xfb-062



- BX-2704**
- Profilo battuta a vetro compreso di guarnizione
 - Door stop profile glass installation with gasket
 - Türanschlagsprofil Glasmontage mit Dichtung

► B.157



Cod.	Fin./Fin./Oberf.
BX-2704-2200 mm	CR

xfb-062



- BX-2702**
- Profilo bordo vetro
 - Border profile
 - Rahmenprofil

► B.155

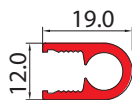

Cod.	Fin./Fin./Oberf.
BX-2702-2200 mm	CR

xfb-062

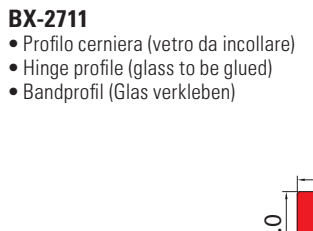

- BX-2711**
- Profilo cerniera (vetro da incollare)
 - Hinge profile (glass to be glued)
 - Bandprofil (Glas verkleben)

► B.158

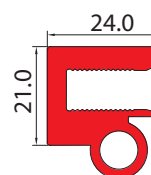

Cod.	Fin./Fin./Oberf.
BX-2711-2200 mm	CR

xfb-062

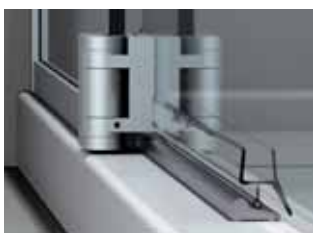

- P-017**
- Profilo gocciolatoio
 - Splash guard profile
 - Schwallenschutz Profil

► B.159

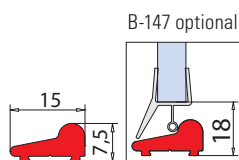

Cod.	Fin./Fin./Oberf.
P-017-2100 mm	CR

xme 203



- BX-PT-C58**
- Profilo a terra
 - Floor profile
 - Bodenprofil

► B.101

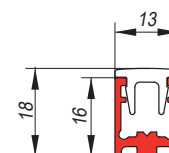

Cod.	Fin./Fin./Oberf.
BX-PT-C58-2200 mm	CR

xla367b

SOFFIETTI

BX-2706

- Perno guida superiore
- Top guiding pin
- Oberer Führungsstift

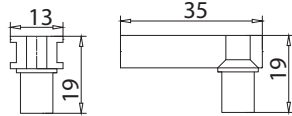
[e▶ B.161](#)

xfb-062

BX-2707-DX

- Attacco destro a parete per binario
- Right wall connector for track profile
- Wandhalter rechts für Laufschiene

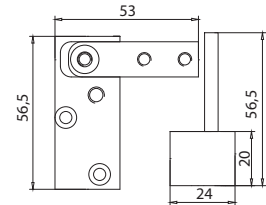
[e▶ B.164](#)

xfb-062

BX-2707-SX

- Attacco sinistro a parete per binario
- Left wall connector for track profile
- Wandhalter links für Laufschiene

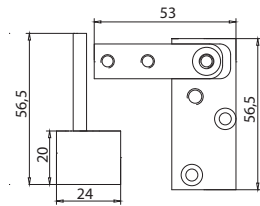
[e▶ B.165](#)

xfb-062

BX-2709-DX

- Attacco destro a vetro per binario
- Right glass connector for track profile
- Glashalter rechts für Laufschiene

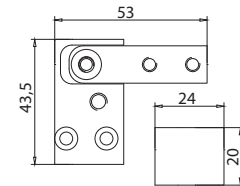
[e▶ B.168](#)

xfb-062

BX-2709-SX

- Attacco sinistro a vetro per binario
- Left glass connector for track profile
- Glashalter links für Laufschiene

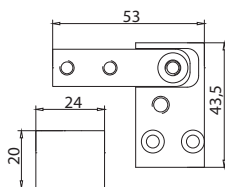
[e▶ B.169](#)

xfb-062

BX-2708-DX

- Piastra inferiore laterale destra
- Bottom right-side plate
- Unterer Platte rechts

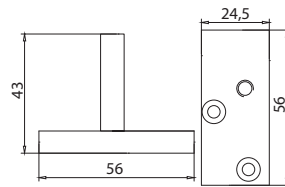
[e▶ B.167](#)

xfb-062

BX-2708-SX

- Piastra inferiore laterale sinistra
- Bottom left-side plate
- Unterer Platte links

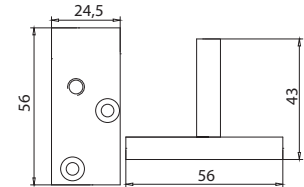
[e▶ B.167](#)

xfb-062

BX-2710-SX

- Piastra inferiore laterale sinistra per BX-2704
- Bottom left-side plate for BX-2704
- Unterer Platte links für BX-2704

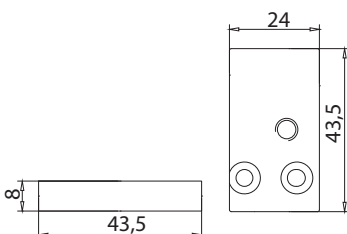
[e▶ B.170](#)

xfb-062

BX-2710-DX

- Piastra inferiore laterale destra per BX-2704
- Bottom right-side plate for BX-2704
- Unterer Platte rechts für BX-2704

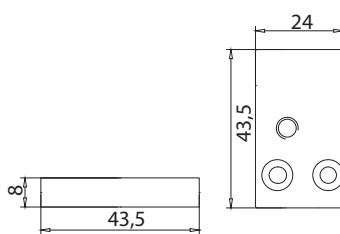
[e▶ B.171](#)

xfb-062

L-220

- Cerniera a scatto vetro/vetro, senza viti in vista. Materiale: Zamak.
- Glass to glass clicking hinge, with not visible screws. Material: Zamak.
- Duschtürband Glas-Glas ohne sichtbaren Schrauben. Material: Zamak. CR

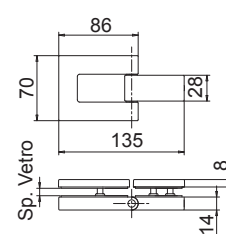
[e▶ B.163](#)

I-2600

BX-2700

► 94



SOFFIETTI

BX-2600

▶ 100



SOFFIOTTI

BX-2600



BX-2600 SET 2

e▶ B.172

DOCCIA IN NICCHIA / NICHE SHOWER / NISCHENDUSCHE

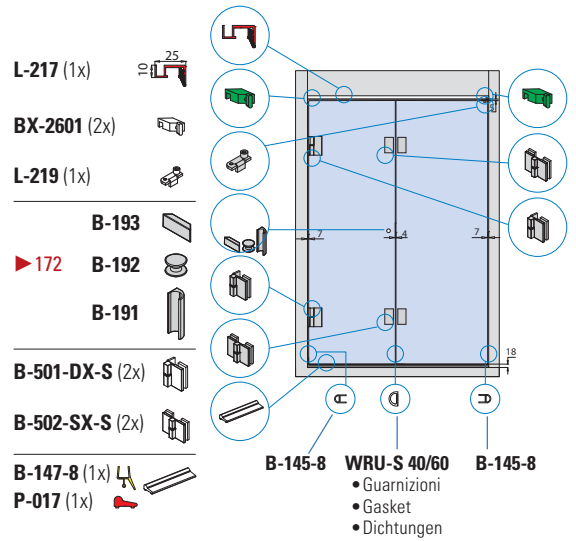

xme300

Profili vetro fisso
Profiles for fixed panels
Profil für Festverglasung...▶ 140

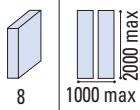

Fin. / Fin. / Oberf.
CR
Cromo lucido
Polished chrome
Chrom glänzend

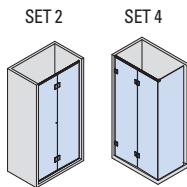
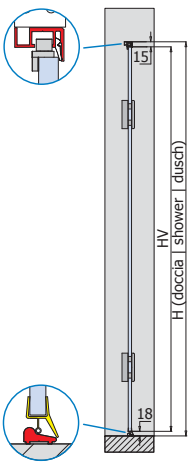

- Indicare sempre il senso di apertura.
- Please specify always opening direction.
- Bitte immer Öffnungsrichtung angeben.

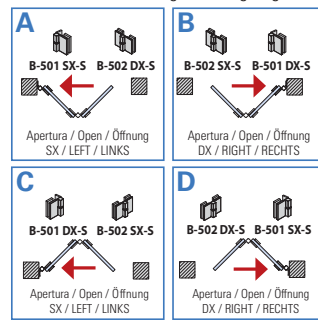

COMPONENTI / COMPONENTS / EINZELTEILE

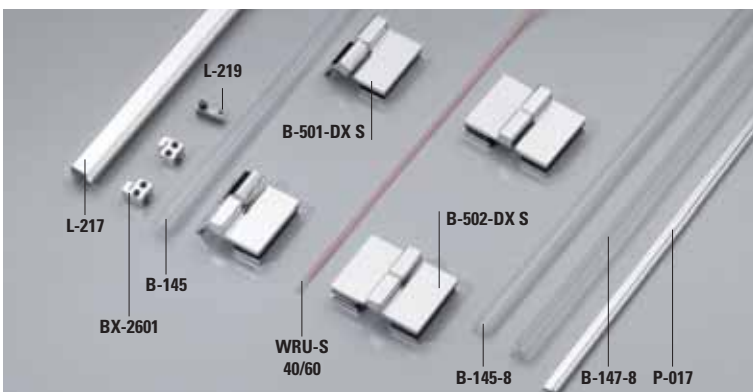

BX-2600 SET 4

e▶ B.173

DOCCIA CON SPALLA IN VETRO / CORNER SHOWER WITH 2
FIXED PANEL / ECKDUSCHE MIT 2 FESTSTEHENDEN GLASTAFELN

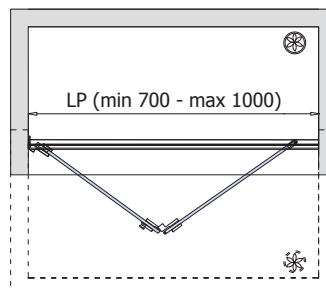
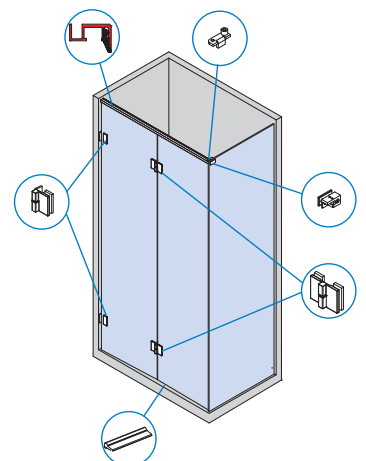
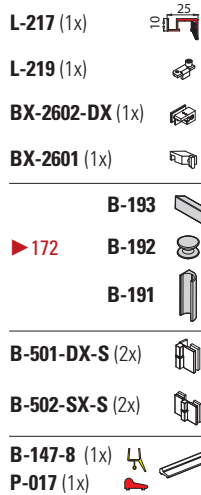

xme359

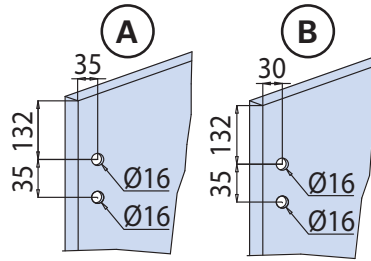
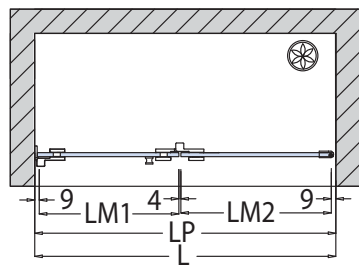
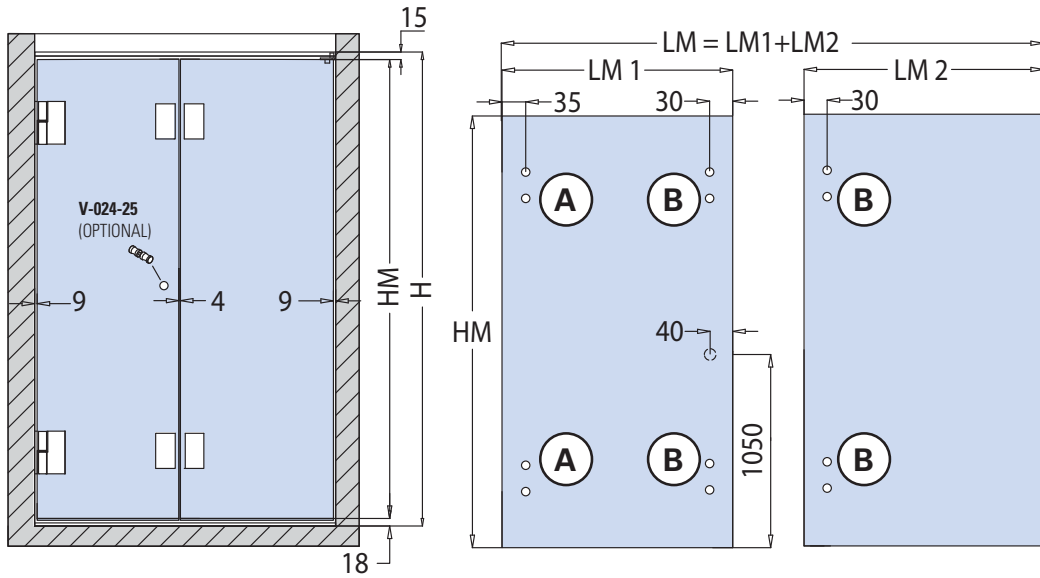

$$LM\ tot = LP - 22$$

$$LM1 = (LM\ tot / 2) - 9$$

$$LM2 = (LM\ tot / 2) + 9$$

$$HM = H - 33$$

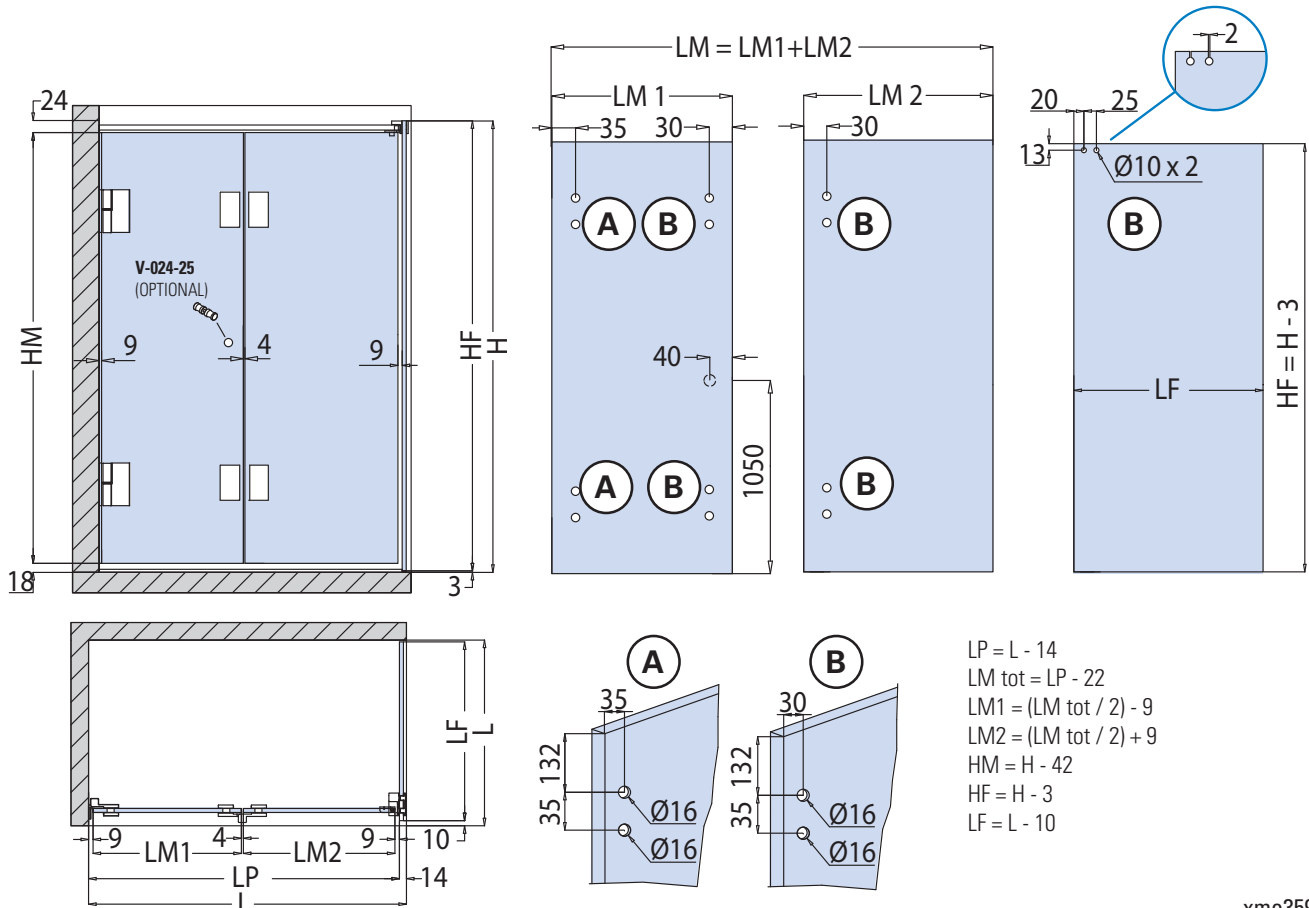

$$LP = L - 14$$

$$LM\ tot = LP - 22$$

$$LM1 = (LM\ tot / 2) - 9$$

$$LM2 = (LM\ tot / 2) + 9$$

$$HM = H - 42$$

$$HF = H - 3$$

$$LF = L - 10$$

xme359A

L
Piatto
Shower tray
Duschtaße

LF
Larghezza vetro fisso
Side fixed glass width
Seitenteil Breite

LM
Larghezza vetro mobile
Sliding glass width
Schiebefügel Breite

HM
Altezza vetro mobile
Sliding glass height
Schiebefügel Höhe

H
Altezza doccia
Shower height
Duschkabinen Höhe

HF
Altezza vetro fisso
Side fixed glass height
Seitenteil Höhe

BX-2600

COMPONENTI / COMPONENTS / EINZELTEILE

B-502 DX-S [e▶ B.175](#)

- Cerniera destra vetro/vetro
Materiale: Zamak.
- Right hinge glass to glass.
Material: Zamak.
- Band rechts Glas-Glas.
Material: Zamak.
CR

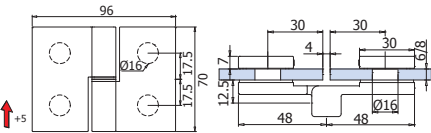

xmc016

B-502 SX-S [e▶ B.176](#)

- Cerniera sinistra vetro/vetro
Materiale: Zamak.
- Left glass to glass.
Material: Zamak.
- Band links Glas-Glas.
Material: Zamak.
CR

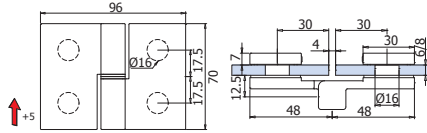

xmc016

B-501 DX-S [e▶ B.177](#)

- Cerniera destra vetro/muro
Materiale: Zamak.
- Right hinge wall to glass
Material: Zamak.
- Band rechts Wand-Glas
Material: Zamak.
CR

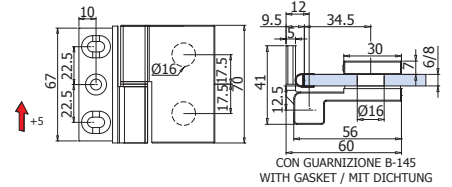

xmc016

B-501 SX-S [e▶ B.178](#)

- Cerniera sinistra vetro/
muro Materiale: Zamak.
- Left Hinge wall to glass
Material: Zamak.
- Band rechts Wand-Glas
Material: Zamak.
CR

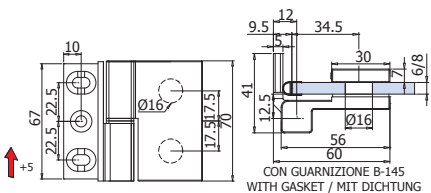

xmc016

L-217 [e▶ B.179](#)

- Binario
- Track profile
- Laufschiene

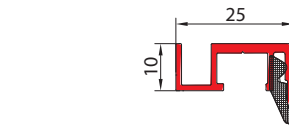

Cod.	Fin./Fin./Oberf.
L-217-1000 mm	CR

xfb-080

P-017 [e▶ B.180](#)

- Profilo gocciolatoio
- Splash guard profile
- Schwallenschutz Profil

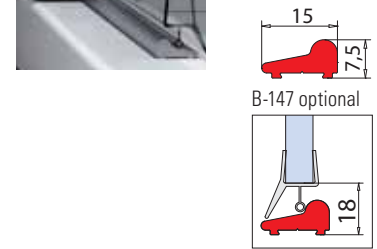

Cod.	Fin./Fin./Oberf.
P-017-2100 mm	CR

xme 203

L-219 [e▶ B.181](#)

- Perno guida superiore
(da incollare al vetro)
- Top guiding pin
(to be glued on glass)
- Führungsstift
(Auf das Glas Kleben)

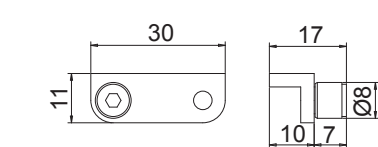

I-2600

BX-2601 [e▶ B.182](#)

- Attacco a parete
- Wall connector
- Wandhalter
CR

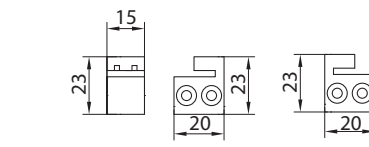

xfb-080

BX-2602 DX [e▶ B.183](#)

- Attacco destro a vetro
- Right glass connector
- Glashalter rechts
CR

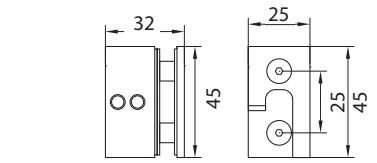

xfb-080

BX-2602 SX [e▶ B.184](#)

- Attacco sinistro a vetro
- Left glass connector
- Glashalter links
CR

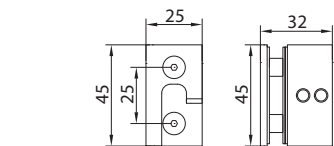

xfb-080

BX-2603 DX [e▶ B.185](#)

- Attacco destro a vetro
e attacco a parete
- Right glass connector
and wall connector
- Glashalter rechts
und Wandhalter
CR

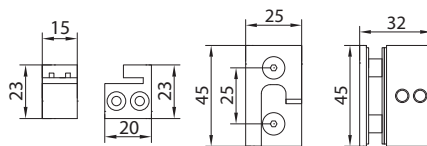

xfb-080

BX-2603 SX [e▶ B.186](#)

- Attacco sinistro a vetro
e attacco a parete
- Left glass connector
and wall connector
- Glashalter links
und Wandhalter
CR

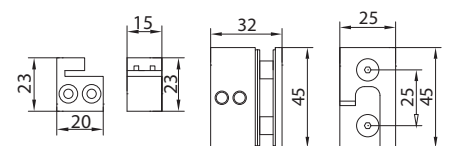

xfb-080

B-147-8 e▶ B.187

- Guarnizione gocciolatoio in PVC trasparente. Lunghezza barre 2200 mm. Per vetro da 8 mm
- Drip flap seal transparent PVC Bar length is 2200 mm. For 8 mm glass.
- Pvc Dichtprofil für den unteren Wannenanschluss für 8 mm oder Glas. Länge 2200 mm.

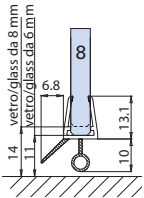

xme318

B-145-8 e▶ B.188

- Guarnizione a palloncino vetro/muro in PVC trasparente. L = 2200 mm
- Glass to wall ball seal transparent PVC. L = 2200 mm
- PVC Dichtprofil Glas-Wand. L = 2200 mm

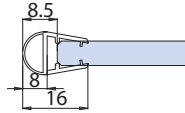

xme390

WRU-S 40/60

- Guarnizione neutra per vetro 8 mm. con fissaggio adesivo.
- Neutral gasket for glass 8 mm.self-adhesive
- Dichtungsprofil für 8 mm. selbstklebend

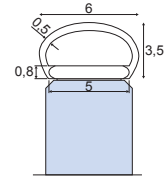
e▶ B.189

as2 sezione



BOX DOCCIA CON ANTA A BATTENTE

SHOWER BOX WITH SWING DOOR / DUSCHKABINEN MIT DREH-TÜR

- BOX DOCCIA CON ANTA A BATTENTE (CERNIERA A SCATTO)
- SHOWER BOX WITH SWING DOOR (DOUBLE ACTION CLICKING HINGES)
- DUSCHKABINEN MIT DREH-TÜR (SELBSTSCHLIESSENDE PENDEL TURBÄNDER)



B-701 ▶ 107

B-702 ▶ 107

B-301 ▶ 109



B-306 ▶ 109

L-220 ▶ 109

B-100 ▶ 110



B-101 ▶ 110

B-102 ▶ 110

B-103 ▶ 111



B-150 ▶ 111

B-400 ▶ 112

B-401 ▶ 112



B-402 ▶ 112

B-405 ▶ 113

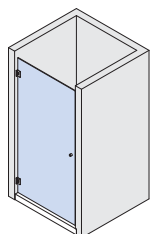

- CERNIERE A SCATTO IN BATTUTA (GUARNIZIONE CONTINUA)
- CLICKING HINGES FOR CONTINUOUS SEALS
- ANSCHLAGTÜRBÄNDER (DURCHGEHENDER DICHTUNG)



B-201 ▶ 115

B-202 ▶ 115

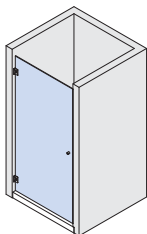

- CERNIERE CON ALZATA IN APERTURA
- HINGES WITH LIFT-LOWER FUNCTION
- BÄNDER MIT HEBE-SENK FUNKTION



BX-501 DX-SX ▶ 117

B-502 DX-SX ▶ 117

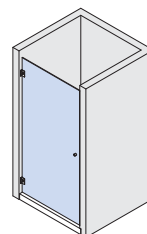

- CERNIERE IN BATTUTA (GUARNIZIONE CONTINUA)
- HINGES FOR CONTINUOUS SEALS
- ANSCHLAGTÜRBÄNDER (DURCHGEHENDER DICHTUNG)



B-711 ▶ 119 **B-712 ▶ 119** **B-104 ▶ 119**



B-105 ▶ 120 **B-601 DX-SX ▶ 120** **B-602 DX-SX ▶ 120**

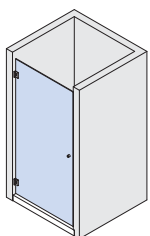

- PIVOT ALTO-BASSO (BILICO) - PORTA BATTENTE
- TOP/BOTTOM PIVOT HINGES
- OBERE/UNTERE PIVOT BÄNDER



BX-2100 BILICO ▶ 122



B-305 ▶ 128

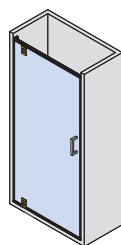

B-303 BILICA ▶ 130

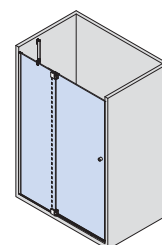

CERNIERE A SCATTO

CLICKING HINGES / SELBSTSCHLIESSENDE BÄNDER



- Sistemi per box doccia tutto vetro con cerniere a scatto, senza viti in vista.
- Frameless glass showers systems with double action clicking hinges, with not visible screws.
- Rahmenlosen Duschkabinensysteme aus Glas mit selbstschließende Pendeltürbänder, mit nicht sichtbaren Schrauben.



CERNIERE

B-701

 e▶ **B.204**

- Cerniera a scatto vetro muro regolabile posizione "0", senza viti a vista. Materiale: ottone.
- Glass to wall double action clicking hinge with not visible screws. "0" position adjustable. Material: Brass.
- Pendeltürband Glas-Wand ohne sichtbaren Schrauben, mit verstellbarer Nullagenstellung. Material: Messing. Nicht Verfügbar in Deutschland.

CR - NS - CP

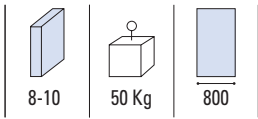
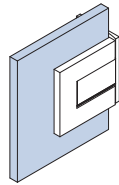
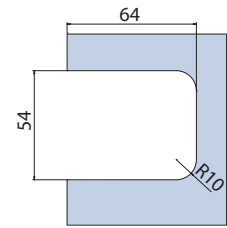
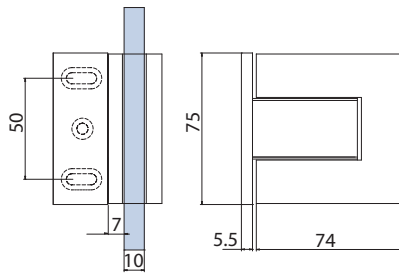
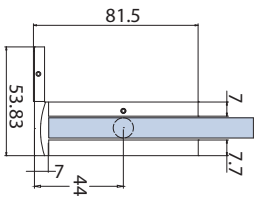
 LAVORAZIONE VETRO
 GLASS PREPARATION
 GLASBEARBEITUNG

xfb052

B-702

 e▶ **B.205**

- Cerniera a scatto regolabile vetro/vetro senza viti a vista. Materiale: ottone.
- Adjustable glass/glass clicking hinge with not visible screws. Material: Brass.
- Duschtürband Glas-Glas ohne sichtbare Schrauben, mit verstellbarer Nullagenstellung. Material: Messing. Nicht Verfügbar in Deutschland.

CR - NS - CP

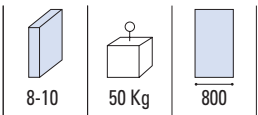
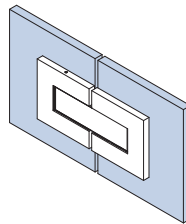
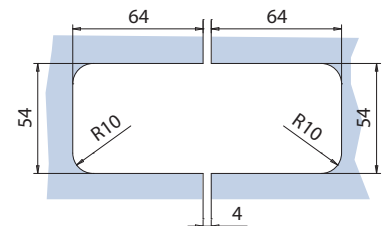
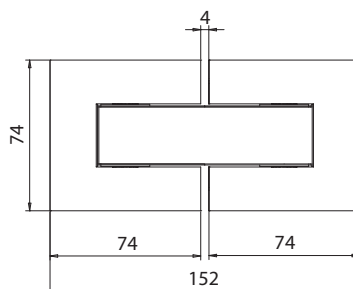
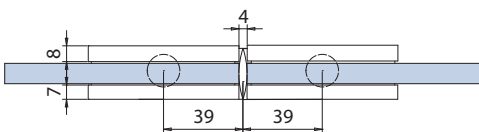
 LAVORAZIONE VETRO
 GLASS PREPARATION
 GLASBEARBEITUNG

xfb102

CR
 Cromo lucido
 Polished chrome
 Chrom glänzend

NS
 Nickel satinato
 Satin nickel
 Ähnlich Edelstahl matt

CP
 Cromo perla
 Chrome perla similar Alu
 Chrom perla ähnlich Alu

CERNIERE A SCATTO **CLICKING HINGES / SELBSTSCHLIESSENDE BÄNDER**



CERNIERE



 e▶ **B.212**
B-301

- Cerniera a scatto regolabile vetro/muro senza viti a vista. Materiale: Aletta fissaggio ottone. Cerniera Zamak.
- Adjustable glass to wall double action clicking hinge with not visible screws. Material: Fixing plate brass. Hinge Zamak.
- Pendeltürband Glas-Wand ohne sichtbaren Schrauben, mit verstellbarer Nulllagenstellung. Material: Anschraubplatte Messing. Band Zamak.

CR - NS

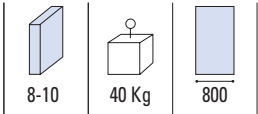
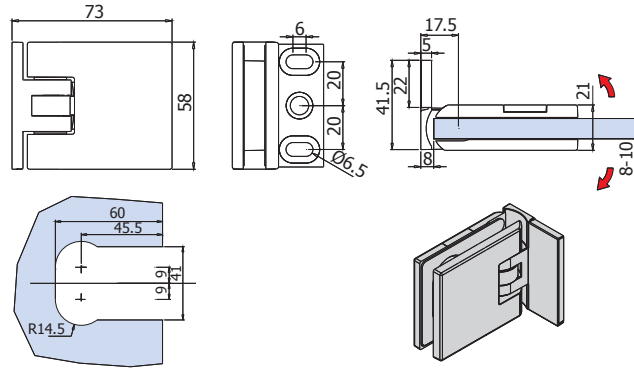

xme301

 e▶ **B.213**
B-306

- Cerniera a scatto regolabile vetro/vetro, senza viti a vista. Materiale: Zamak.
- Adjustable glass/glass double action clicking hinge, with not visible screws. Material: Zamak.
- Pendeltürband Glas-Glas ohne sichtbaren Schrauben, mit verstellbarer Nulllagenstellung. Material: Zamak.

CR - NS

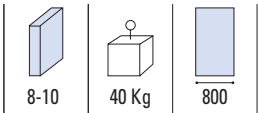
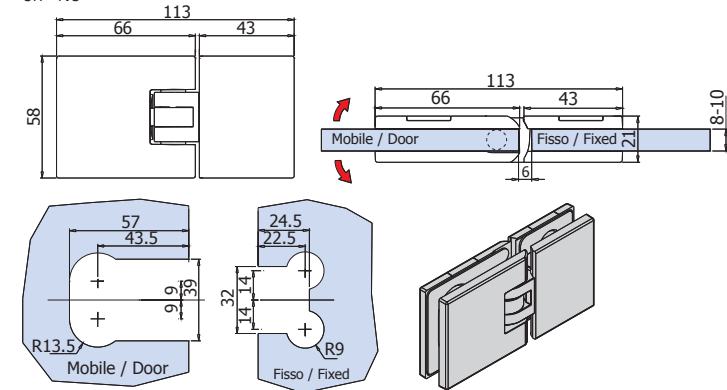

xme301

 e▶ **B.215**
L-220

- Cerniera a scatto vetro/vetro regolabile, senza viti in vista. Materiale: Zamak.
- Adjustable glass to glass clicking hinge, with not visible screws. Material: Zamak.
- Verstellbares duschtürband Glas-Glas ohne sichtbaren Schrauben. Material: Zamak.

CR - NS - CP

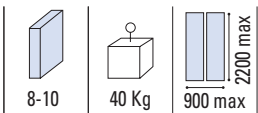
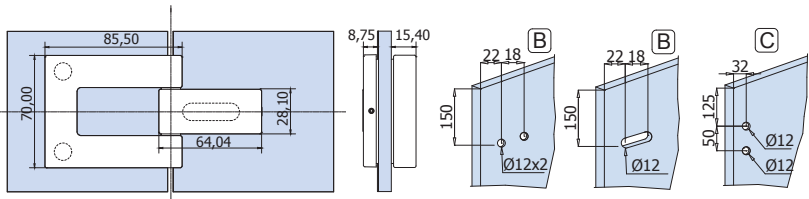

- B** = • Lavorazione vetro alternativa
 • Alternative glass preparation
 • Alternativ Glasbearbeitung

xme403

CR
 Cromo lucido
 Polished chrome
 Chrom glänzend

NS
 Nickel satinato
 Satin nickel
 Ähnlich Edelstahl matt

CP
 Cromo perla
 Chrome perla similar Alu
 Chrom perla ähnlich Alu

CERNIERE

CERNIERE A SCATTO

CLICKING HINGES / SELBSTSCHLIESSENDE BÄNDER



B-100

- Cerniera a scatto vetro/muro, regolabile. Materiale: Ottone.
 - Adjustable glass/wall double action clicking hinge. Material: Brass.
 - Pendeltürband Glas-Wand, mit verstellbarer Nulllagenstellung. Material: Messing.
- CR - NS - NO

► B.207

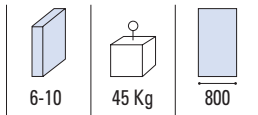
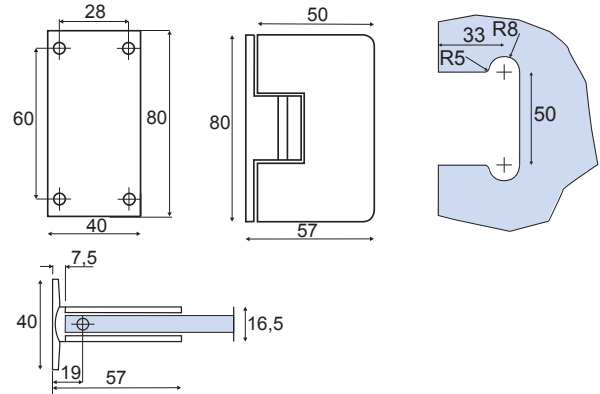

xme401



B-101

- Cerniera a scatto vetro/muro, aletta spostata. Materiale: Ottone.
 - Glass to wall double action clicking hinge with offset base. Material: Brass.
 - Pendeltürband mit einseitige Anschraubplatte Glas-Wand, mit verstellbarer Nulllagenstellung. Material: Messing.
- CR - NS - NO

► B.208

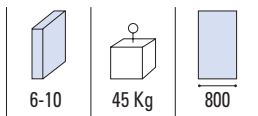
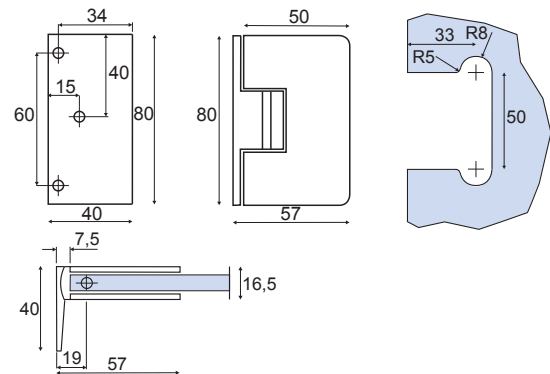

xme401



B-102

- Cerniera a scatto regolabile vetro/vetro, regolabile. Materiale: Ottone.
 - Adjustable glass to glass double action clicking hinge. Material: Brass.
 - Pendeltürband Glas-Glas 180°, mit verstellbarer Nulllagenstellung. Material: Messing.
- CR - NS - NO

► B.209

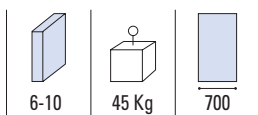
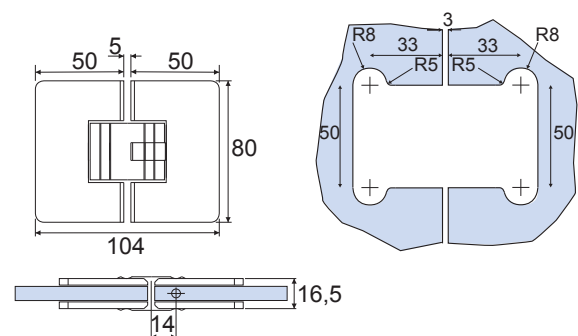

xme401



MORSETTI COORDINATI ▶ 160
COORDINATED CLAMPS
KOORDINIERTE KLEMMEN

B-103

 e▶ **B.210**

- Cerniera a scatto regolabile vetro/vetro 90°, regolabile. Materiale: Ottone.
- Adjustable 90° glass to glass double action clicking hinge. Material: Brass.
- Pendeltürband Glas-Glas 90°, mit verstellbarer Nulllagenstellung. Material: Messing.

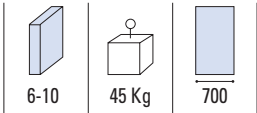
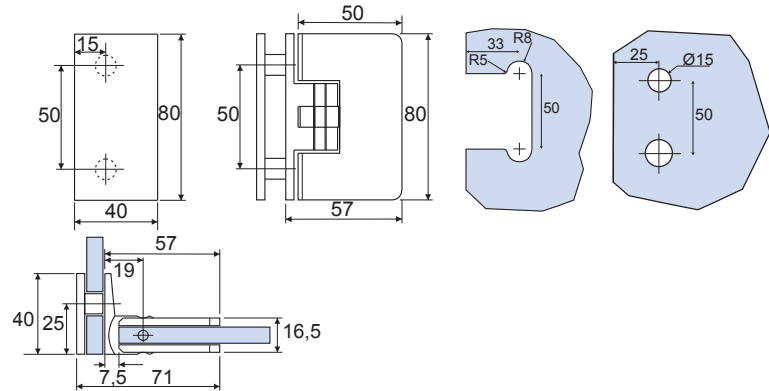
CR - NS



xme401

B-150

 e▶ **B.211**

- Cerniera a scatto regolabile vetro/muro, senza viti a vista.
- Adjustable glass/wall double action clicking hinge, without visible screws.
- Pendeltürband Glas-Wand mit verstellbaren Nulllagenstellung, ohne sichtbare Schrauben.

CR - NS

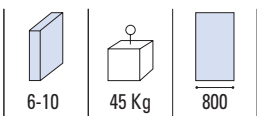
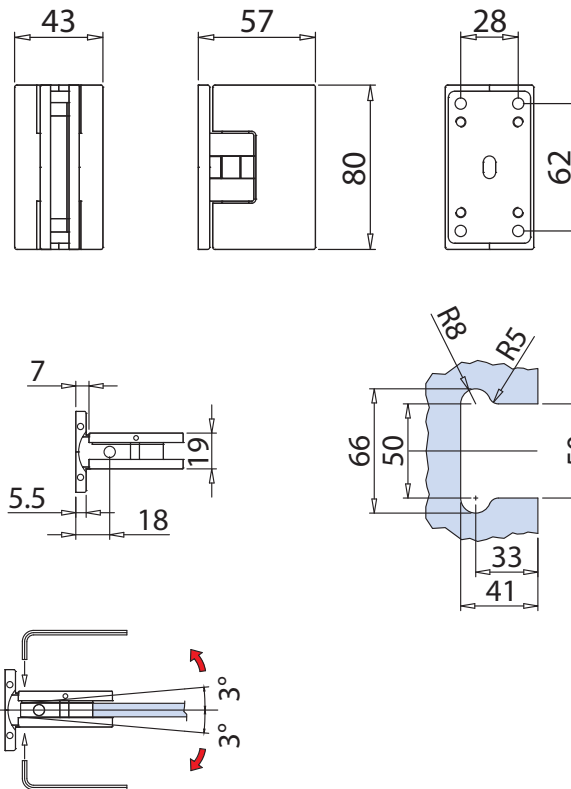
NEW
 WITH NOT VISIBLE
 SCREWS

CERNIERE

xfb084

CR
 Cromo lucido
 Polished chrome
 Chrom glänzend

NS
 Nickel satinato
 Satin nickel
 Ähnlich Edelstahl matt

NO
 Nero opaco
 Matt black
 Schwarz matt

CERNIERE A SCATTO

CLICKING HINGES / SELBSTSCHLIESSENDE BÄNDER



B-400

- Cerniera a scatto vetro/muro. Materiale: Zamak.
- Glass to wall double action clicking hinge. Material: Zamak.
- Pendeltürband Glas-Wand. Material: Zamak.

CR - NS

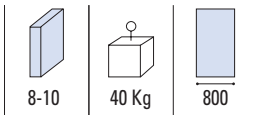
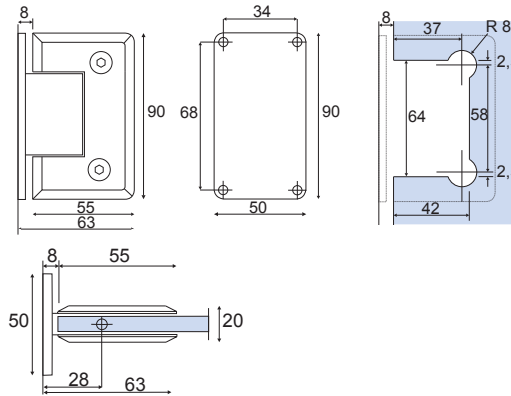

e▶ B.216

xme403



B-401

- Cerniera a scatto vetro/muro. Materiale: Zamak.
- Glass to wall double action clicking hinge with offset base. Material: Zamak.
- Pendeltürband Glas-Wand. Material: Zamak.

CR - NS

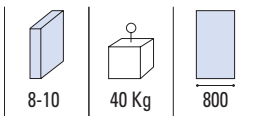
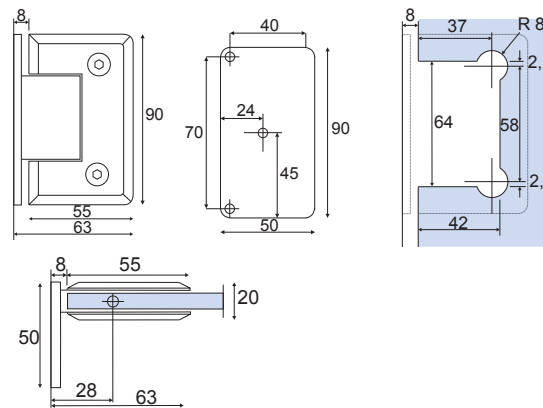

e▶ B.217

xme403



B-402

- Cerniera a scatto vetro/vetro. Materiale: Zamak.
- Glass to glass double action clicking hinge. Material: Zamak.
- Pendeltürband Glas-Glas. Material: Zamak.

CR - NS

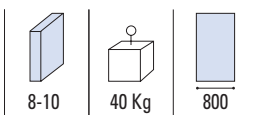
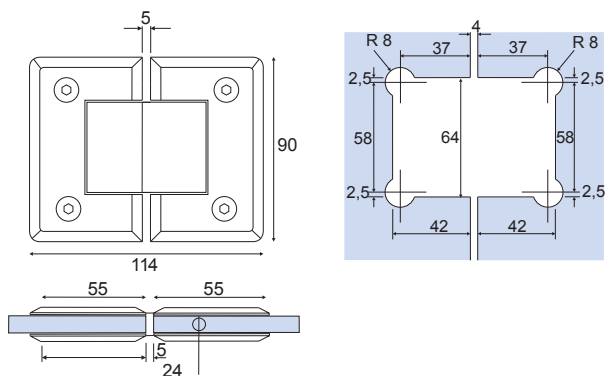

e▶ B.218

xme403

CERNIERE



MORSETTI COORDINATI ▶ 160
COORDINATED CLAMPS
KOORDINIERTE KLEMMEN



B-405

- Cerniera a scatto vetro/vetro 90°. Materiale: Zamak.
- Glass to glass double action clicking hinge 90°. Material: Zamak.
- Pendeltürband Glas-Glas 90°, beidseitig öffnend. Material: Zamak.

CR - NS

e▶ **B.219**

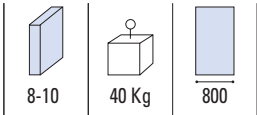
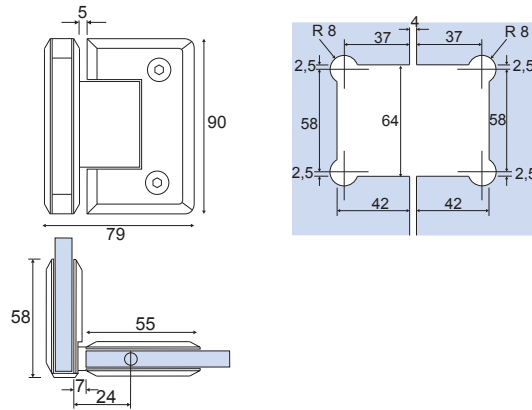

xme403



CR
 Cromo lucido
 Polished chrome
 Chrom glänzend

NS
 Nickel satinato
 Satin nickel
 Ähnlich Edelstahl matt

CERNIERE A SCATTO IN BATTUTA

CLICKING HINGES PULL TO OPEN FOR CONTINUOUS SEALS / ANSCHLAGTÜRBÄNDER FÜR DURCHGEHENDE DICHTUNG



- Sistemi per box doccia tutto vetro con cerniere a scatto, profili di battuta e a pavimento.
- Frameless glass showers systems with single action clicking hinges, door stop profiles and floor profiles.
- Rahmenlosen Duschkabinen-systeme aus Glas mit selbstschließenden Anschlagtürbänder, Türanschlagsprofile und Bodenprofile.



CERNIERE

MORSETTI COORDINATI ▶ 160
COORDINATED CLAMPS
KOORDINIERTE KLEMMEN

B-201

 e▶ **B.220**

- Cerniera a scatto vetro/muro apertura a tirare. Materiale: Ottone.
- Glass to wall single action clicking hinge, pull to open. Material: Brass.
- Anschlagtürband Glas-Wand nach außen öffnend. (Selbstschliessende Bänder) Material: Messing. CR - NS

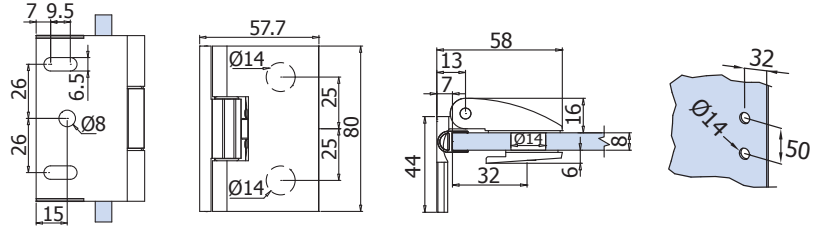

- Con guarnizione B-145
- With gasket B-145
- Mit Dichtung B-145

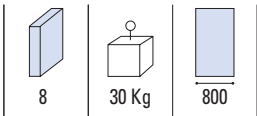

xmc015



B-202

 e▶ **B.221**

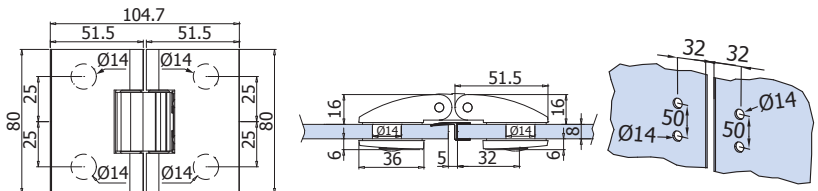
- Cerniera a scatto vetro/vetro apertura a tirare. Materiale: Ottone.
- Glass to glass single action clicking hinge pull to open. Material: Brass.
- Anschlagtürband Glas-Glas, nach außen hin öffnend. (Selbstschliessende Bänder) Material: Messing. CR - NS

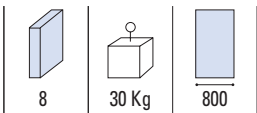

- Con guarnizione B-149
- With gasket B-149
- Mit Dichtung B-149



xmc015

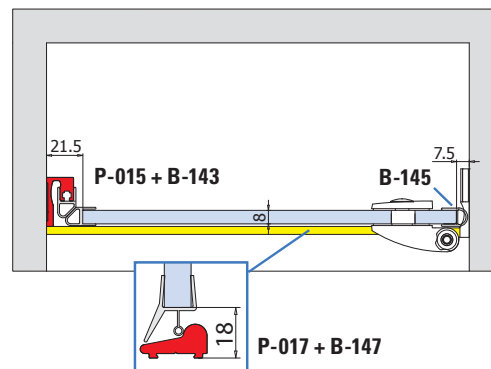
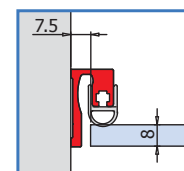
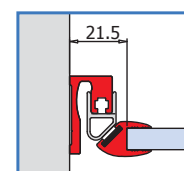

- Applicazione con profilo battuta P-015 (optional).
- Installation with door stop profile P-015 (optional).
- Verwendung mit Türanschlagsprofil P-015 (optional).

P-015 + B-146

P-015 + P-016 + B-148

CR
 Cromo lucido
 Polished chrome
 Chrom glänzend

NS
 Nickel satinato
 Satin nickel
 Ähnlich Edelstahl matt

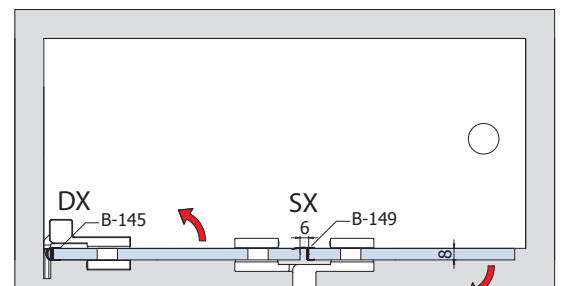
CERNIERE

CERNIERE CON ALZATA IN APERTURA HINGES WITH LIFT-LOWER FUNCTION / BÄNDER MIT HEBE-SENK FUNKTION



CERNIERE

B-501 DX-SX

e► B.222

- Cerniera vetro/muro con alzata in apertura. Materiale: Zamak.
- Hinge wall to glass with lift-lower function. Material: Zamak.
- Band Wand-Glas mit hebe-senk funktion. Material: Zamak.

CR - NS

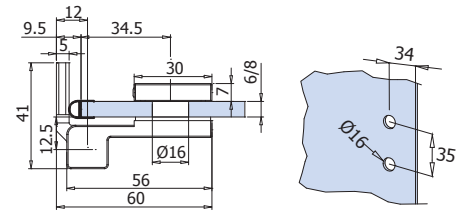
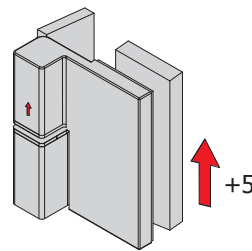
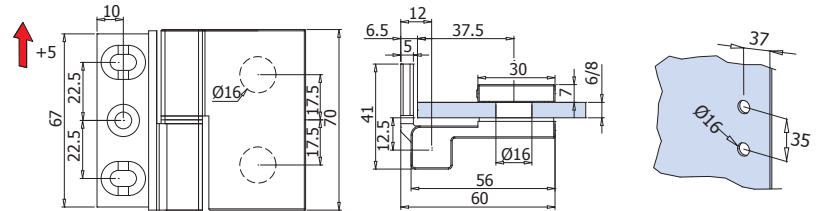

- Con guarnizione B-145
- With gasket B-145
- Mit Dichtung B-145

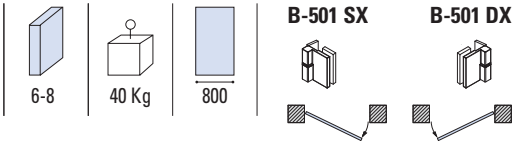

xmc016

CERNIERE

B-502 DX-SX

e► B.223

- Cerniera vetro/vetro con alzata in apertura. Materiale: Zamak.
- Hinge glass to glass with lift-lower function. Material: Zamak.
- Band Glas-Glas mit hebe-senk funktion. Material: Zamak.

CR - NS

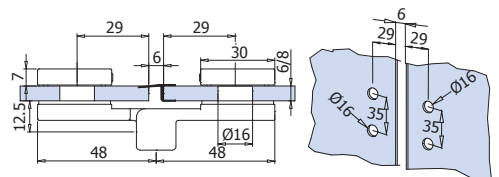
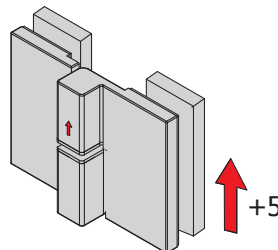
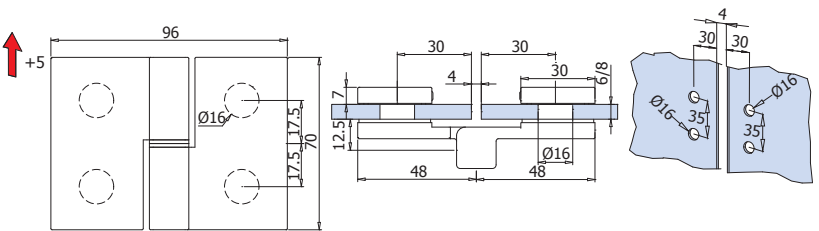

- Con guarnizione B-149
- With gasket B-149
- Mit Dichtung B-149

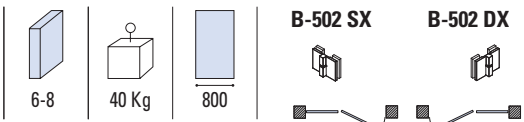

xmc016

CR
 Cromo lucido
 Polished chrome
 Chrom glänzend

NS
 Nickel satinato
 Satin nickel
 Ähnlich Edelstahl matt

CERNIERE LIBERE IN BATTUTA

HINGES FOR CONTINUOUS SEALS / ANSCHLAGTÜRBÄNDER FÜR DURCHGEHENDER DICHTUNG



- Sistemi per box doccia tutto vetro con cerniere libere, profili di battuta e a pavimento.
- Frameless glass showers systems with free hinges, door stop profiles and floor profiles.
- Rahmenlosen Duschkabinen-systeme aus Glas mit freie Anschlagtürbänder, Türanschlagsprofile und Bodenprofile.



CERNIERE



NEW
B-711

- Cerniera vetro muro. Materiale: zama.
- Glass to wall single action hinge. Material: zamak.
- Anschlagtürband Glas-Wand. Material: Zamak.

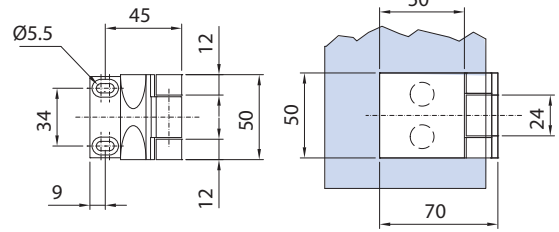
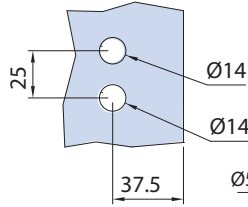
CR

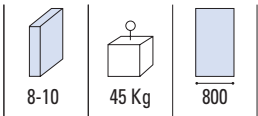

e► B.224

 OPTIONAL
B-145

xfb110



NEW
B-712

- Cerniera vetro/vetro. Materiale: zama.
- Glass to glass hinge. Material: zamak.
- Duschtürband Glas-Glas. Material: Zamak.

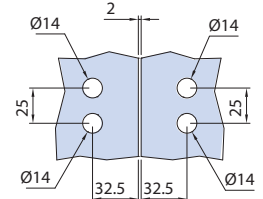
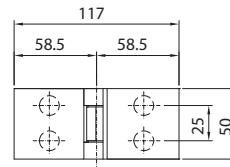
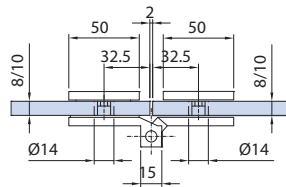
CR

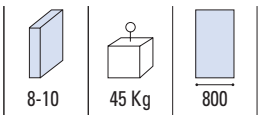
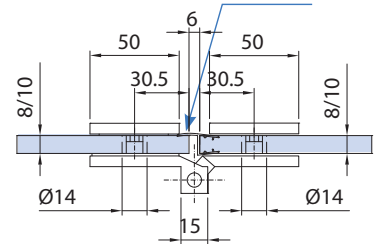

e► B.225

 OPTIONAL
B-149

xfb111



B-104

- Cerniera vetro/vetro. Materiale: ottone.
- Glass to glass hing. Material: brass.
- Duschtürband Glas-Glas. Material: Messing.

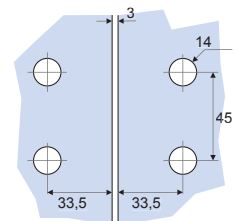
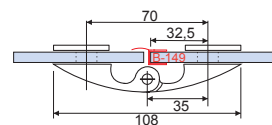
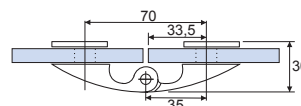
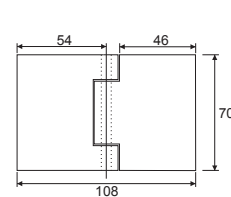
CR - NS

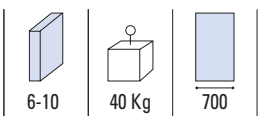

e► B.227



xme336

CR
 Cromo lucido
 Polished chrome
 Chrom glänzend

NS
 Nickel satinato
 Satin nickel
 Ähnlich Edelstahl matt

CERNIERE

MORSETTI COORDINATI ▶ 160
COORDINATED CLAMPS
KOORDINIERTE KLEMMEN



B-105

- Cerniera vetro/muro apertura a tirare. Materiale: ottone.
 - Glass to wall hinge, pull to open. Material: brass.
 - Duschtürband Glas-Wand nach außen öffnend. Material: Messing.
- CR - NS

e▶ **B.226**

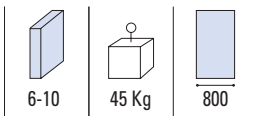
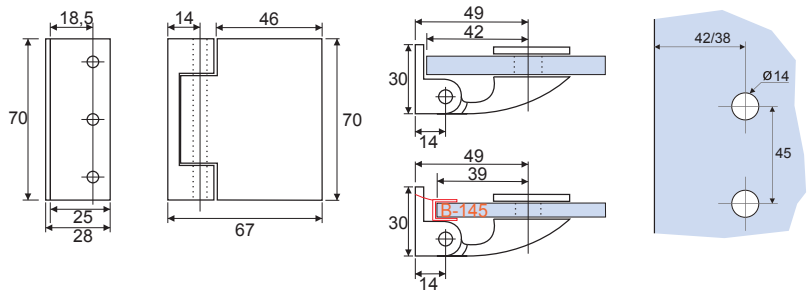

xme336



B-601 DX - SX

- Cerniera vetro/muro apertura a tirare. Materiale: ottone.
 - Glass to wall hinge, pull to open. Material: brass.
 - Duschtürband Glas-Wand 90° nach außen öffnend. Material: Messing.
- CR - NS

e▶ **B.228**

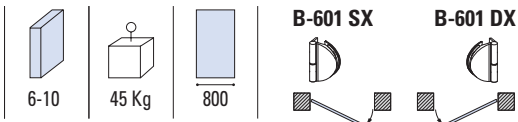
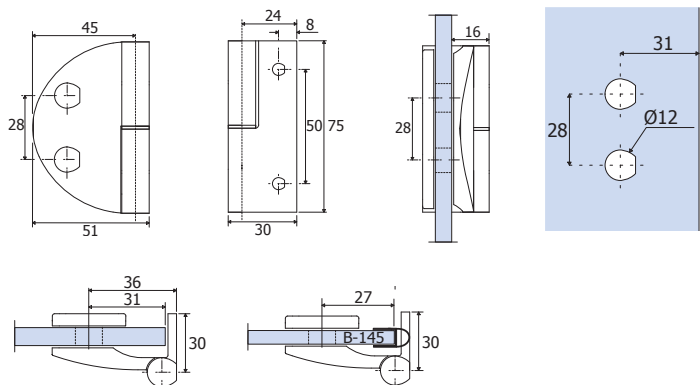

xme402



B-602 DX - SX

- Cerniera vetro/vetro apertura a tirare. Materiale: ottone.
 - Glass to glass hinge pull to open. Material: brass.
 - Duschtürband Glas-Wand nach außen öffnend. Material: Messing.
- CR - NS

e▶ **B.229**

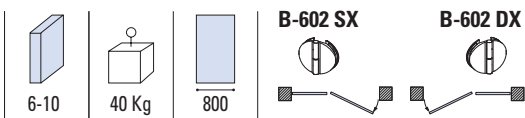
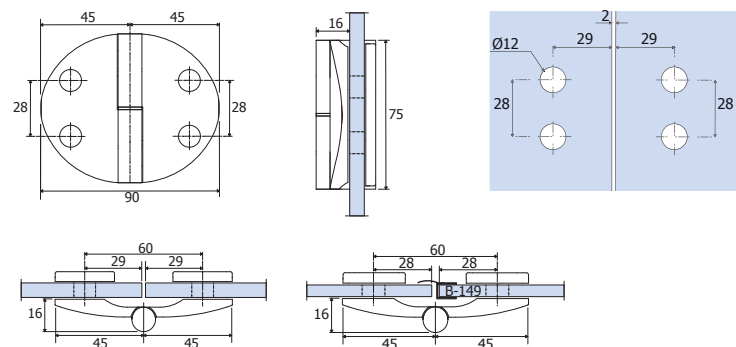

xme402

CR
Cromo lucido
Polished chrome
Chrom glänzend

NS
Nickel satinato
Satin nickel
Ähnlich Edelstahl matt



CERNIERE

BX-2100 BILICO



CERNIERE

- Sistema per box doccia tutto vetro con cerniere Bilico per porte pivotanti. Materiale: alluminio finitura cromo lucido.
- Frameless glass shower system with Bilico hinges for pivot doors. Material: aluminium Polished Chrome.
- Rahmenlose Duschkabinesystem aus Glas mit Bilico Bänder für Drehtüren. Material: Aluminium Chrom poliert.

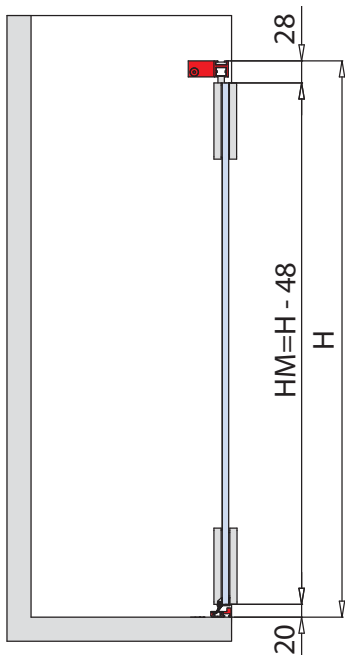

CERNIERE

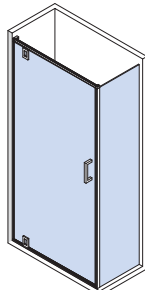
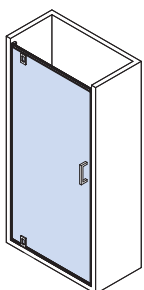
SET 1 [e► B.190](#)
SET 4 [e► B.191](#)

BX-2100 BILICO



CERNIERE

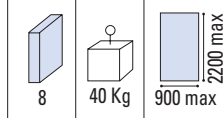
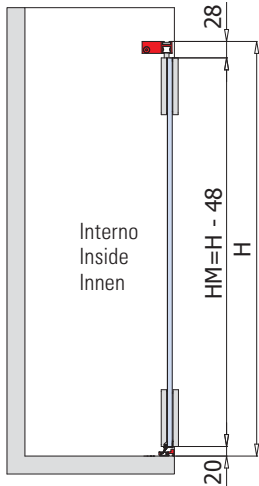

Fin. / Fin. / Oberf.
CR
Cromo lucido
Polished chrome
Chrom glänzend

Profili vetro fisso
Profiles for fixed panels
Profil für Festverglasung...▶ 140

COMPONENTI / COMPONENTS / EINZELTEILE



BX-2100 SET 2

e▶ B.190

DOCCIA IN NICCHIA / NICHE SHOWER / NISCHENDUSCHE

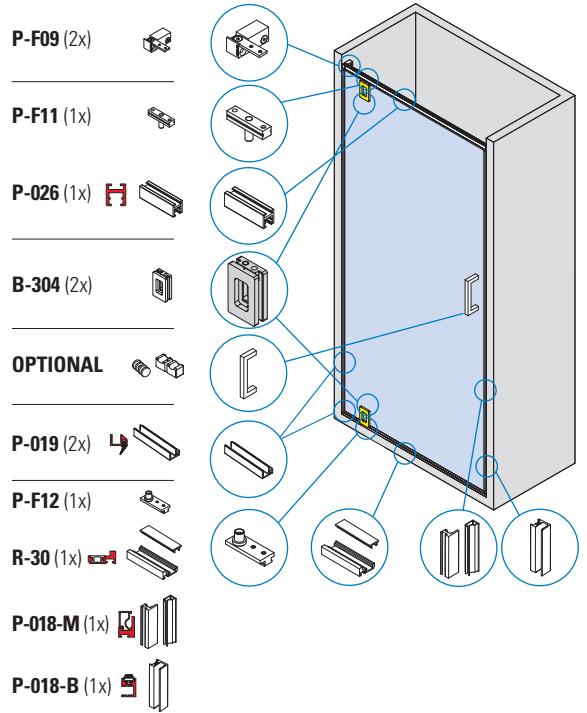

xme294-1

BX-2100 SET 4

e▶ B.191

DOCCIA CON SPALLA IN VETRO / CORNER SHOWER WITH 2
FIXED PANEL / ECKDUSCHE MIT 2 FESTSTEHENDEN GLASTAFELN

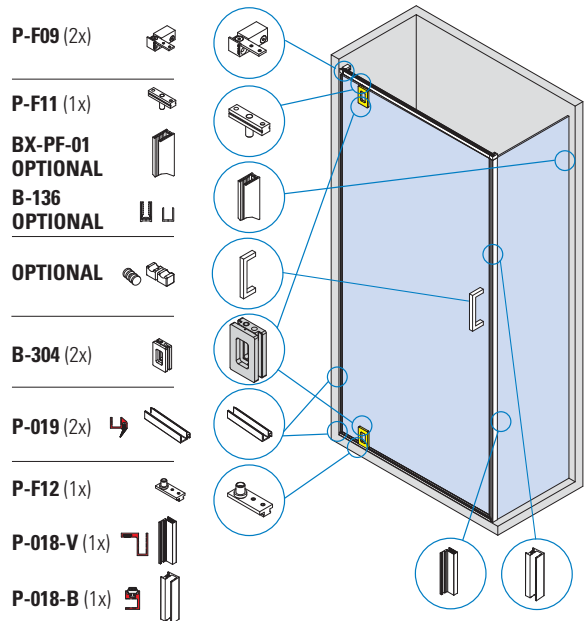

xme294-3

HV = H - 48
 LV = LP - 15

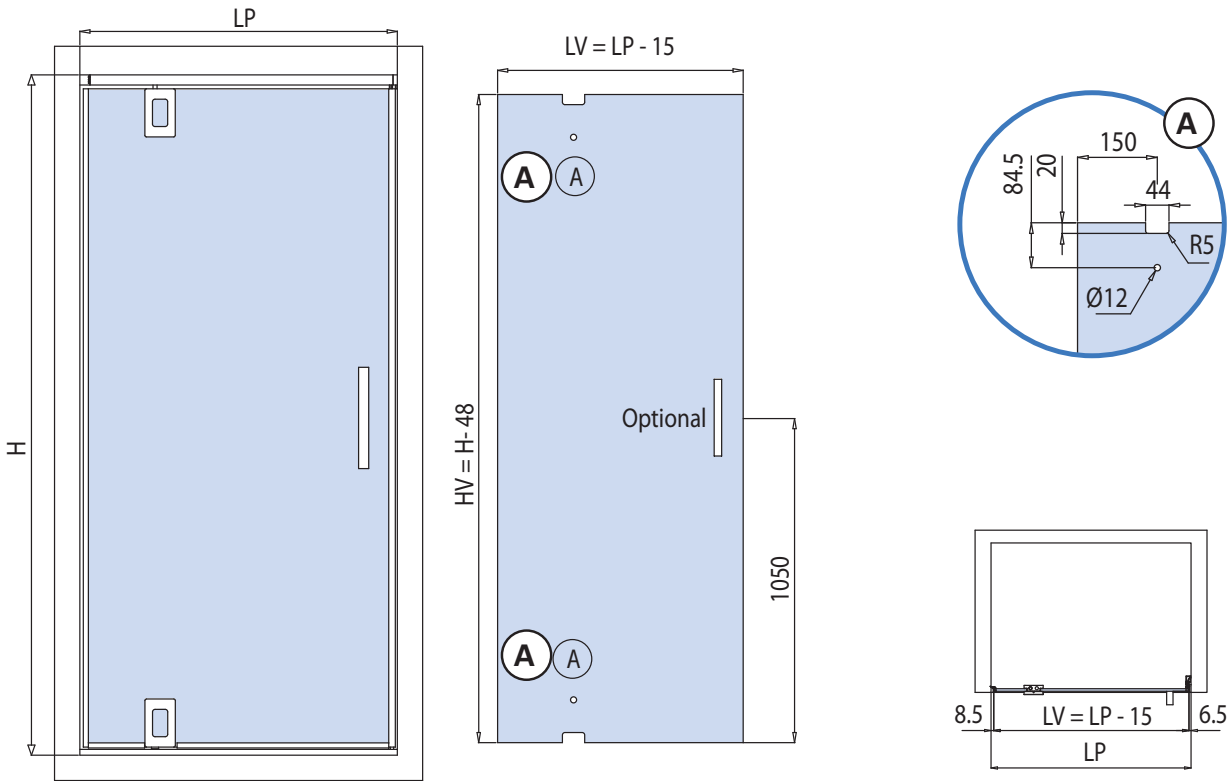

CERNIERE

HV = H - 48
 LM = LP - 36
 HF = H - 22
 LF = LP - 28

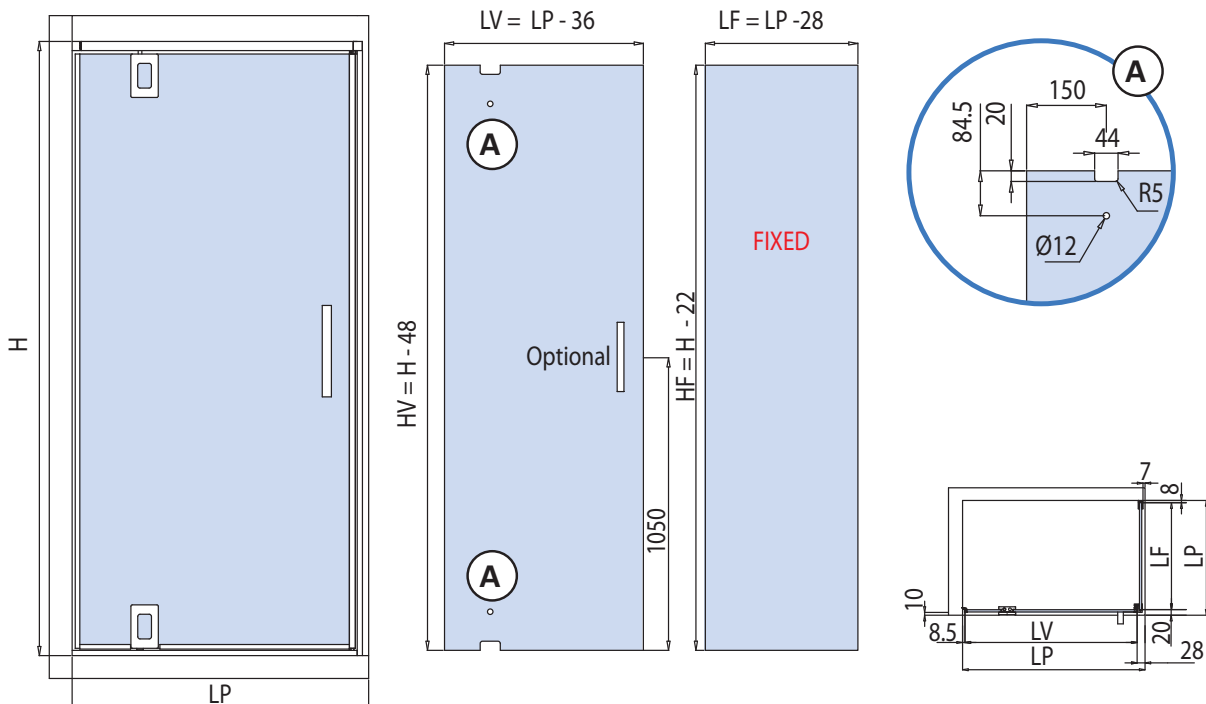

xme388

L / LP
 Piatto
 Shower tray
 Duschtaße

LF
 Larghezza vetro fisso
 Side fixed glass width
 Seitenteil Breite

LV
 Larghezza vetro mobile
 Sliding glass width
 Schiebeflügel Breite

HM
 Altezza vetro mobile
 Sliding glass height
 Schiebeflügel Höhe

H
 Altezza doccia
 Shower height
 Duschkabinen Höhe

HF
 Altezza vetro fisso
 Side fixed glass height
 Seitenteil Höhe

BX-2100 BILICO

COMPONENTI / COMPONENTS / EINZELTEILE

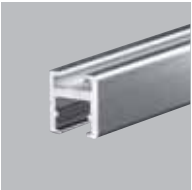

P-026 ▶ **B.193**

- Binario
- Track profile
- Laufschiene

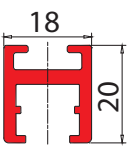

Cod.	Fin./Fin./Oberf.
P-026-1000 mm	CR

xfb-062



P-018-M ▶ **B.194**

- Profilo battuta a muro per porta battente compreso di magnete
- Door stop profile for hinged door, with magnetic gasket
- Türanschlagsprofil mit Magnet Dichtung

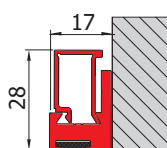

Cod.	Fin./Fin./Oberf.
P-018-M-2200 mm	CR

xme-305



P-018-B ▶ **B.193**

- Profilo bordo vetro con magnete per chiusura a battuta con profilo P-018-M o P-018-V
- Closure profile with magnetic seal for profiles P-018-M or P-018-V
- Vertikal Rahmenprofil für Magnetische Zuhaltung mit Profile P-018-M oder P-018-V

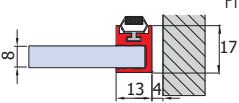

Cod.	Fin./Fin./Oberf.
P-018-B-2200 mm	CR

xme-305



P-018-V ▶ **B.196**

- Profilo battuta a vetro per porta battente compreso di magnete
- Door stop profile glass installation for hinged door, with magnetic gasket
- Türanschlagsprofil Glasmontage mit Magnet Dichtung

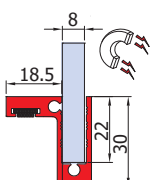

Cod.	Fin./Fin./Oberf.
P-018-V-2200 mm	CR

xme-305

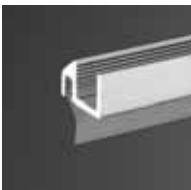

P-019 ▶ **B.197**

- Profilo gocciolatoio con guarnizione in PVC trasparente da 9 mm
- Splash guard profile with drip flat 9 mm seal transparent PVC
- Schwallenschutz Profil mit trasparent PVC Dichtung 9 mm

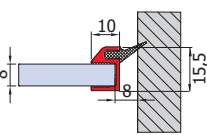

Cod.	Fin./Fin./Oberf.
P-019-2200 mm	CR

xme-305



R-30 ▶ **B.198**

- Profilo a terra
- Floor profile
- Bodenprofil

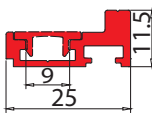

Cod.	Fin./Fin./Oberf.
R-30-1000 mm	CR

xfb-063



B-304 ▶ **B.199**

- Cerniera alto/basso in abbinamento a kit BX-2100
- Top/bottom hinge, component of BX-2100
- Oberes / unteres Band, Einzelteile BX-2100 CR



xfb-063



P-F09 ▶ **B.202**

- Attacco a parete per binario
- Wall connector for track profile
- Wandhalter für Laufschiene

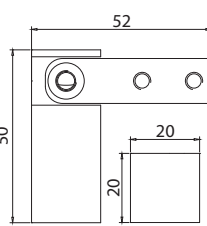

xfb-063



P-F13 ▶ **B.203**

- Attacco a vetro per binario
- Glass connector for track profile
- Glashalter für Laufschiene

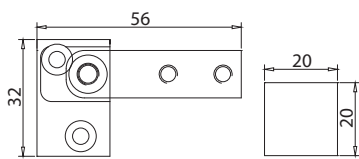

xfb-063



P-F11 ▶ **B.200**

- Perno superiore in abbinamento a binario P-026
- Top pin for track profile P-026
- Oberer Zapfen für Laufschiene P-026

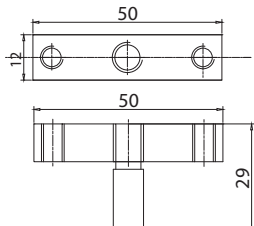

xfb-063



P-F12 ▶ **B.201**

- Perno inferiore in abbinamento a profilo a terra R-30
- Bottom pin for floor profile R-30
- Unterer Zapfen für Bodenprofil R-30

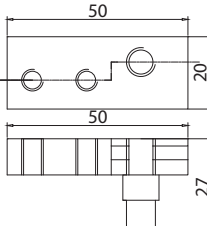

xfb-063

CERNIERE



CERNIERE

B-305

PIVOT ALTO/BASSO (BILICO) / TOP/BOTTOM PIVOT HINGES / OBERE/UNTERE PIVOT BÄNDER

- Sistema per box doccia tutto vetro con cerniera a scatto alto/basso, regolabile, senza vetri a vista.
- Frameless glass showers systems with adjustable pivot clicking hinges, with not visible screws.
- Rahmenlose Duschkabinesystem aus Glas mit oberem/unterem Band, mit Nullageverstellung, ohne sichtbare Schrauben.

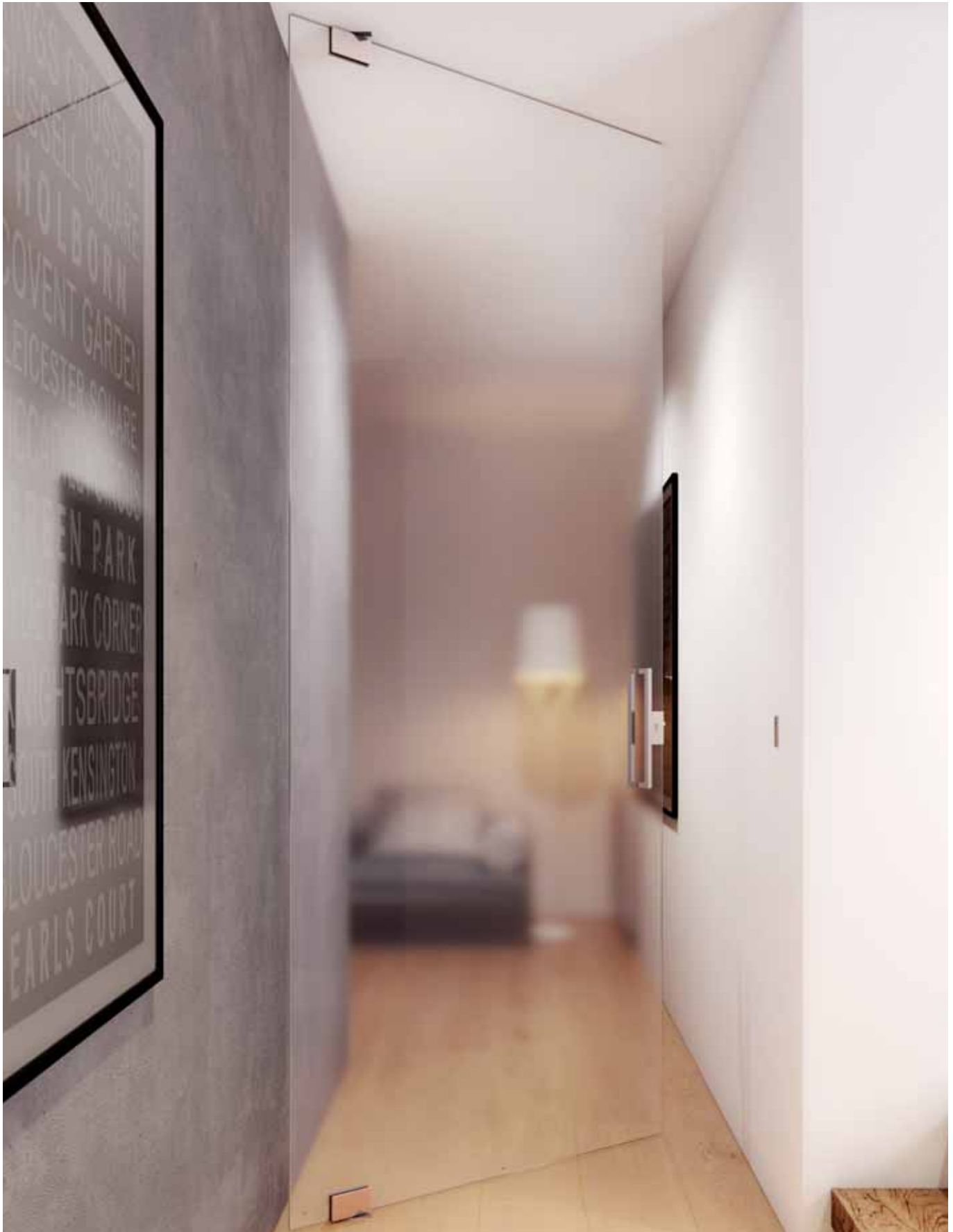

CERNIERE

B-305

 e▶ **B.206**

- Cerniera a scatto alto/basso, regolabile, senza viti a vista. Materiale: ottone
 - Adjustable pivot clicking hinge, with not visible screws. Material: Brass
 - Oberes/unteres Band, mit Nulllageverstellung, ohne sichtbare Schrauben. Material: Messing
- CR - NS - CP

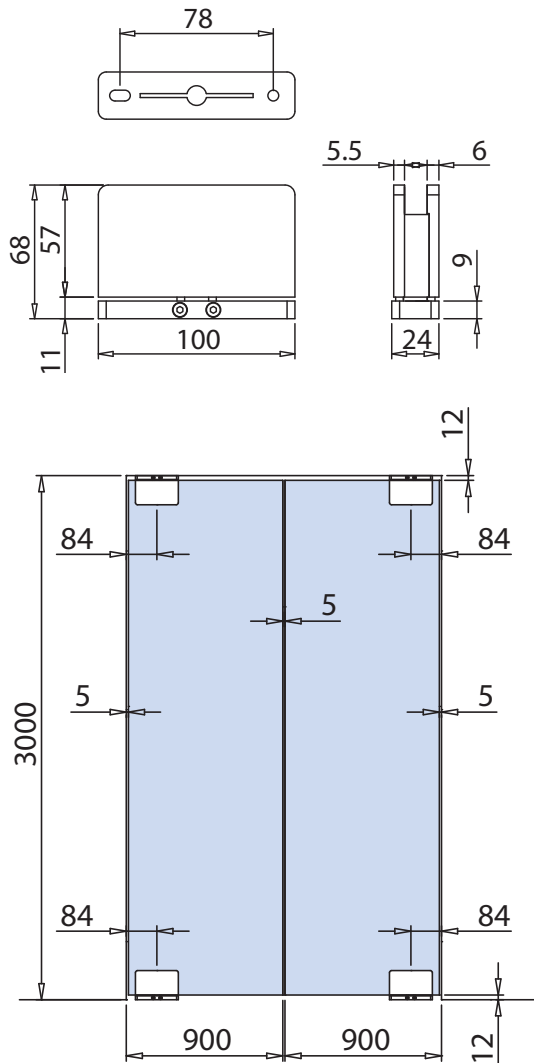
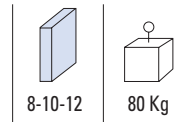
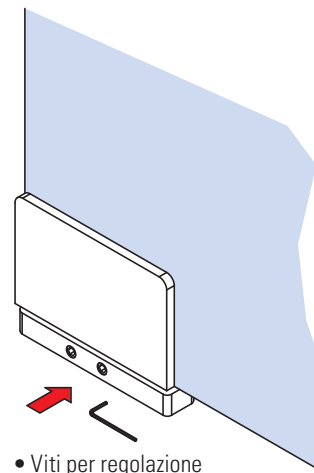
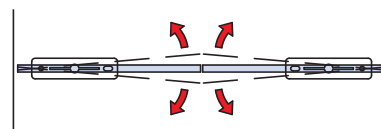
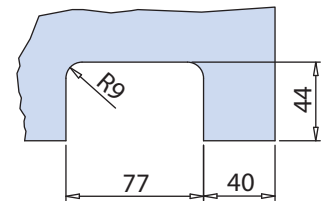
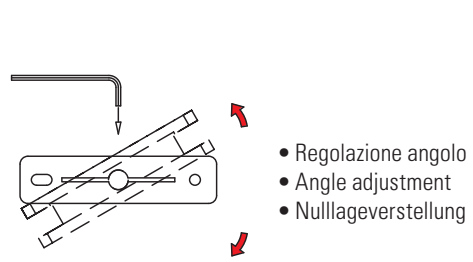
 LAVORAZIONE VETRO
 GLASS PREPARATION
 GLASBEARBEITUNG

CERNIERE

xfb085

CR
 Cromo lucido
 Polished chrome
 Chrom glänzend



NS
 Nickel satinato
 Satin nickel
 Ähnlich Edelstahl matt

CP
 Cromo perla
 Chrome perla similar Alu
 Chrom perla ähnlich Alu

B-303 BILICA

e▶ B.214

DOCCIA IN NICCHIA / NICHE SHOWER / NISCHENDUSCHE

 6-8	 35 Kg	 2000 max 800 max	Fin. / Fin. / Oberf. CR Cromo lucido Polished chrome Chrom glänzend
--	--	--	---



CERNIERE

- Sistema per box doccia tutto vetro con cerniere Bilica per porte pivotanti.
- Frameless glass shower system with adjustable Bilica clicking hinges for pivot doors.
- Rahmenlose Duschkabinesystem aus Glas mit Bilica Bänder für Drehtüren.

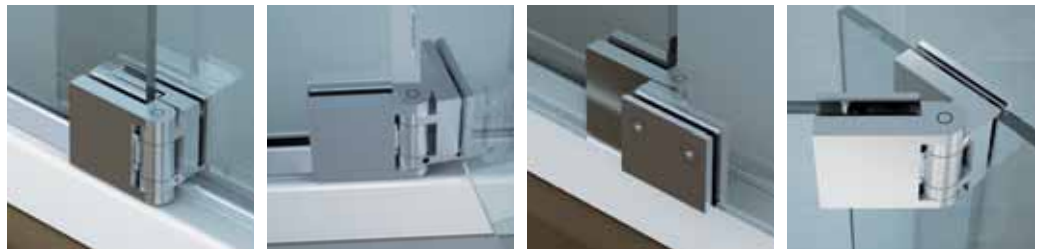

ALCUNE TIPOLOGIE DI APPLICAZIONE / SOME APPLICATION TYPOLOGIES / EINIGEN KOMPOSITIONSMÖGLICHKEITEN DES SYSTEM

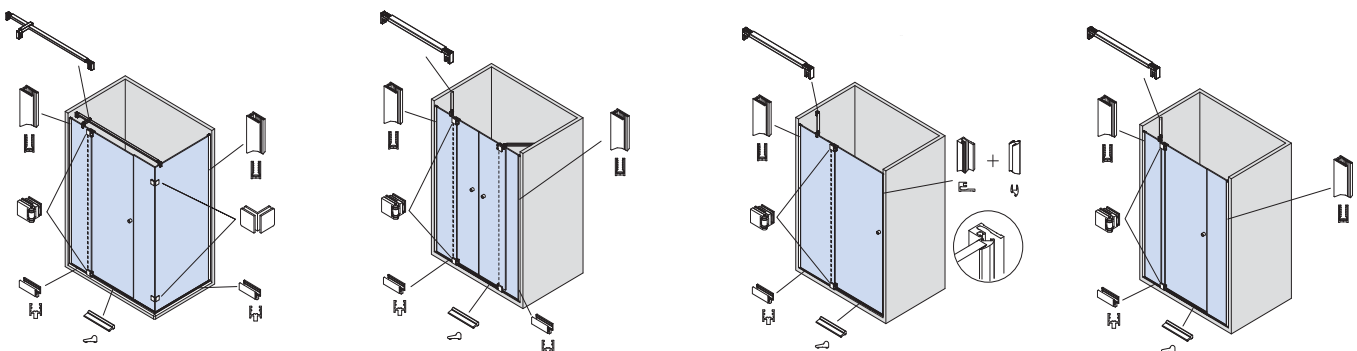

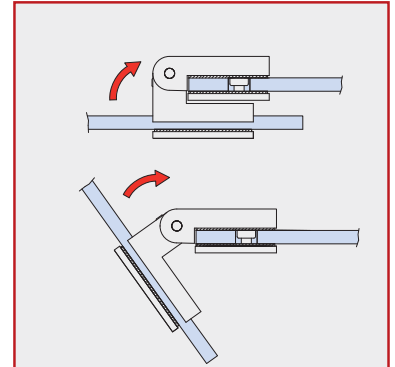
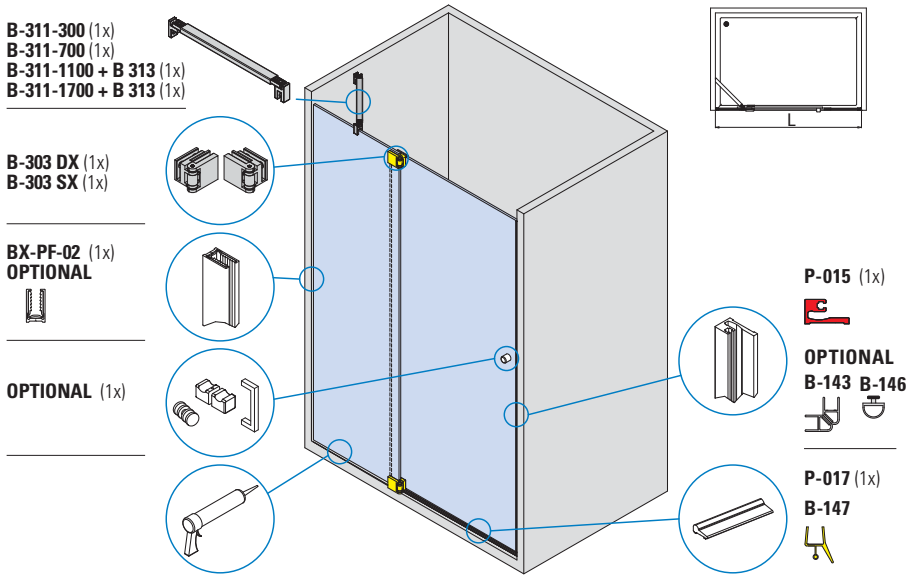
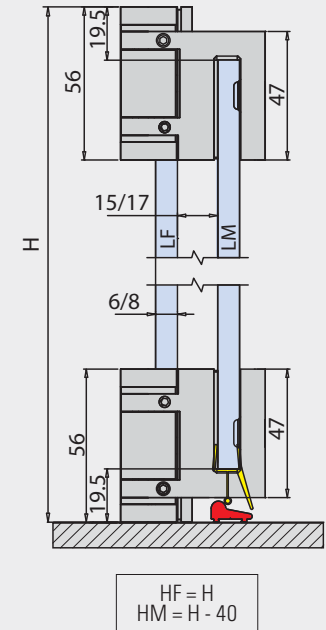
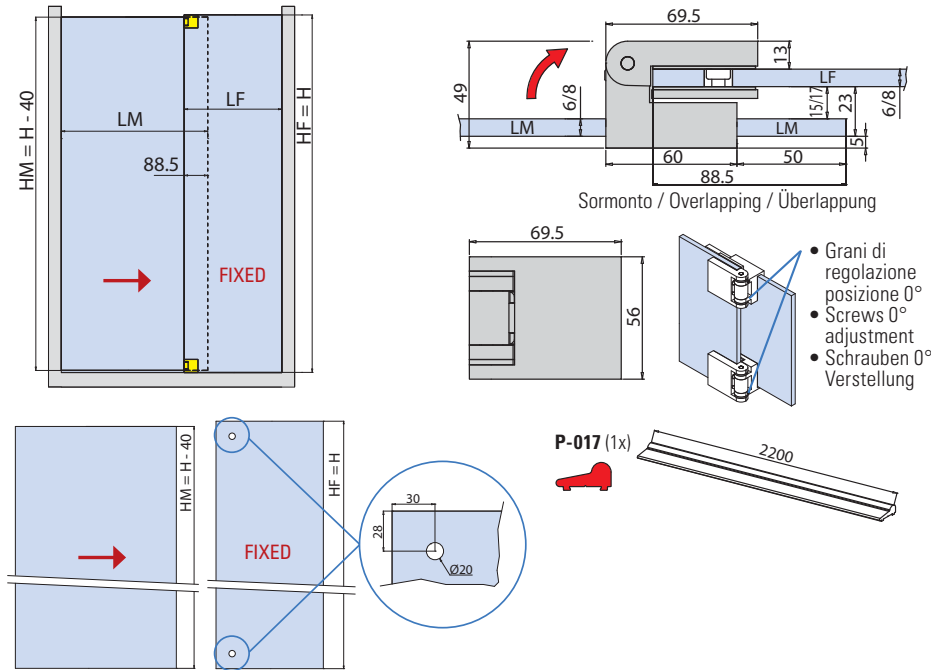
COMPONENTI / COMPONENTS / EINZELTEILE

LAVORAZIONE VETRO / GLASS PREPARATION / GLASBEARBEITUNG

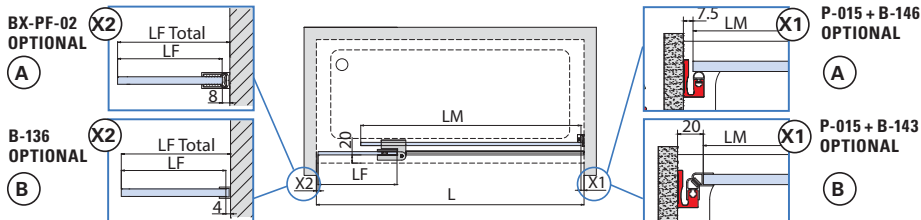
CERNIERE

CALCOLO VETRO / CALCULATION GLASS / GLASBERECHNUNG

LF Total = decisione cliente / by customer / Kundenentscheidung
 $LM = (L - LF \text{ Total}) + 88,5$
 $LM = LM - X1 (A / B)$
 $LF = LF \text{ Total} - X2 (A / B)$
 A/B = Variabile in base ai profili optional scelti /
 variable according to the optional profiles / variabel je nach optional Profile

xmc073 / xme232-1

OPTIONAL

L Piatto Shower tray Duschtaße	LM Larghezza vetro mobile Sliding glass width Schiebeflügel Breite	LF Larghezza vetro fisso Side fixed glass width Seitenteil Breite	HM Altezza vetro mobile Sliding glass height Schiebeflügel Höhe	HF Altezza vetro fisso Side fixed glass height Seitenteil Höhe	H Altezza doccia Shower height Duschkabinen Höhe
--	--	---	---	--	--

PROFILI

PROFILES / PROFILE

- PROFILI BATTUTA
- DOOR STOP PROFILES
- TÜRANSCHLAGSPROFILE



P-015 / P-015 -M
P-016 / P-018-M
P-018-B / P-018-V

▶ 134 - 135

- PROFILI GOCCIOLATOIO
- SPLASH GUARD PROFILE
- SCHWALLSCHUTZ PROFILE



P-019 / P-017

▶ 136

- PROFILO BORDO VETRO
- CLOSURE PROFILE
- VERTIKAL RAHMENPROFIL



P-027 / P-027-M

▶ 137

- PROFILI A TERRA
- FLOOR PROFILES
- BODENPROFILE

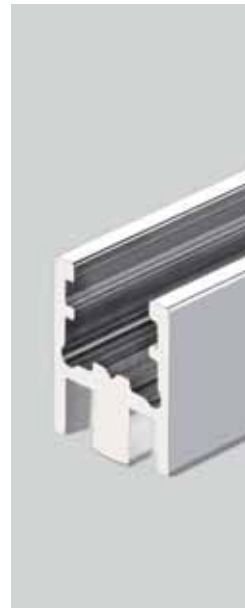

BX-PT-C58
BX-PT-C56
BX-PT-C57
BX-PT-C51
BX-PT-C52
BX-PT-C60
BX-PT-C50
BX-3150
BX-4050
BX-PT2-C50
P-017
BX-PT3-C57
BX-PT3-C60
BX-PT3-C50

▶ 138 - 139

- CANALINE "U"
- U PROFILES
- U-PROFILE



V-2036 / V-2036-T
V-2037 / V-2037-T
V-2038 / V-2038-T
V-2039 / V-2039-T
V-2040 / V-2040-T
V-2041 / V-2041-T
B-138 / B-137 / B-136
BX-PT-C58
BX-PT-C56
BX-PF-01
BX-PF-02

▶ 140 - 141

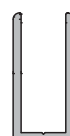

- CANALINE "U" INOX SPIGOLO VIVO
- U PROFILES IN INOX
- U-PROFILE AUS EDELSTAHL



V-2021 / V-2020
V-2016 / V-2017 / V-2019

▶ 142

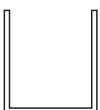

- CANALINE "U" CON BORDO RIPIEGATO
- U PROFILES WITH FOLDED EDGE
- U-PROFILE MIT ABGERUNDETER KANTE



V-2030 / V-2016-R
V-2017-R / V-2029

▶ 142

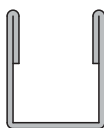

- ANGOLARI
- L PROFILES
- L-PROFILE



V-2025 / V-2024
V-2023 / V-2022

▶ 143



- CANALINE CON ALETTA
- U PROFILES WITH SIDE PLATE
- U-PROFILE MIT PLATTE



V-2028 / V-2027 / V-2026
V-2033 / V-2032 / V-2031

▶ 143

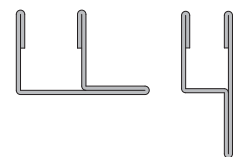

PROFILI

PROFILI BATTUTA DOOR STOP PROFILES / TÜRANSCHLAGSPROFILE

► B.230



P-015 / P-015-M

- Profilo battuta a muro per porta battente con possibilità di applicazione guarnizione a palloncino o magnetica. Barre da 2200mm fino a esaurimento scorte. Disponibilità di barre con lunghezza da 2500 mm da verificare con ufficio commerciale.
- Door stop profile for hinged door, available for ball or magnetic gasket. Bars of 2200 mm will be discontinued. Availability of bars with length of 2500 mm to be checked with sales office.
- Türanschlagsprofil lieferbar für pvc und Magnet Dichtung. Profile in 2200 mm Länge lieferbar solange der Vorrat reicht. Die Verfügbarkeit von Profile in 2500 mm Länge ist mit dem Verkaufsbüro abzustimmen.

CR

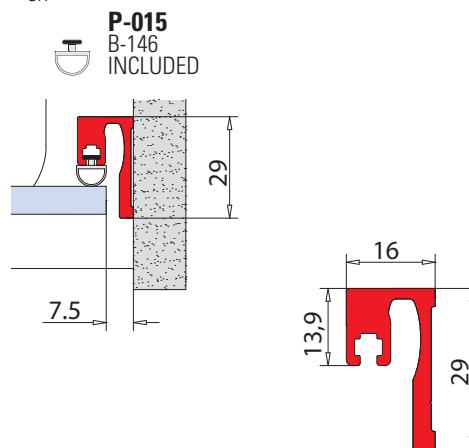

xme203

► B.231



P-016

- Profilo bordo vetro per chiusura a battuta con magnete. Barre da 2200mm fino a esaurimento scorte. Disponibilità di barre con lunghezza da 2500 mm da verificare con ufficio commerciale.
- Closure profile for magnetic seal. Bars of 2200 mm will be discontinued. Availability of bars with length of 2500 mm to be checked with sales office.
- Vertikal Rahmenprofil für Magnetische Zuhaltung. Profile in 2200 mm Länge lieferbar solange der Vorrat reicht. Die Verfügbarkeit von Profile in 2500 mm Länge ist mit dem Verkaufsbüro abzustimmen.

CR

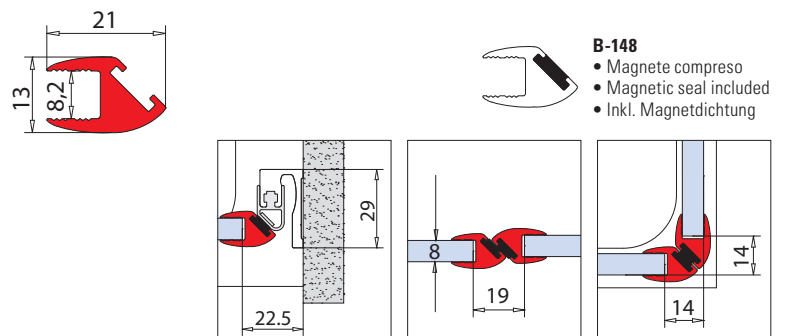

xme203

P-018-M

e▶ B.232

- Profilo battuta a muro per porta battente compreso di magnete. Barre da 2200mm fino a esaurimento scorte. Disponibilità di barre con lunghezza da 2500 mm da verificare con ufficio commerciale.
- Door stop profile for hinged door, with magnetic gasket. Bars of 2200 mm will be discontinued. Availability of bars with length of 2500 mm to be checked with sales office.
- Türanschlagsprofil mit Magnet Dichtung. Profile in 2200 mm Länge lieferbar solange der Vorrat reicht. Die Verfügbarkeit von Profile in 2500 mm Länge ist mit dem Verkaufsbüro abzustimmen.

CR

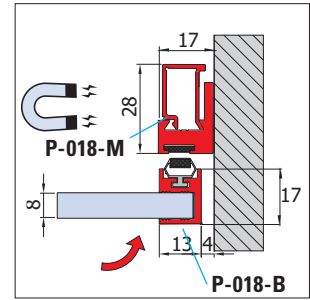

xme305

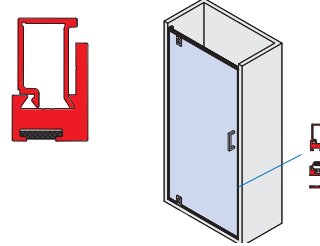
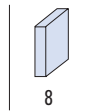
P-018-B

e▶ B.233

- Profilo bordo vetro con magnete, per chiusura a battuta. Barre da 2200mm fino a esaurimento scorte. Disponibilità di barre con lunghezza da 2500 mm da verificare con ufficio commerciale.
- Closure profile with magnetic seal for profiles. Bars of 2200 mm will be discontinued. Availability of bars with length of 2500 mm to be checked with sales office.
- Vertikal Rahmenprofil für Magnetische Zuhaltung. Profile in 2200 mm Länge lieferbar solange der Vorrat reicht. Die Verfügbarkeit von Profile in 2500 mm Länge ist mit dem Verkaufsbüro abzustimmen.

CR

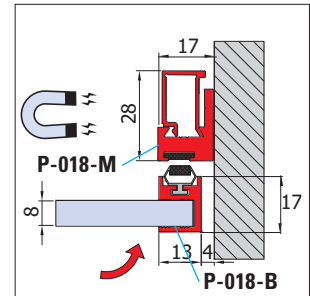

xme305

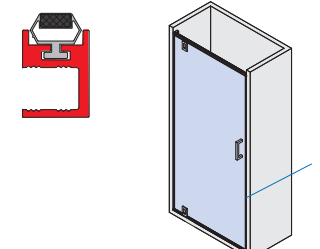
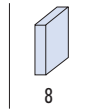
P-018-V

e▶ B.234

- Profilo battuta a vetro per porta battente compreso di magnete. Barre da 2200mm fino a esaurimento scorte. Disponibilità di barre con lunghezza da 2500 mm da verificare con ufficio commerciale.
- Door stop profile glass installation for hinged door, with magnetic gasket. Bars of 2200 mm will be discontinued. Availability of bars with length of 2500 mm to be checked with sales office.
- Türanschlagsprofil Glasmontage mit Magnet Dichtung. Profile in 2200 mm Länge lieferbar solange der Vorrat reicht. Die Verfügbarkeit von Profile in 2500 mm Länge ist mit dem Verkaufsbüro abzustimmen.

CR

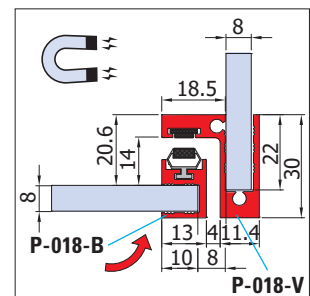

xme305

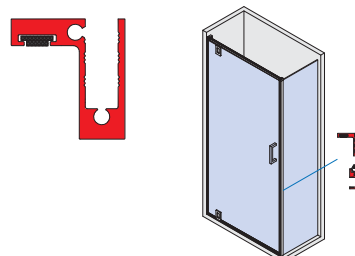
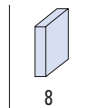
CR
 Cromo lucido
 Polished chrome
 Chrom glänzend

PROFILI GOCCIOLATOIO

SPLASH GUARD PROFILE / SCHWALLSCHUTZ PROFIL



P-019

- Profilo gocciolatoio in alluminio cromo lucido. Barre da 2200 mm fino a esaurimento scorte. Disponibilità di barre con lunghezza da 2500 mm da verificare con ufficio commerciale.
- Splash guard profile. Bars of 2200 mm will be discontinued. Availability of bars with length of 2500 mm to be checked with sales office.
- Schwallschutz Profil mit PVC Dichtung. Profile in 2200 mm Länge lieferbar solange der Vorrat reicht. Die Verfügbarkeit von Profile in 2500 mm Länge ist mit dem Verkaufsbüro abzustimmen.

CR

e▶ B.162 e▶ B.169

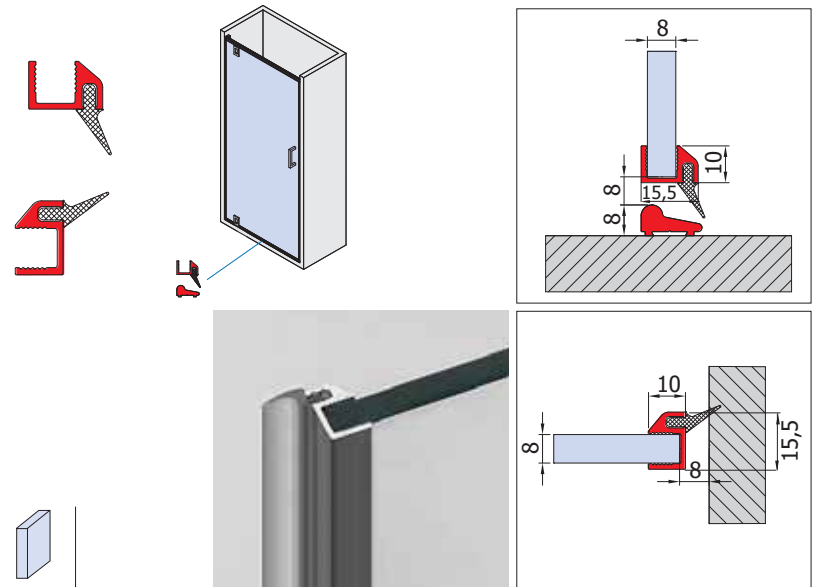

xme305



PROFILI

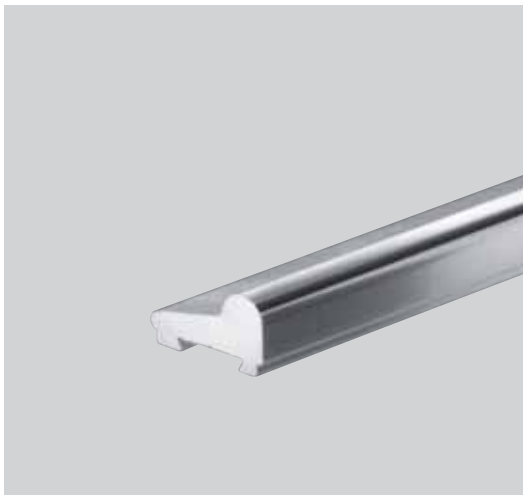

P-017

- Profilo gocciolatoio.
 - Splash guard profile.
 - Schwallchutz Profil.
- L = 2100 mm

CR

e▶ B.159

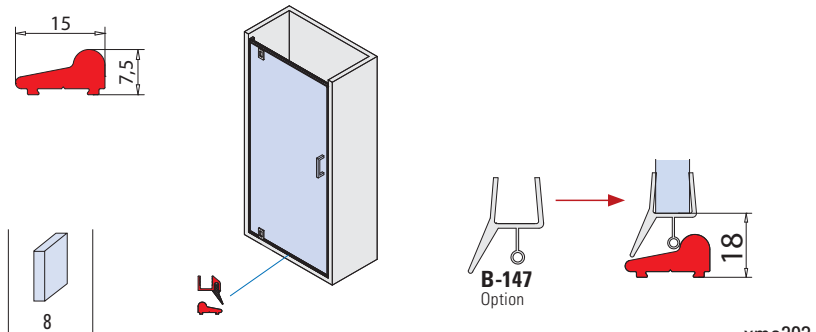

xme203



BX-PT3-C57

e▶ B.116

- Angolo 90° lato entrata doccia per profili P-017.
- Joint 90° corner entry for profiles P-017.
- 90° Verbindung Eckeinstieg für Profile P-017.

CR

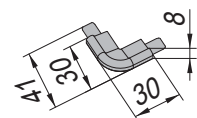

BX-PT3-C60

e▶ B.117

- Coperchietto finale per profili P-017, destro e sinistro.
- Endcap for profiles P-017, left and right.
- Endkappe für Profile P-017 Links und Rechts.

CR

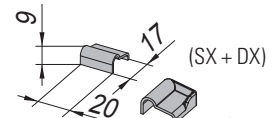

xla367c-2

CR
Cromo lucido
Polished chrome
Chrom glänzend

PROFILO BORDO VETRO

CLOSURE PROFILE / VERTIKAL RAHMENPROFIL



P-027

[e▶ B.236](#)

- Profilo bordo vetro con guarnizione a palloncino. Barre da 2200 mm fino a esaurimento scorte. Disponibilità di barre con lunghezza da 2500 mm da verificare con ufficio commerciale.
- Border profile with gasket supplied. Bars of 2200 mm will be discontinued. Availability of bars with length of 2500 mm to be checked with sales office.
- Rahmenprofil mit Dichtung. Profile in 2200 mm Länge lieferbar solange der Vorrat reicht. Die Verfügbarkeit von Profile in 2500 mm Länge ist mit dem Verkaufsbüro abzustimmen.

CR

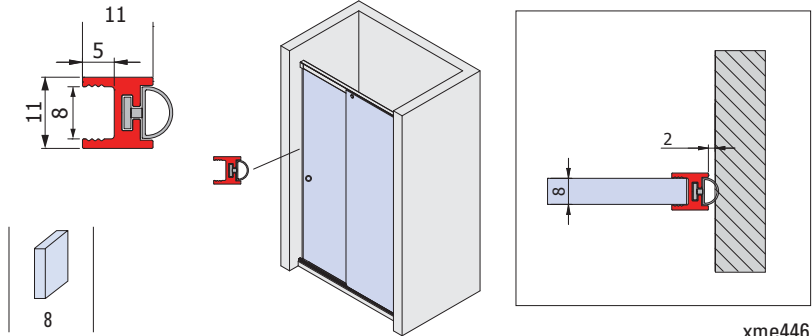

xme446



P-027-M

[e▶ B.237](#)

- Profilo magnetico bordo vetro per chiusura porta battente e vetro fisso. Barre da 2200 mm fino a esaurimento scorte. Disponibilità di barre con lunghezza da 2500 mm da verificare con ufficio commerciale.
- Closure profile for magnetic seal swing door and fixed glass. Bars of 2200 mm will be discontinued. Availability of bars with length of 2500 mm to be checked with sales office.
- Vertikal Rahmenprofil für Magnetische zu Haltung Drehtür und Festverglasung. Profile in 2200 mm Länge lieferbar solange der Vorrat reicht. Die Verfügbarkeit von Profile in 2500 mm Länge ist mit dem Verkaufsbüro abzustimmen.

CR

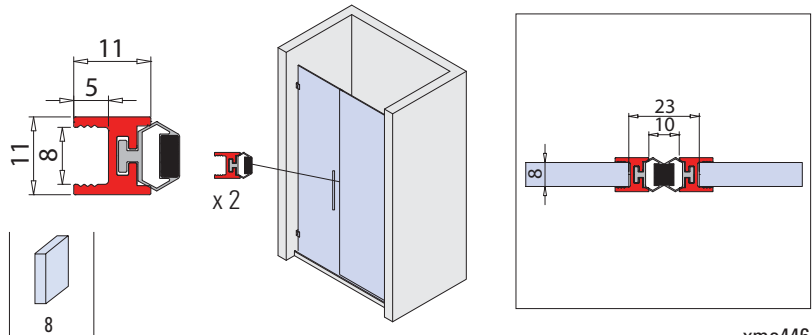

xme446



PROFILI

PROFILI A TERRA

FLOOR PROFILES / BODENPROFILE

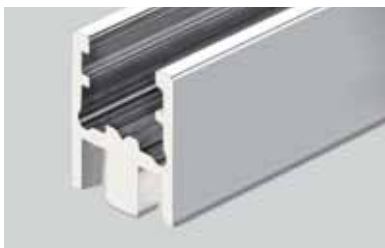

BX-PT-C58

- Profilo a terra.
- Floor profile.
- Bodenprofil.

CR - NO



Cod.	Fin./Fin./Fin.
BX-PT-C58-1500 mm	CR / NO
BX-PT-C58-3000 mm	CR / NO

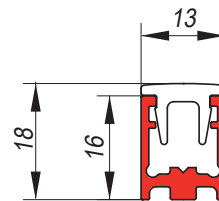

e▶ B.101

xla367b



BX-PT-C56

- Coperchio per profilo a terra per tratto entrata doccia.
- Cover profile for floor profile, shower entry.
- Profilabdeckung Bodenprofil, Duscheinstieg.

CR - NO

Cod.	Fin./Fin./Fin.
BX-PT-C56-1500 mm	CR / NO
BX-PT-C56-3000 mm	CR / NO

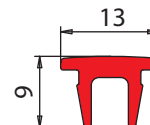

e▶ B.102

xla308



BX-PT-C57

- Angolo 90° lato entrata doccia ad angolo per profili BX-PT-C58 / BX-PT-C56.
- Joint 90° corner entry for profiles BX-PT-C58 / BX-PT-C56.
- 90° Verbindung EckEinstieg für Profile BX-PT-C58 / BX-PT-C56.

CR - NO

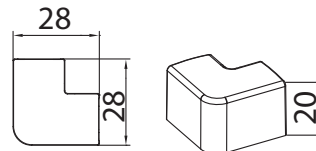

e▶ B.109

xla306



BX-PT-C51

- Angolo 90° vetro fisso/vetro fisso per profilo BX-PT-C58.
- Joint 90° fixed/fixed glass for profile BX-PT-C58.
- 90° Verbindung 2 Festverglasungen für Profil BX-PT-C58.

CR - NO

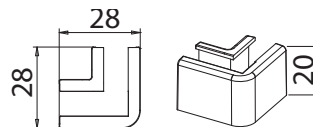

e▶ B.111

xla308



BX-PT-C52- DX / BX-PT-C52 SX

- Angolo 90° per lato entrata doccia e lato vetro fisso dx e sx per profili BX-PT-C58 / BX-PT-C56.
- Joint 90° entry and fixed glass, left and right for profiles BX-PT-C58 / BX-PT-C56.
- 90° Verbindung Einstieg-Festverglasung, Links und Rechts für Profile BX-PT-C58 / BX-PT-C56.

CR - NO

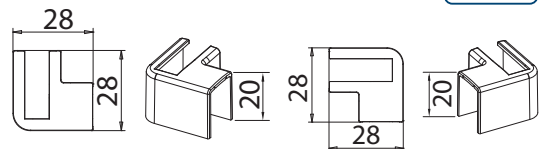

e▶ B.112

xla308



BX-PT-C60

- Coperchietto finale per profili BX-PT-C58 / BX-PT-C56.
- Endcap for profiles BX-PT-C58 / BX-PT-C56.
- Endkappe für Profile BX-PT-C58 / BX-PT-C56.

CR - NO

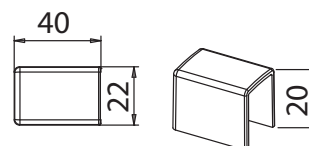

e▶ B.110

xla307

BX-PT-C50

- Guida vetro scorrevole per applicazione con profilo a terra.
 - Floor guide sliding panel for installation with floor profile.
 - Schiebetür Bodenführung für Montage mit Bodenprofile.
- CR - NO

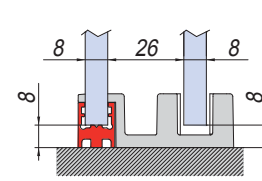
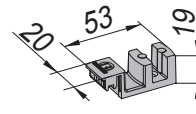

HM = H - 8
HF = H - 8

e▶ B.115

xla367



BX-3150



BX-4050

BX-3150 / BX-4050

e▶ B.53 e▶ B.108

- Guida vetro scorrevole con sistema di sgancio della porta per facilitare la pulizia per applicazione con profilo a terra. BX-PT-C58
 - Floor guide sliding panel with quick release door function for easy cleaning for installation with floor profile. BX-PT-C58
 - Schiebetür Bodenführung mit auslösbarem System um das Reinigen zu erleichtern für Montage mit Bodenprofile. BX-PT-C58
- CR - NO

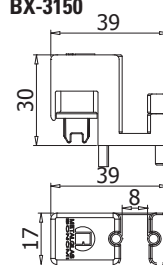
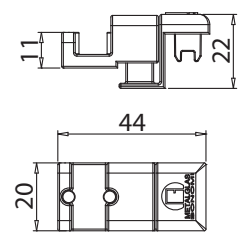
BX-3150

BX-4050

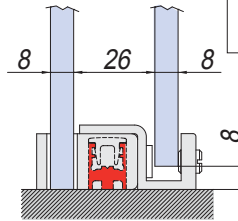
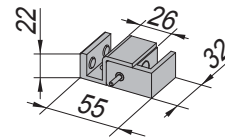
BX-PT2-C50

- Guida vetro scorrevole per applicazione con profilo a terra.
 - Floor guide sliding panel for installation with floor profile.
 - Schiebetür Bodenführung für Montage mit Bodenprofile.
- CR



HM = H - 8
HF = H

e▶ B.113

xla367b

P-017

- Profilo gocciolatoio.
 - Splash guard profile.
 - Schwallschutz Profil.
- L = 2100 mm
CR

Cod.	Fin./Fin./Oberf.
P-017-2100 mm	CR

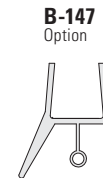
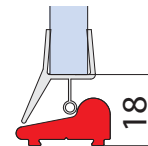
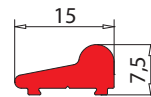

B-147
Option

e▶ B.159

xme203

BX-PT3-C57

e▶ B.116

- Angolo 90° lato entrata doccia per profili P-017.
 - Joint 90° corner entry for profiles P-017.
 - 90° Verbindung Eckeinstieg für Profile P-017.
- CR

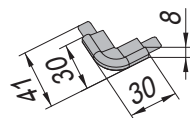

xla367c-2

BX-PT3-C60

e▶ B.117

- Coperchietto finale per profili P-017, destro e sinistro.
 - Endcap for profiles P-017, left and right.
 - Endkappe für Profile P-017 Links und Rechts.
- CR

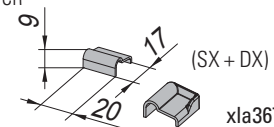

xla367c-2

BX-PT3-C50

- Guida vetro scorrevole per applicazione con profilo a terra P-017.
 - Floor guide sliding panel for installation with floor profile P-017.
 - Schiebetür Bodenführung für Montage mit Bodenprofil P-017.
- CR

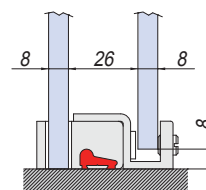
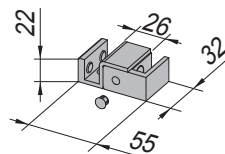

HM = H - 8
HF = H

e▶ B.115

xla367c-2

CR Cromo lucido Polished chrome Chrom glänzend	NO Nero opaco Matt black Schwarz matt
--	---

CANALINE "U"

U PROFILES / U-PROFILE



<p>V-2036 e▶ B.240</p> <ul style="list-style-type: none"> • Canalina con bordi arrotondati. • "U" channel. • U-Profil Aluminium. L = 3000 mm <p>CR - IXE - AN</p>	<p>V-2037 e▶ B.241</p> <ul style="list-style-type: none"> • Canalina con bordi arrotondati. • "U" channel. • U-Profil Aluminium. L = 3000 mm <p>CR - IXE - AN</p>	<p>V-2038 e▶ B.242</p> <ul style="list-style-type: none"> • Canalina con bordi arrotondati. • "U" channel. • U-Profil Aluminium. L = 3000 mm <p>CR - IXE - AN</p>	<p>V-2039 e▶ B.243</p> <ul style="list-style-type: none"> • Canalina con bordi arrotondati. • "U" channel. • U-Profil Aluminium. L = 3000 mm <p>CR - IXE - AN</p>	<p>V-2040 e▶ B.244</p> <ul style="list-style-type: none"> • Canalina con bordi arrotondati. • "U" channel. • U-Profil Aluminium. L = 3000 mm <p>CR - IXE - AN</p>	<p>V-2041 e▶ B.245</p> <ul style="list-style-type: none"> • Canalina con bordi arrotondati. • "U" channel. • U-Profil Aluminium. L = 3000 mm <p>CR - IXE - AN</p>
<p>V-2036 -T e▶ B.240</p> <ul style="list-style-type: none"> • Tappo per profilo • Endcap • EndKappe 	<p>V-2037 -T e▶ B.241</p> <ul style="list-style-type: none"> • Tappo per profilo • Endcap • EndKappe 	<p>V-2038 -T e▶ B.242</p> <ul style="list-style-type: none"> • Tappo per profilo • Endcap • EndKappe 	<p>V-2039 -T e▶ B.243</p> <ul style="list-style-type: none"> • Tappo per profilo • Endcap • EndKappe 	<p>V-2040 -T e▶ B.244</p> <ul style="list-style-type: none"> • Tappo per profilo • Endcap • EndKappe 	<p>V-2041 -T e▶ B.245</p> <ul style="list-style-type: none"> • Tappo per profilo • Endcap • EndKappe

B-138
[e▶ B.246](#)

- Canalina spigoli vivi.
- Sharp corner "U" channel.
- U-Profil Aluminium.

L = 3000 mm

CR - AN

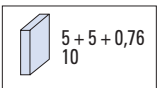
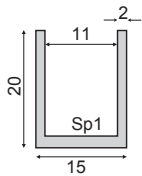
B-137
[e▶ B.247](#)

- Canalina spigoli vivi.
- Sharp corner "U" channel.
- U-Profil Aluminium.

L = 3000 mm

CR - AN

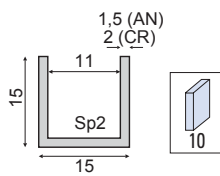
B-136
[e▶ B.248](#)

- Canalina con bordi arrotondati.
- "U" channel.
- "U"-Profil Aluminium.

L = 3000 mm

CR - NO

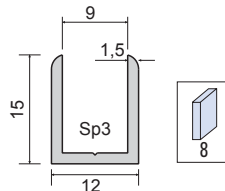

Matt Black



BX-PT-C56 (optional)



B-136-C60 (optional)

BX-PT-C58
[e▶ B.249](#)
[e▶ B.250](#)

- Profilo a terra.
- Floor profile.
- Bodenprofil.

L = 1500 / 3000 mm

CR - NO

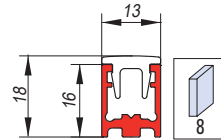
BX-PT-C56
[e▶ B.251](#)

- Coperchio per profilo a terra BX-PT-C58 per tratto entrata doccia.
- Cover profile for floor profile BX-PT-C58, shower entry.
- Profilabdeckung Bodenprofil BX-PT-C58, Duscheinstieg.

L = 1500 / 3000 mm

CR - NO

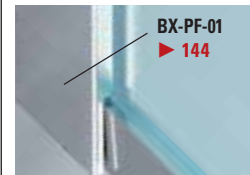
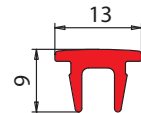
 BX-PF-01
▶ 144

 BX-PF-02
▶ 144

xla367b

xla308

CR
Cromo lucido
Polished chrome
Chrom glänzend

AN
Alluminio anodizzato
Aluminium anodized
Aluminium Silberfarbig

NO
Nero opaco
Matt black
Schwarz matt

CANALINE "U" CON BORDO A SPIGOLO VIVO L = 2500 mm U PROFILES / U-PROFILE

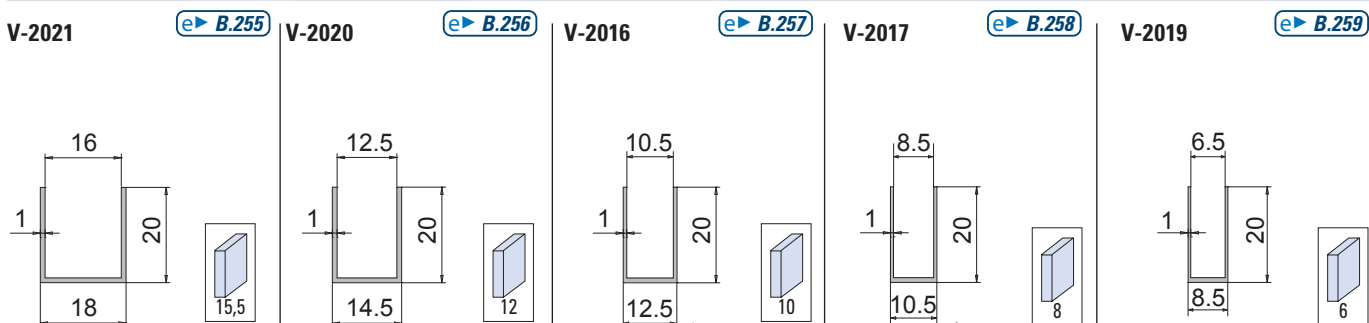
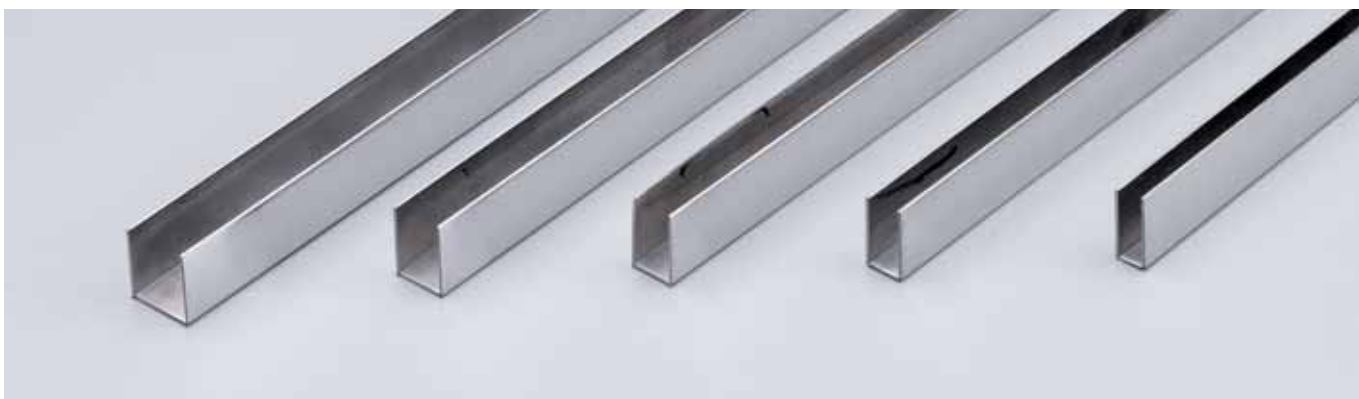

IX IL
Materiale / Material / Material
Inox AISI 304

CANALINE "U" CON BORDO RIPIEGATO L = 2500 mm U PROFILES WITH FOLDED EDGE / U-PROFILE MIT ABGERUNDETER KANTE

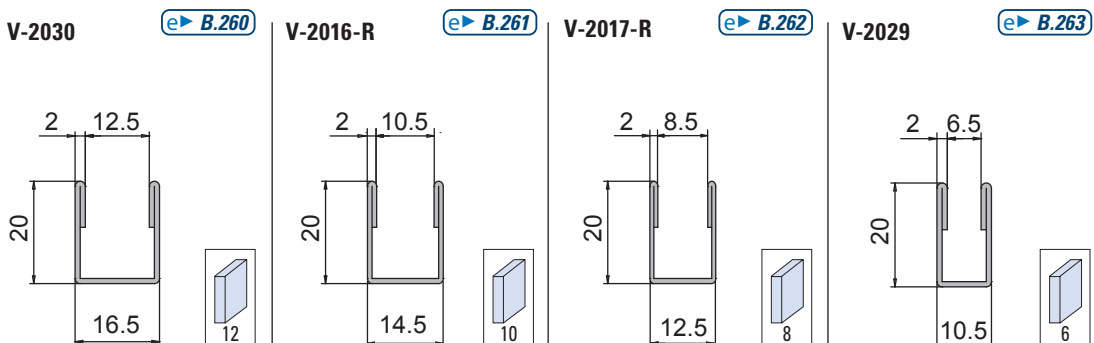

IX IL
Materiale / Material / Material
Inox AISI 304

ANGOLARI L = 2500 mm

L PROFILES / L-PROFILE

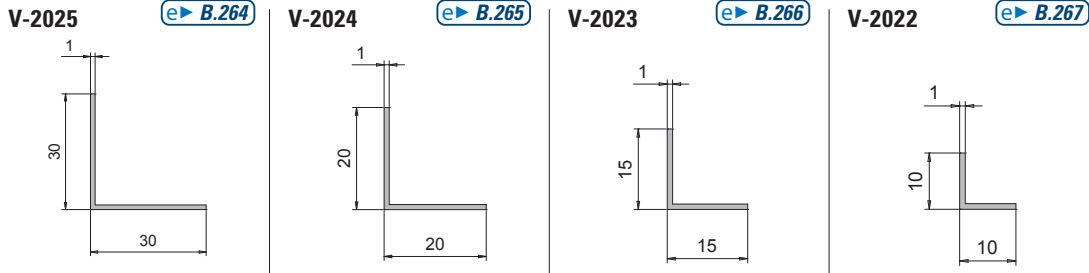

IX IL
 Materiale / Material / Material
 Inox AISI 304

CANALINE CON ALETTA LATERALE L = 2500 mm

U PROFILES WITH SIDE PLATE / U-PROFILE MIT SEITLICHER PLATTE

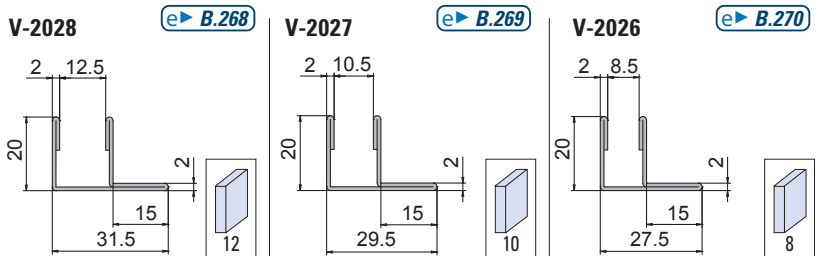

IX IL
 Materiale / Material / Material
 Inox AISI 304

CANALINE CON ALETTA L = 2500 mm

U PROFILES WITH PLATE / U-PROFILE MIT PLATTE

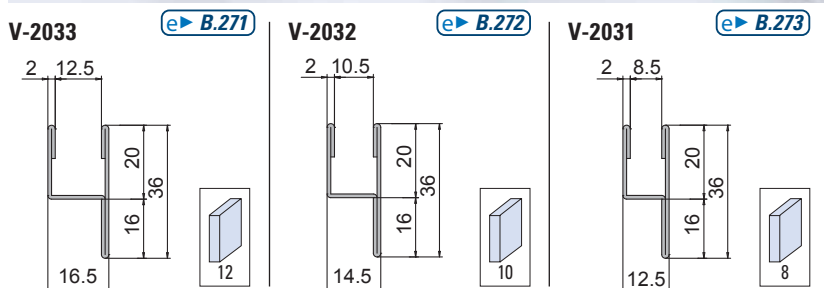

IX IL
 Materiale / Material / Material
 Inox AISI 304



CANALINE "U"

PROFILO PER FISSO A MURO CON GUARNIZIONE PROFILE WITH GASKET FOR FIXED SIDE PANEL / PROFIL FÜR SEITLICHE FESTVERGLASUNG MIT DICHTUNG

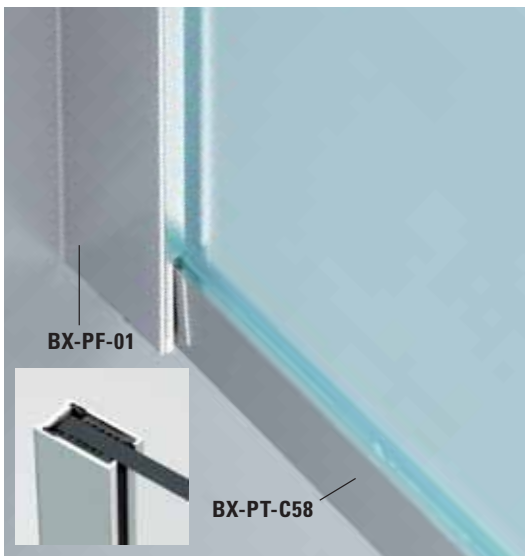

BX-PF-01

- Profilo per fisso a muro con fresatura per accoppiamento con profili a terra BX-PT-01. Barre da 2200 mm fino a esaurimento scorte. Disponibilità di barre con lunghezza da 2500 mm da verificare con ufficio commerciale.
- Profile for fixed side panel with milling for coupling with floor profiles BX-PT-01. Bars of 2200 mm will be discontinued. Availability of bars with length of 2500 mm to be checked with sales office.
- Profil für seitliche Festverglasung mit fräsung für Verbindung mit Bodenprofile BX-PT-01. Profile in 2200 mm Länge lieferbar solange der Vorrat reicht. Die Verfügbarkeit von Profile in 2500 mm Länge ist mit dem Verkaufsbüro abzustimmen.

CR - NO

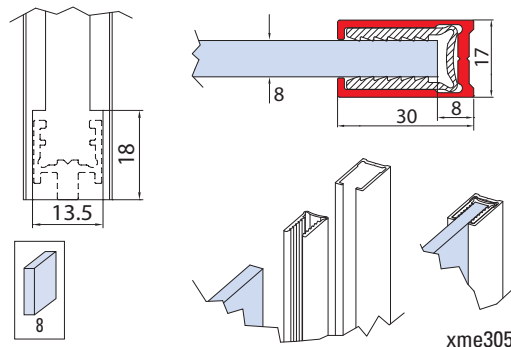

BX-PF-02

- Profilo per fisso a muro. Barre da 2200 mm fino a esaurimento scorte. Disponibilità di barre con lunghezza da 2500 mm da verificare con ufficio commerciale.
- Profile for fixed side panel. Bars of 2200 mm will be discontinued. Availability of bars with length of 2500 mm to be checked with sales office.
- Profil für seitliche Festverglasung. Profile in 2200 mm Länge lieferbar solange der Vorrat reicht. Die Verfügbarkeit von Profile in 2500 mm Länge ist mit dem Verkaufsbüro abzustimmen.

CR - NO

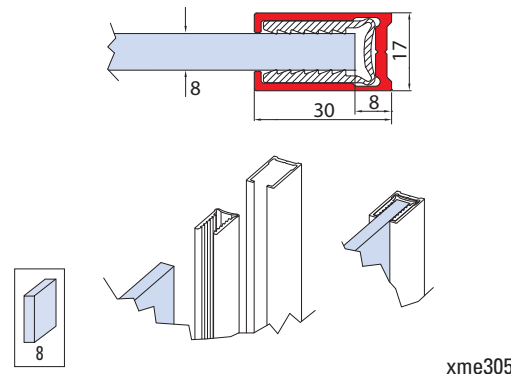

CANALINE "U"



CANALINE "U"



BOX DOCCIA SEPARÉ

SHOWERS AREA SEPARÉ
 DUSCHTRENNWAND SEPARÉ



SEPARÉ

► 148



- BARRE DI SUPPORTO QUADRE REGOLABILI
- ADJUSTABLE SQUARE SUPPORT BARS
- VERSTELTBARE ECKIGE STABILISATIONSSTANGEN

► 150



- BARRE DI SUPPORTO QUADRE
- SQUARE SUPPORT BARS
- ECKIGE STABILISATIONSSTANGEN

► 152



- BARRE DI SUPPORTO TONDE
- ROUND SUPPORT BARS
- RUNDE STABILISATIONSSTANGEN

► 155



SEPARÉ

SEPARÉ

BOX DOCCIA SEPARÉ / SHOWERS AREA SEPARÉ / DUSCHTRENNWAND SEPARÉ

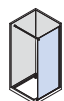
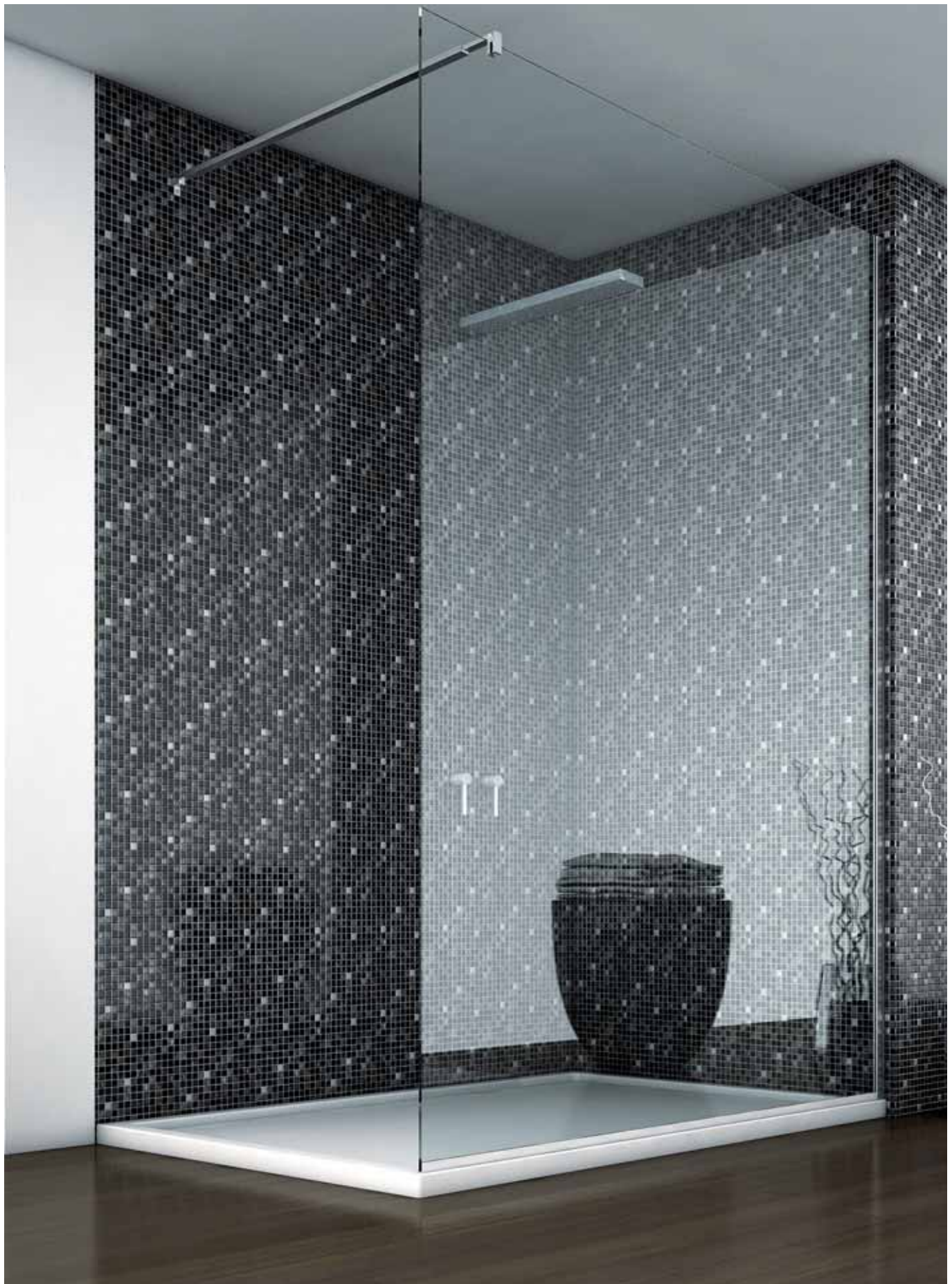

SEPARÉ

- Sistema per docce aperte tutto vetro senza porte.
- Walk-in systems for open shower areas without doors.
- Walk-in Systeme für offene Duschen ohne Türen.



- Alcune tipologie di applicazione
- Some application typologies
- Einigen kompositionsmöglichkeiten des system

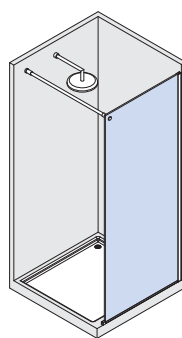
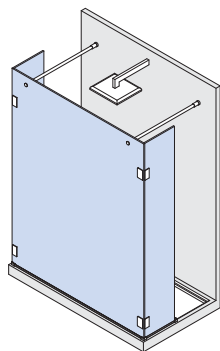
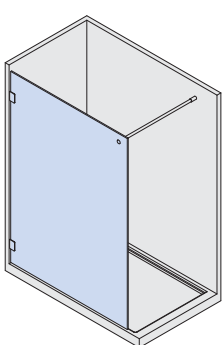

BARRE DI SUPPORTO QUADRE SNODATE SQUARE SQUARE SUPPORT BARS / ECKIGE STABILISATIONSTANGEN



Matt Black

B-328

- Barra di supporto snodata Square riducibile a piacere muro/vetro.
- Square adjustable support bar wall/glass, it is possible to cut the bar to adjust its size.
- Eckige Stabilisationsstange Wand/Glas, beliebig Kürzbar.

CR - NS - IL - NO

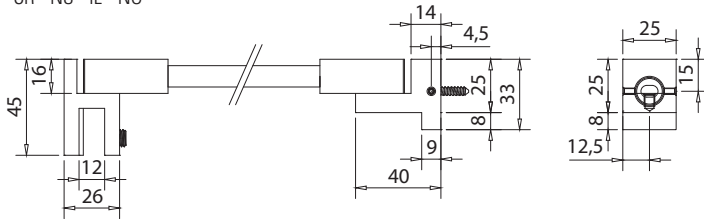

e► B.277

ART.	Lunghezza (A) Length (A) Länge (A)	Finitura Finish Oberflächen
B-328-500	500 mm	CR NS NO
B-328-1000	1000 mm	CR NS NO
B-328-1500	1500 mm	IL NO



B-328-F

- Barra di supporto snodata a muro con attacco fisso a vetro B-324.
- Square support bar with adjustable wall connector and fixed glass connector B-324.
- Eckige Stabilisationsstange Wandanschluss vestellbar, Glasanschluss fest B-324.

CR - NS - IL - NO

e► B.278

ART.	Lunghezza (A) Length (A) Länge (A)	Finitura Finish Oberflächen
B-328-F-500	500 mm	CR NS NO
B-328-F-1000	1000 mm	CR NS NO
B-328-F-1500	1500 mm	IL NO

COMPONENTI / COMPONENTS / EINZELTEILE



B-318

- Barra centrale Square riducibile a piacere.
- Square centre bar possible to cut to adjust its size.
- Eckige Stange beliebig Kürzbar.

CR - NS - IL

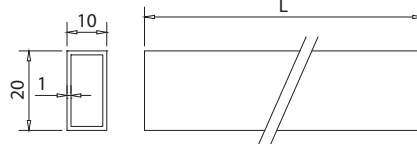

e► B.279

ART.	Lunghezza (A) Length (A) Länge (A)	Finitura Finish Oberflächen
B-318-500	500 mm	CR NS
B-318-1000	1000 mm	CR NS
B-318-1500	1500 mm	IL

xme386

CR
Cromo lucido
Polished chrome
Chrom glänzend

NS
Nickel satinato
Satin nickel
Ähnlich Edelstahl matt

IL
Acciaio inox lucido
Polished stainless steel
Edelstahl poliert

NO
Nero opaco
Matt black
Schwarz matt

B-320

- Attacco a vetro snodato per barra di supporto quadra.
- Adjustable glass connector for square support bar.
- Eckige Stabilisationsstange Glasanschluss verstellbar.

CR - NS

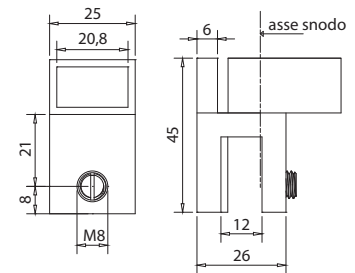

e► B.281

B-319

- Attacco a muro snodato per barra di supporto quadra.
- Adjustable wall connector for square support bar.
- Eckige Stabilisationsstange Wandanschluss verstellbar.

CR - NS

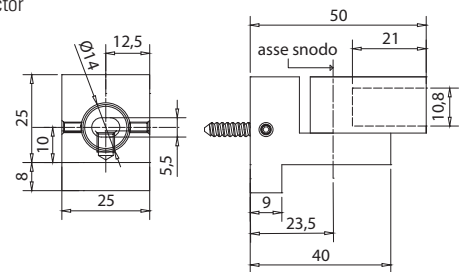

e► B.280

B-323

- Attacco a vetro chiuso per barra di supporto quadra.
- Glass connector for square support bar.
- Eckige Stabilisationsstange Glasanschluss.

CR - NS

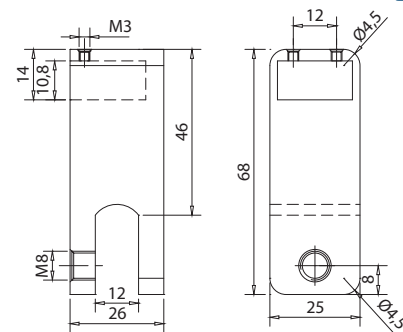

e► B.284

B-321

- Attacco a vetro 90° passante.
- Glass connector 90° for passage support bar.
- Glasanschluss 90° für Stabilisationsstange durchgehend.

CR - NS

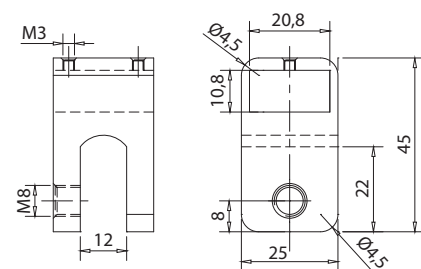

e► B.282



SEPARÉ

xme386

CR	NS
Cromo lucido	Nickel satinato
Polished chrome	Satin nickel
Chrom glänzend	Ähnlich Edelstahl matt



B-322

- Attacco a vetro in linea passante.
 - Glass connector in-line for passage support bar.
 - Glasanschluss in Linie für Stabilisationsstange durchgehend.
- CR - NS

e► B.283

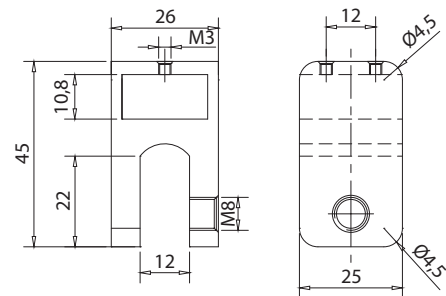

B-324

- Attacco a vetro chiuso.
 - Glass connector for square support bar.
 - Eckige Stabilisationsstange Glasanschluss.
- CR - NS

e► B.285

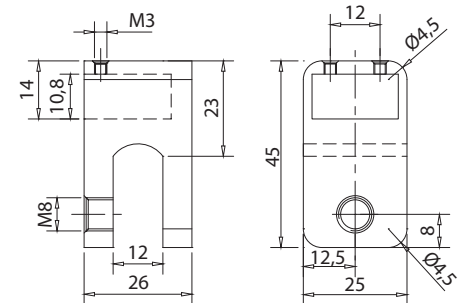

B-325

- Supporto centrale snodato per vetro fisso laterale.
 - Adjustable T-connector side glass to support bar.
 - Verstellbares T-Stück für Glas/Stange.
- CR - NS

e► B.286

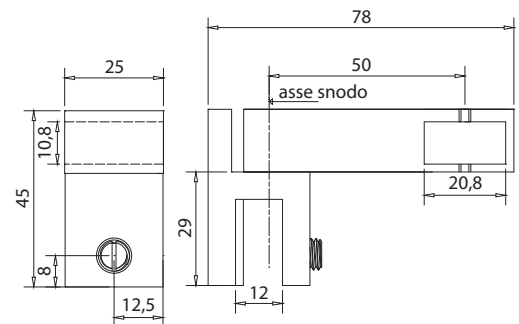

B-326

- Attacco snodato montaggio a vetro.
 - Adjustable connector for glass installation.
 - Verstellbarer Anschluss für Glasmontage.
- CR - NS

e► B.287

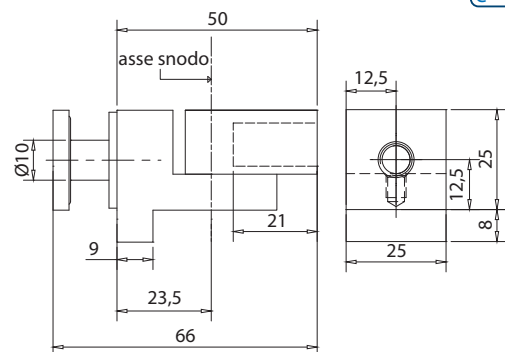

SEPARÉ

CR
Cromo lucido
Polished chrome
Chrom glänzend
152

NS
Nickel satinato
Satin nickel
Ähnlich Edelstahl matt

B-327

- Attacco snodato doppio.
 - 2-Ways adjustable connector.
 - Verstellbarer Anschluss 2-Wege
- CR - NS

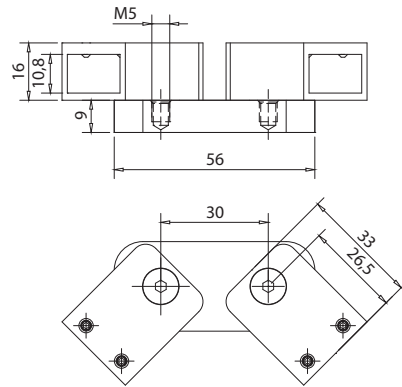
B.288

xme386



SEPARÉ

BARRE DI SUPPORTO QUADRE

SQUARE SUPPORT BARS / ECKIGE STABILISATIONSSTANGEN

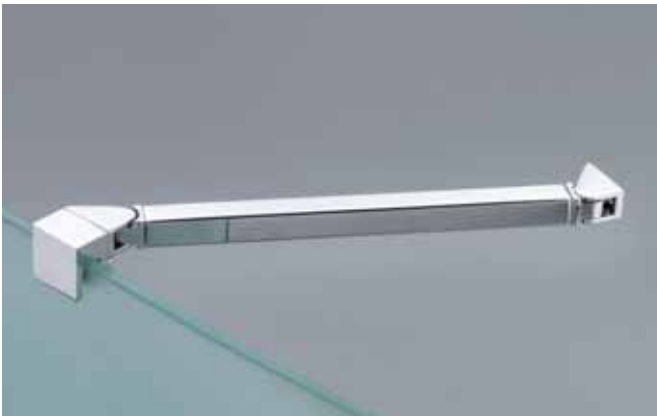

B-511-220 / B-511-370

- Barra di supporto quadra angolare snodata vetro/muro.
 - Square support bar wall/glass.
 - Eckige Stabilisationsstange Wand/Glas.
- CR - NS

e► B.289

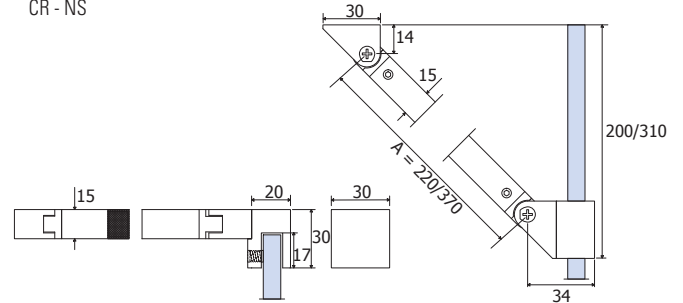

B-521

- Barra di supporto quadra a 90° vetro/muro.
 - Square support bar wall/glass 90°.
 - Eckige Stabilisationsstange Wand/Glas 90°.
- CR - NS

e► B.291

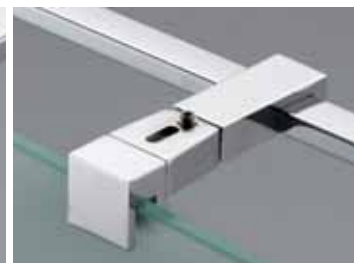
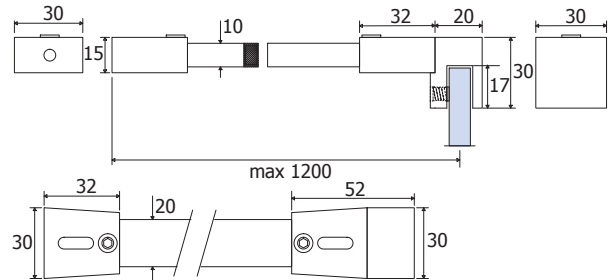

B-529 e► B.292

- Barra centrale quadra per B-527, B-528 L=1200 mm.
 - Square support bar for B-527, B-528 L=1200 mm.
 - Eckige Stabilisationsstange für B-527, B-528 L=1200 mm.
- CR - NS

B-528 e► B.293

- Attacco a muro per barra di supporto quadra B-529.
 - Wall fitting for B-529 support bar.
 - B-529 Stabilisationsstange Wandanschluss.
- CR - NS

B-527 e► B.294

- Attacco a vetro per la barra quadra B-529.
 - Glass fitting for support bar B-529.
 - Glasanschluss für Stabilisationsstange B-529 zu können.
- CR - NS

B-523 e► B.295

- Supporto centrale per vetro fisso laterale con barra B-521 / B-529.
 - Middle connector glass fitting/Square bar support B-521 / B-529.
 - Mittelverbinder Glasanschluss/Square Stabilisationsstange B-521 / B-529.
- CR - NS

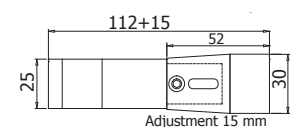
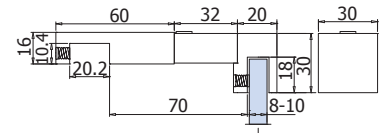
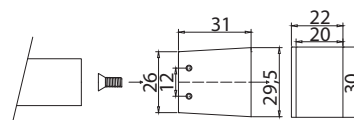
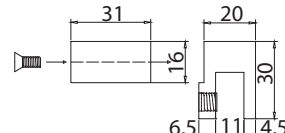
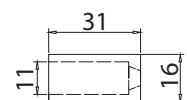
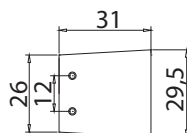
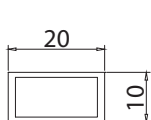

SEPARÉ

xme397

xme396

xme203

CR
Cromo lucido
Polished chrome
Chrom glänzend
154

NS
Nickel satinato
Satin nickel
Ähnlich Edelstahl matt

BARRE DI SUPPORTO TONDE

ROUND SUPPORT BARS / RUNDE STABILISATIONSSTANGEN



B-189

- Barra di fissaggio vetro/soffitto.
 - Glass to ceiling fixing bar.
 - Stabilisationsstange Glas-Decke.
- CR

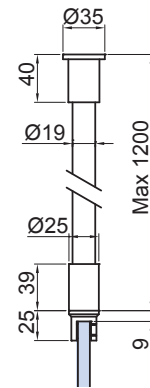
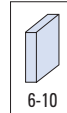

e▶ B.313

xfb-086



B-185-S

- Attacco verticale a vetro per tubo Ø 19.
 - Vertical glass clamp for Ø 19 mm tube.
 - Vertikal Rohrverbinder / Glas für Rohr Ø 19 mm.
- CR

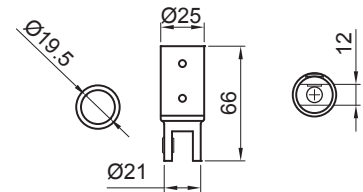

e▶ B.312

xfb-089



SEPARÉ

BARRE DI SUPPORTO TONDE

ROUND SUPPORT BARS / RUNDE STABILISATIONSTANGEN



B-171 [e► B.299](#)

- Barra di fissaggio vetro/muro.
- Glass to wall fixing bar.
- Stabilisationsstange Glas/Wand.

CR - NS

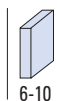
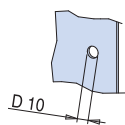
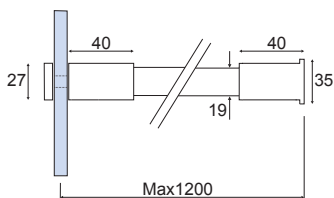

B-160 [e► B.296](#)

- Barra di fissaggio vetro/muro 45°.
- Glass to wall 45° fixing bar.
- Stabilisationsstange Glas-Wand 45°.

CR - NS

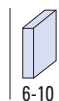
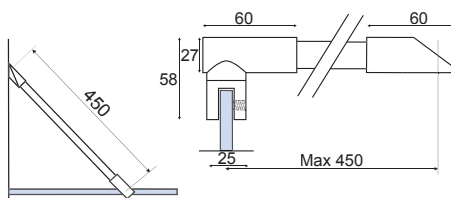

B-174 [e► B.302](#)

- Terminale a muro per barre fermavetro Ø 19 mm.
- Wall fixing bar end for Ø 19 mm tube.
- Drehbar Halterungen für Stabilisationsstange.

CR - NS

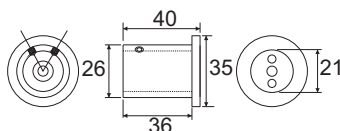

B-185 [e► B.303](#)

- Attacco a vetro per tubo Ø 19 mm.
- Ottone forgiato.
- Glass clamp for 19 mm tube. Forged brass.
- Rohrverbinder / Glas für Rohr Ø 19 mm.
- Messing geschmiedet.

CR - NS

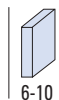
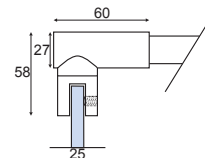

B-175 (L=1200 mm) [e► B.300](#)
B-176 (L=2000 mm) [e► B.301](#)

- Tubo inox lucido Ø 19 mm.
- Polished stainless steel tube Ø 19 mm.
- Halterungen für Stabilisationsstange.

CR - NS

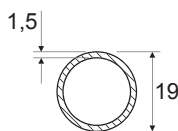

B-181 [e► B.311](#)

- Raccordo vetro-barra a 90°.
- Connector Glass-bar 90°.
- Verbinder Glas/Rohr 90°.

CR - NS

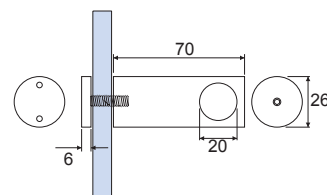

B-172 [e► B.304](#)

- Raccordo di congiunzione a 90° per tubo Ø 19 mm.
- Forged brass 90° connection joint for 19 mm tube.
- Stabilisationsstange T-Stück für 19 mm Rohr.

CR - NS

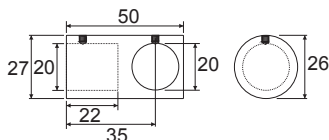

B-163 [e► B.307](#)

- Attacco a vetro foro passante per tubo Ø 19 mm.
- Glass clamp for 19 mm tube.
- Rohrverbinder/Glas für Rohr Ø 19 mm.

CR - NS

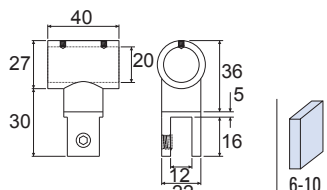

SEPARÉ



- B-161** [e▶ B.297](#)
- Barra di fissaggio vetro/muro 90°.
 - Glass to wall 90° fixing bar.
 - Stabilisationsstange Glas-Wand.

CR - NS

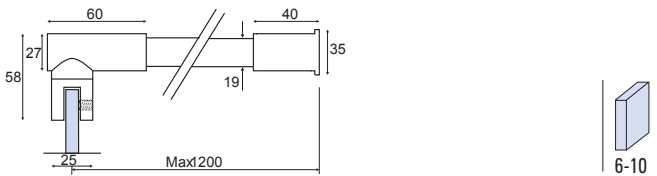

- B-162** [e▶ B.298](#)
- Barra di fissaggio vetro/vetro.
 - Glass to glass fixing bar.
 - Stabilisationsstange Glas-Glas.

CR - NS

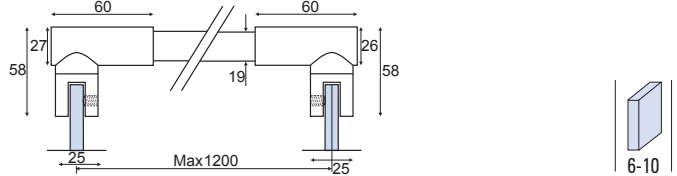

- B-167** [e▶ B.306](#)
- Fermavetro snodata a muro.
 - Ends Forged brass.
 - Halterungen für Stabilisationsstange.
- CR - NS

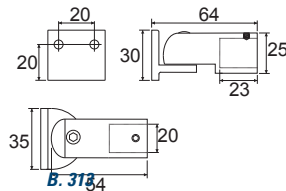

- B-166** [e▶ B.305](#)
- Terminali per barra.
 - Articulated glass to wall bar.
 - Drehbar Messing geschmiedet.
- CR - NS

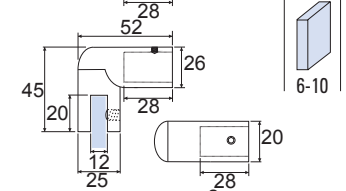

- B-164** [e▶ B.308](#)
- Raccordo a 135° per tubo Ø19 mm.
 - 135° connector for 19 mm tube Forged brass.
 - Rohrverbinder 135° für Rohr Ø 19 mm.
- CR - NS

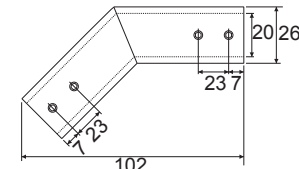

- B-165** [e▶ B.309](#)
- Raccordo a 90° per tubo Ø19 mm.
 - 90° connector for 19 mm tube.
 - Rohrverbinder 90° für Rohr Ø 19 mm.
- CR - NS

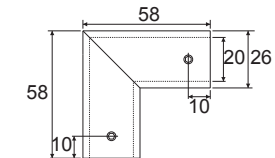

- B-184** [e▶ B.309.1](#)
- Terminale a muro 45° per barre fermavetro Ø 19 mm.
 - Wall fixing bar 45° end for Ø 19 mm tube.
 - Drehbar Halterungen 45° für Stabilisationsstange.
- CR - NS

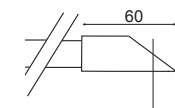

- B-173** [e▶ B.310](#)
- Raccordo regolabile per tubo Ø 19 mm.
 - Adjustable connector for Ø 19 mm tube.
 - Verbinder für 19 mm Rohr Verstellbar.
- CR - NS

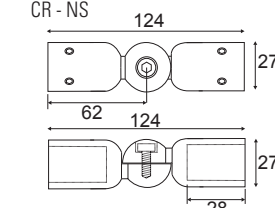

CR
Cromo lucido
Polished chrome
Chrom glänzend

NS
Nickel satinato
Satin nickel
Ähnlich Edelstahl matt

SEPARÉ

ACCESSORI

ACCESSORIES / ZUBEHÖRE

- MORSETTI
- CLAMPS
- KLEMMBESCHLÄGE



**B-155/40 / B-154/40 / B-156/40 / B-152/40 / B-153/40
B-157/40 / B-158/40 / B-182 / B-183 / B-187 / B-188
B-159-50 / B-160-50 / B-110 / B-111**

► 160

- RAGNETTI
- CONNECTORS
- WINKELVERBINDER



B-20 / B-25 / B-21 / B-30 / B-35 / B-16 / B-17

► 164

- GUARNIZIONI MINI
- MINI GASKETS
- MINI DICHTUNGEN

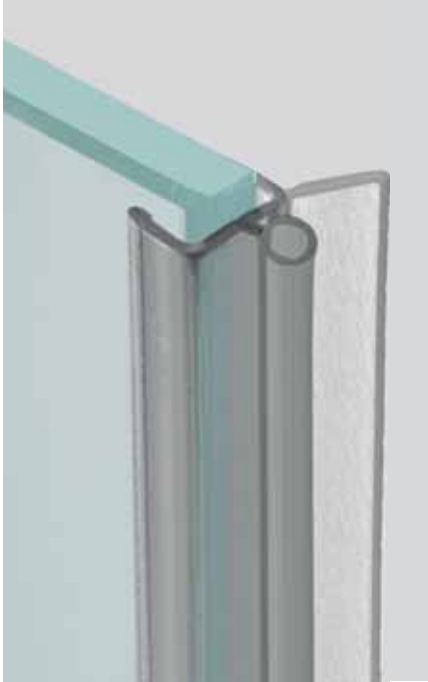

**B-115-20 / B-115-25 / B-142-8
 B-144-8 / B-116-8 / B-117-8
 B-118-8 / B-119-8**

► 166

- GUARNIZIONI
- GASKETS
- DICHTUNGEN



**B-151-26 / B-151-20 / B-141-8
 B-141-10 / B-143-8 / B-143-10
 B-145-8 / B-145-10 / B-147-8
 B-147-10 / B-149-8 / B-149-10
 B-152-8 / B-153-8 / B-154-8 / B-155-8
 WRU-S 60/40 R / WRU-M 80/50**

► 168

- POMOLI, NICCHIE, MANIGLIONI
- KNOBS, SLIDING HANDLES, HANDLES
- KNÖPFE, GRIFFMUSCHEL, STOSSGRIFFE



**V-024 25 / V-024 30 / V-024 38
 V-1107 / B-197 / B-168 / B-169
 B-177 / B-178 / B-192 / B-194
 B-195 / V-019 / V-1056 / V-1056-2
 V-1105 / B-186 / B-170 / V-526
 V-528 / B-179 / B-180 / B-193**

**SQUARE 10 / POR-0408 V / POR-0400 V
 B-191-80 / B-191-20
 SQUARE MINI / ROUND MINI
 SQUARE ALU / ZAMA
 SQAURE 10 / B-120 / B-121 / B-122
 B-124 / B-125**

PG-CHIAVE

► 172

MORSETTI CLAMPS / KLEMMBESCHLÄGE



B-155-40

- Morsetto 40x40 mm vetro/muro. Materiale: Ottone.
- Glass to wall clamp 40x40 mm. Material: Brass.
- Verbinder Glas-Wand, 40x40 mm mit nicht sichtbaren Schrauben. Material: Messing.

CR - NS

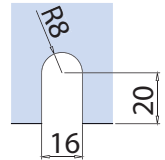
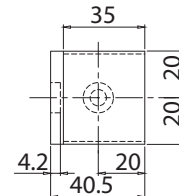
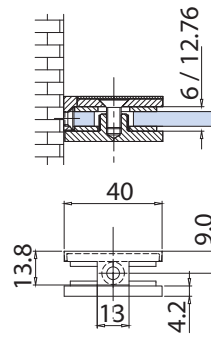

e► B.350

xme312



B-154-40

- Morsetto 40x40 mm vetro/muro. Materiale: Ottone.
- Glass to wall clamp 40x40 mm. Material: Brass.
- Verbinder Glas-Wand, 40x40 mm mit nicht sichtbaren Schrauben. Material: Messing.

CR - NS

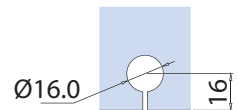
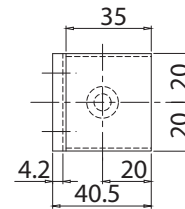
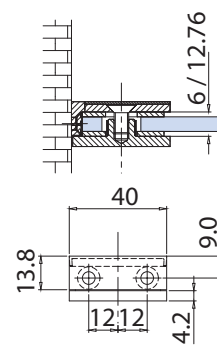

e► B.348

xme312



B-156-40

- Morsetto angolare 90° 40x40 mm vetro/muro. Materiale: Ottone.
- Glass to wall angular clamp 90° 40x40 mm. Material: Brass.
- Winkelverbinder Glas-Wand 90°, 40x40 mm mit nicht sichtbaren Schrauben. Material: Messing.

CR - NS

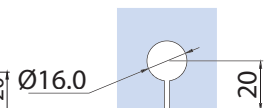
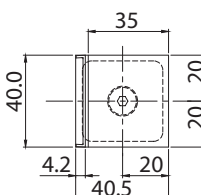
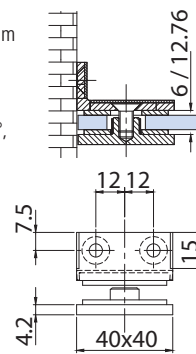

e► B.350

xme313



B-152-40

- Morsetto angolare 40x40 mm vetro/muro 90°. Materiale: Ottone.
- Glass to wall 90° angular clamp 40x40 mm. Material: Brass.
- Winkelverbinder Glas-Wand 90°, 40x40 mm mit nicht sichtbaren Schrauben. Material: Messing.

CR - NS

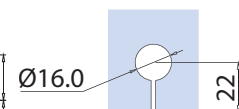
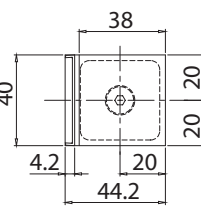
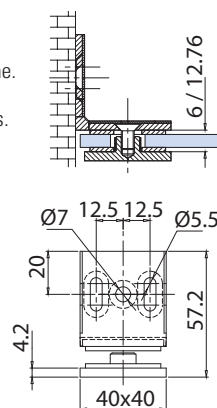

e► B.346

xme312

B-153-40

- Morsetto angolare 40x40 mm vetro/vetro 90°. Materiale: Ottone.
- Glass to glass 90° angular clamp 40x40 mm. Material: Brass.
- Winkelverbinder Glas-Glas 90°, 40x40 mm mit nicht sichtbaren Schrauben. Material: Messing.

CR - NS

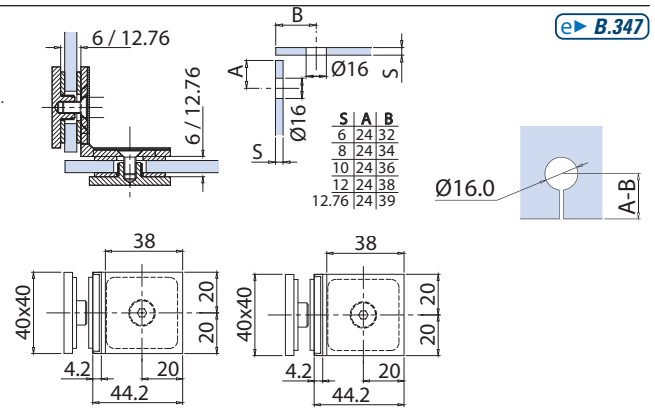

e► B.347

xme312

B-157-40

- Morsetto 40x40 mm vetro/muro 180°. Materiale: Ottone.
- Glass to wall clamp 180° 40x40 mm. Material: Brass.
- Verbinder Glas-Wand 180°, 40x40 mm mit nicht sichtbaren Schrauben. Material: Messing.

CR - NS

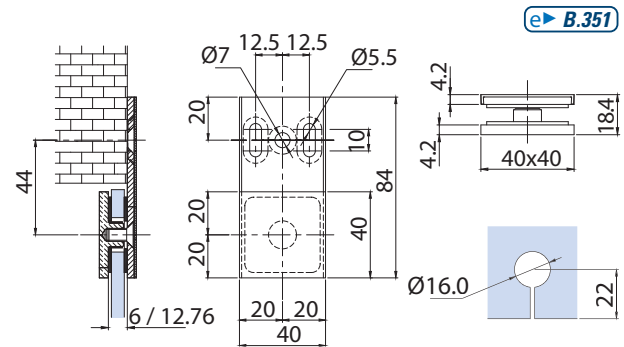

e► B.351

xme313

B-158-40

- Morsetto 40x40 mm vetro/vetro 180°. Materiale: Ottone.
- Glass to glass clamp 180°, 40x40 mm. Material: Brass.
- Verbinder Glas-Glas 180°, 40x40 mm mit nicht sichtbaren Schrauben. Material: Messing.

CR - NS

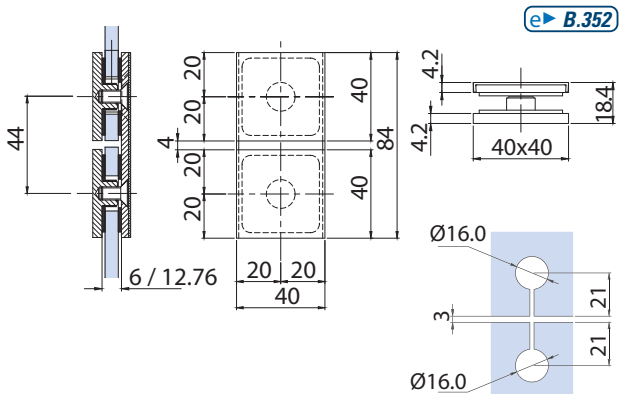

e► B.352

xme313

B-182

- Morsetto angolare 56x40 mm vetro/muro 90°. Materiale: Ottone.
- Glass to wall 90° angular clamp 56x40 mm. Material: Brass.
- Winkelverbinder Glas-Wand 90°, 56x40 mm mit nicht sichtbaren Schrauben. Material: Messing.

CR - NS

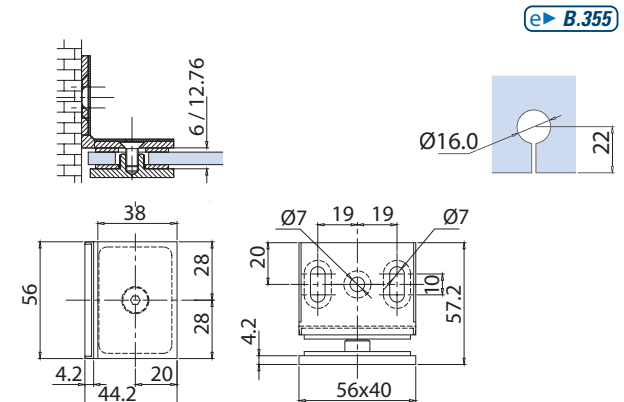

e► B.355

xme314

CR Cromo lucido Polished chrome Chrom glänzend	NS Nickel satinato Satin nickel Ähnlich Edelstahl matt
--	--



B-183

- Morsetto angolare 56x40 mm vetro/vetro 90°. Materiale: Ottone.
- Glass to glass 90° angular clamp 56x40 mm. Material: Brass.
- Winkelverbinder Glas-Glas 90°, 56x40 mm mit nicht sichtbaren Schrauben. Material: Messing. CR - NS

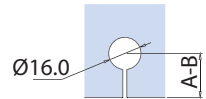
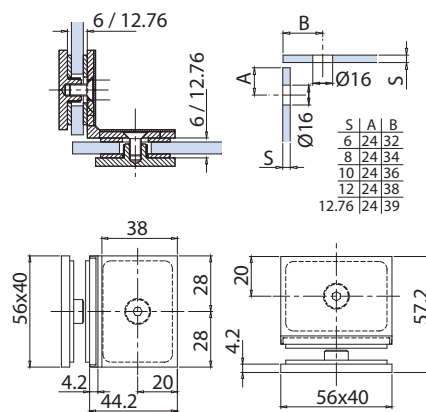

xme314

B-187



B-187

- Morsetto 56x40 mm vetro/muro 180°. Materiale: Ottone.
- Glass to wall clamp 180°, 56x40 mm. Material: Brass.
- Verbinder Glas-Wand 180°, 56x40 mm mit nicht sichtbaren Schrauben. Material: Messing. CR - NS

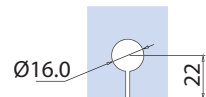
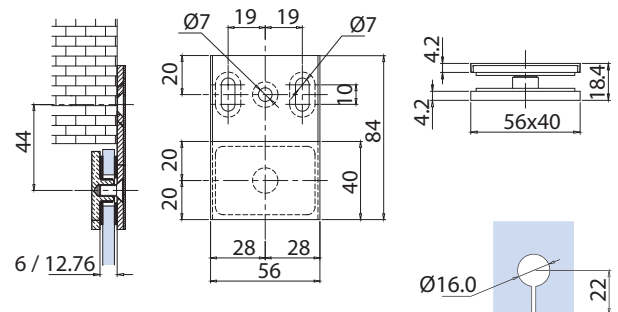

xme314

B-188



B-188

- Morsetto 56x40 mm vetro/vetro 180°. Materiale: Ottone.
- Glass to glass clamp 180°, 56x40 mm. Material: Brass.
- Verbinder Glas-Glas 180°, 56x40 mm mit nicht sichtbaren Schrauben. Material: Messing. CR - NS

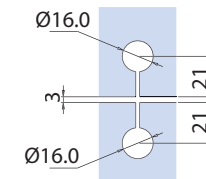
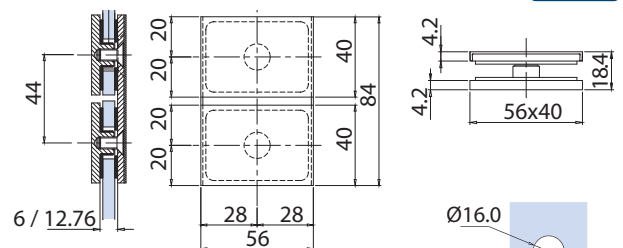

xme314

B-159-50



B-159-50

- Morsetto angolare 50x50 mm vetro/muro senza viti in vista.
- Glass to wall 90° angular clamp 50x50 mm with not visible screws.
- Winkelverbinder Glas-Wand 90° 50x50 mm mit nicht sichtbaren Schrauben. CR

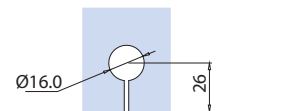
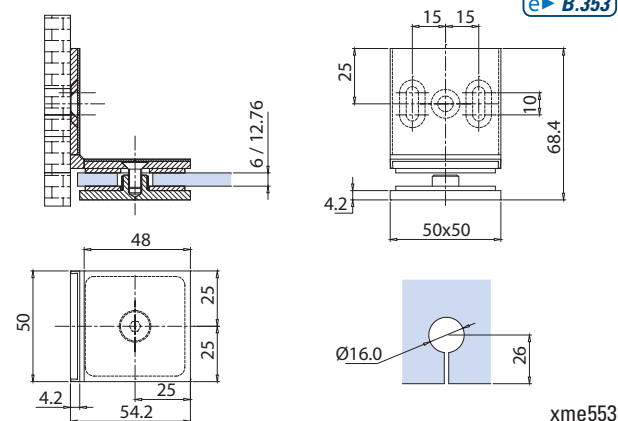
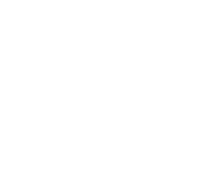

xme553

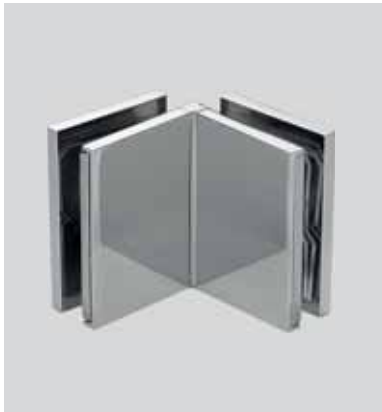
B-160-50

- Morsetto angolare 50x50 mm vetro/vetro 90°. Senza viti a vista.
- Glass to glass 90° angular clamp 50x50 mm. With not visible screws.
- Winkelverbinder Glas-Glas 90°, 50x50 mm mit nicht sichtbaren Schrauben. Ohne sichtbare Schrauben.

CR - NS

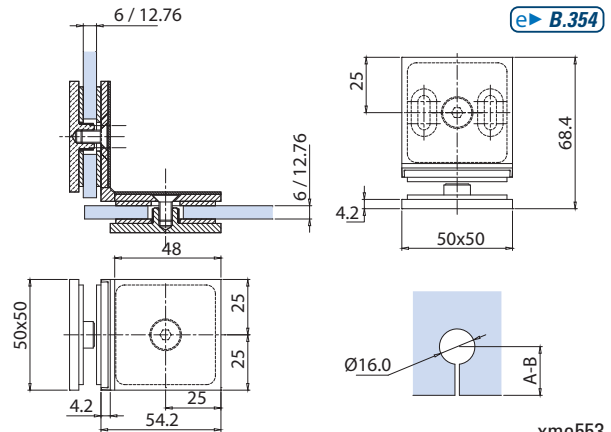
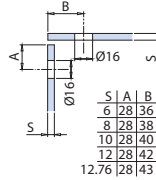

e▶ B.354

xme553

B-110

- Morsetto vetro/muro a filo. Materiale: Ottone.
- Glass to wall clamp. Material: Brass.
- Verbinder Glas-Wand. Material: Messing.

CR - NS

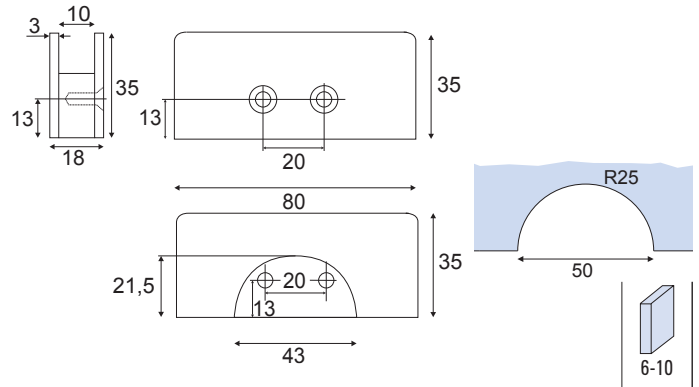

e▶ B.359

B-111

- Morsetto angolare vetro/muro 90°. Materiale: Ottone.
- Glass to wall 90° angular clamp. Material: Brass.
- Winkelverbinder Glas-Wand 90°. Material: Messing.

CR - NS

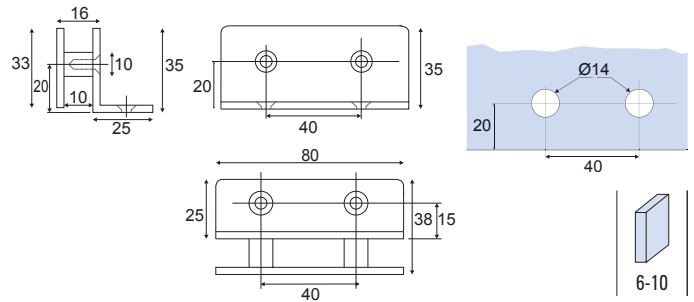

e▶ B.360

RAGNETTI

CONNECTOR / WINKELVERBINDER



B-20

- Ragnetto muro/vetro.
Materiale: Inox.
- Connector glass/wall.
Material: Stainless.
- Winkelverbinder Glas/Wand.
Material: Edelstahl.
IX - IL

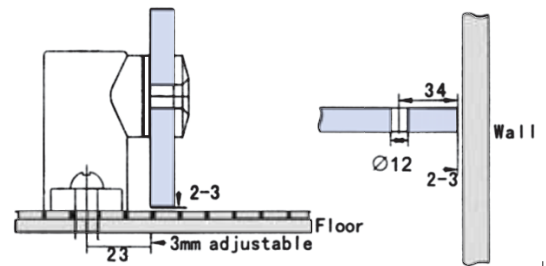

e▶ B.363

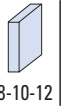

B-25

- Barra di connessione 2 vetri.
Materiale: Inox.
- Connecting rod for 2 glass.
Material: Stainless.
- Verbinder 2 Gläser.
Material: Edelstahl.
IX - IL

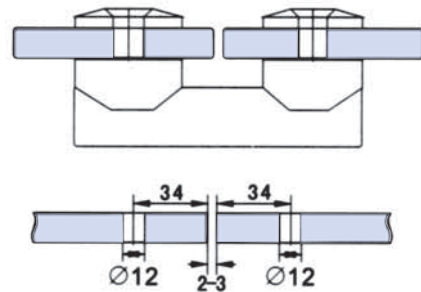

e▶ B.365

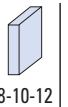

B-21

- Ragnetto vetro/vetro.
Materiale: Inox.
- Connector glass/glass.
Material: Stainless.
- Winkelverbinder Glas/Glas.
Material: Edelstahl.
IX - IL

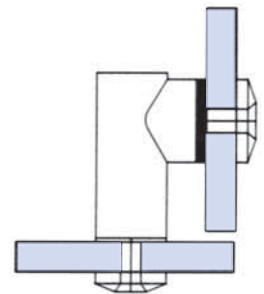

e▶ B.364

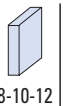

B-30

- Ragnetto muro/vetro.
Materiale: Inox.
- Connector glass/wall.
Material: Stainless.
- Winkelverbinder Glas/Wand.
Material: Edelstahl.
IX - IL

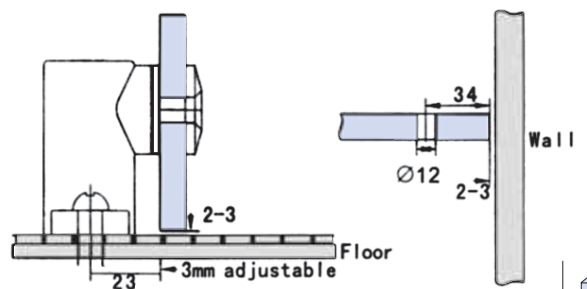

e▶ B.366

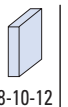

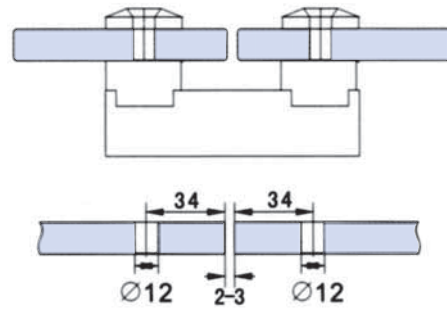

B-35

- Barra di connessione 2 vetri.
Materiale: Inox.
 - Connecting rod for 2 glass.
Material: Stainless.
 - Verbinder 2 Gläser.
Material: Edelstahl.
- IX - IL

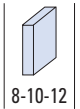

e▶ B.367

B-16

- Fermaporta con attacco a terra e calamita.
Materiale: Inox.
 - Magnetic door hold and stopper wall/glass.
Material: Stainless.
 - Magnetische Türstopper Wand/Glas.
Material: Edelstahl.
- IX - IL

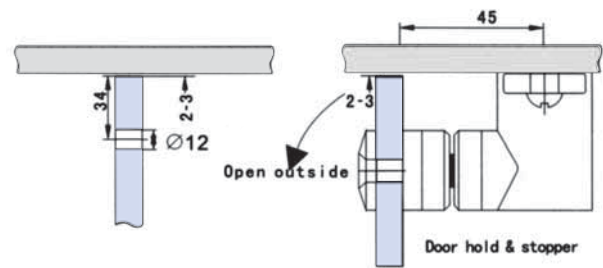

e▶ B.361

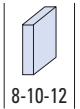
B-17

- Fermaporta con attacco a vetro e calamita.
Materiale: Inox.
 - Magnetic door hold and stopper glass/glass.
Material: Stainless.
 - Magnetische Türstopper Glas/Glas.
Material: Edelstahl.
- IX - IL

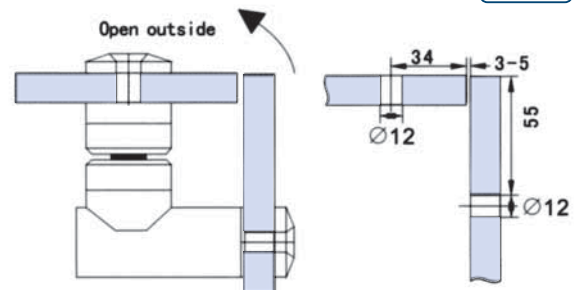

e▶ B.362

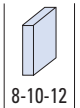

GUARNIZIONI MINI MINI GASKETS / MINI DICHTUNGEN

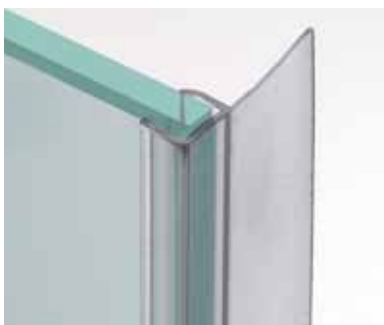
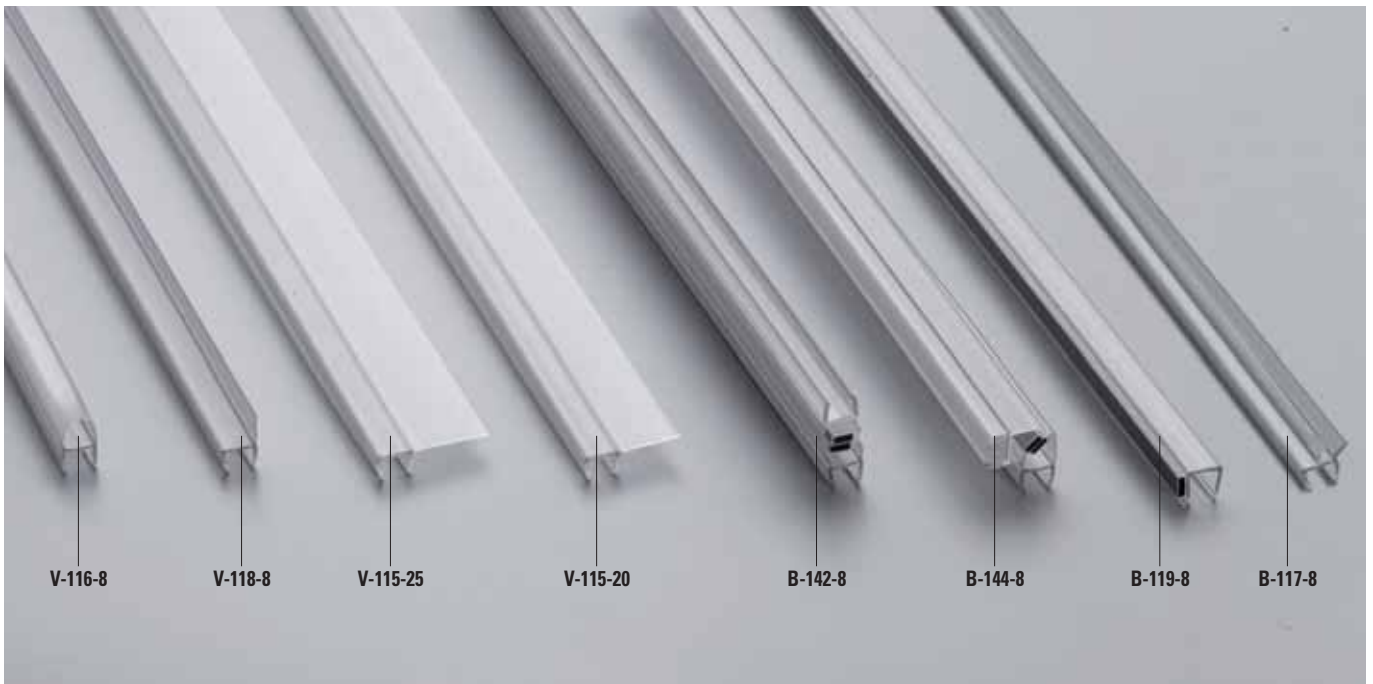

B-115-20

- Guarnizione per scorrevoli in PVC trasparente.
- Sliding doors seal in transparent PVC.
- PVC Dichtprofil für Schiebetüren.

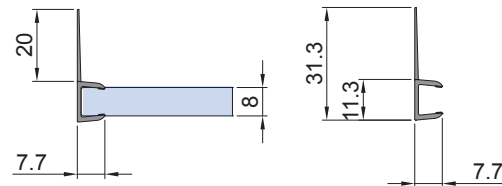

e▶ B.371

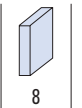

xfb-095



B-115-25

- Guarnizione per scorrevoli in PVC trasparente.
- Sliding doors seal in transparent PVC.
- PVC Dichtprofil für Schiebetüren.

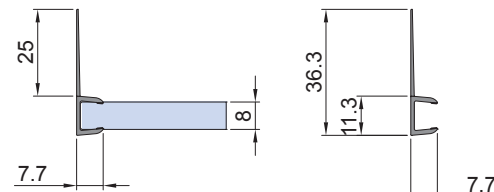

e▶ B.370

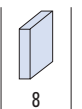

xfb-095



B-142-8

- Guarnizione magnetica in PVC trasparente per chiusura a 180°.
- PVC magnetic seal for 180° closing doors in transparent PVC twin bars.
- PVC Magnetdichtung für Glas-Glas 180° Paar Profile.

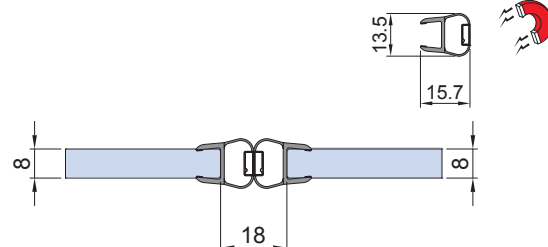

e▶ B.372

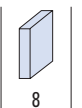

xfb-093

B-144-8

- Guarnizione magnetica in PVC trasparente per chiusure a 90°.
- PVC magnetic seal for 90° closing doors in transparent PVC
- Magnetdichtung für Glas-Glas 90°.

L=2500

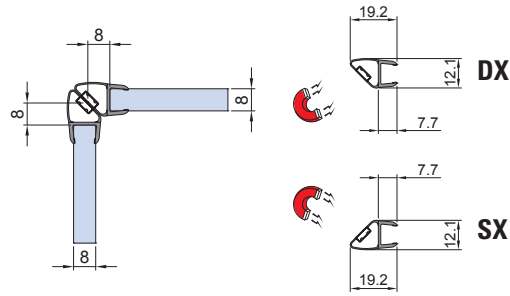
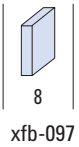
B.373

B-116-8

- Guarnizione a palloncino vetro/muro in PVC trasparente.
- Glass to wall ball seal transparent PVC.
- PVC Dichtprofil Glas-Wand.

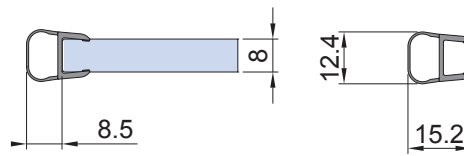
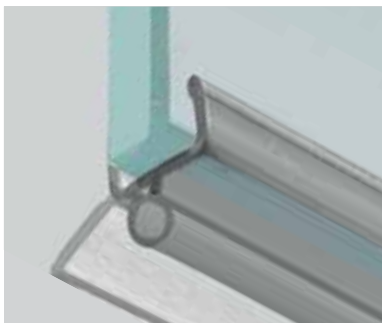
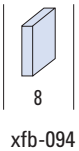
L=2500

B.368

B-117-8

- Guarnizione gocciolatoio in PVC trasparente.
- Drip flap seal transparent PVC.
- PVC Dichtprofil für den unteren Wannenanschluss.

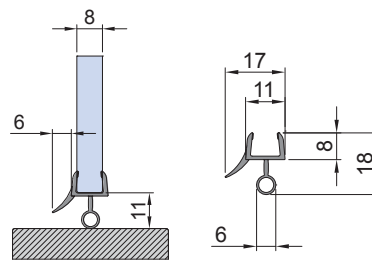
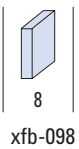
L=2500

B.375

B-118-8

- Guarnizione vetro/vetro in PVC trasparente per chiusure a 180°.
- Door stop seal transparent PVC for glass-glass 180°.
- PVC Dichtprofil für Glas-Glas 180°.

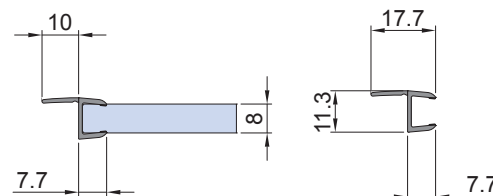
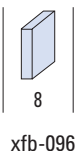
L=2500

B.369

B-119-8

- Guarnizione bordo vetro con magneti, per chiusura a battuta.
- Closure gasket with magnetic seal.
- Vertikal Dichtung für Magnetische Zuhaltung.

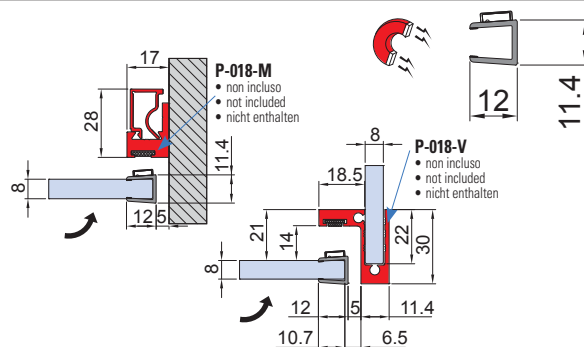
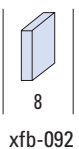
L=2500

B.374

GUARNIZIONI GASKETS / DICHTUNGEN

- Alcune tipologie di applicazione
- Some application typologies
- Einigen kompositionsmöglichkeiten des system

- Doccia a battente ad angolo con vetro fisso.
- Angled shower cabin with swing door and fixed panel.
- Eck-Duschkabin mit Drehtür und Seitenteil.

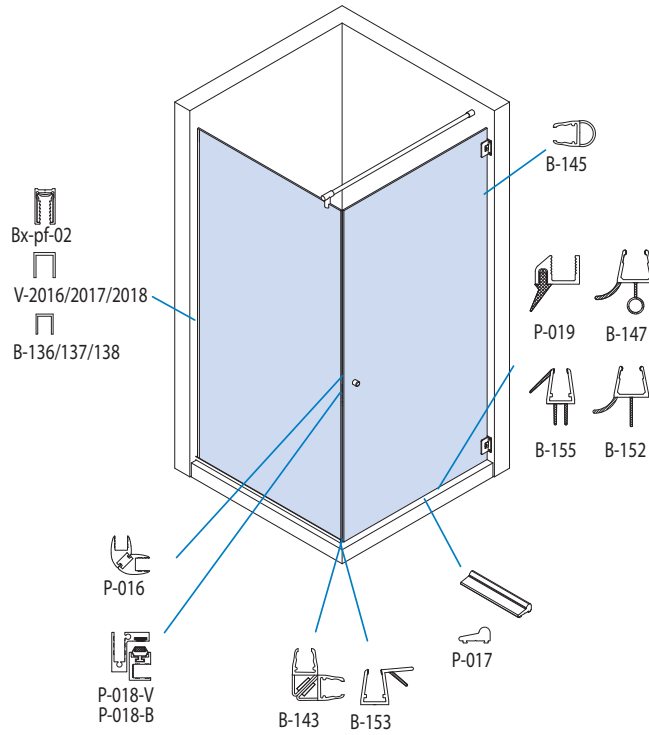

- Doccia scorrevole con vetri fissi laterali.
- Shower cabin with sliding door and fixed side panels.
- Duschkabin mit Schiebetür und Seitenteilen.

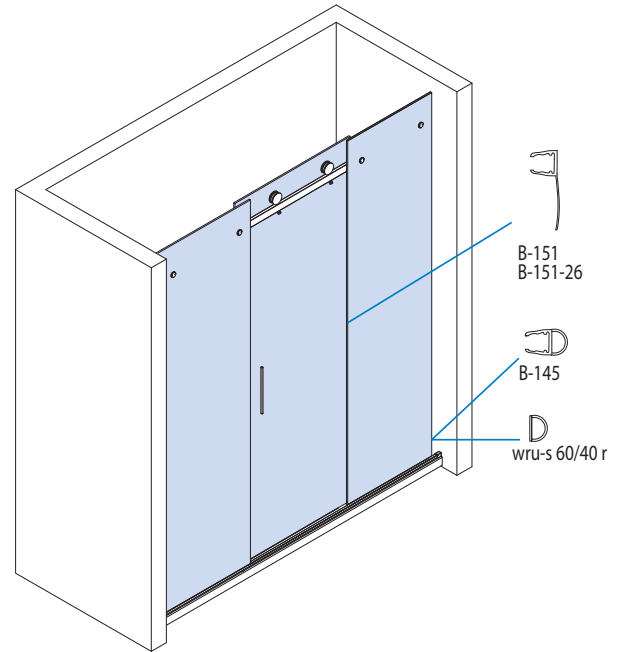

- Doccia a battente con vetri fissi laterali.
- Shower cabin with swing door and fixed side panels.
- Duschkabin mit Drehtür und Seitenteilen.

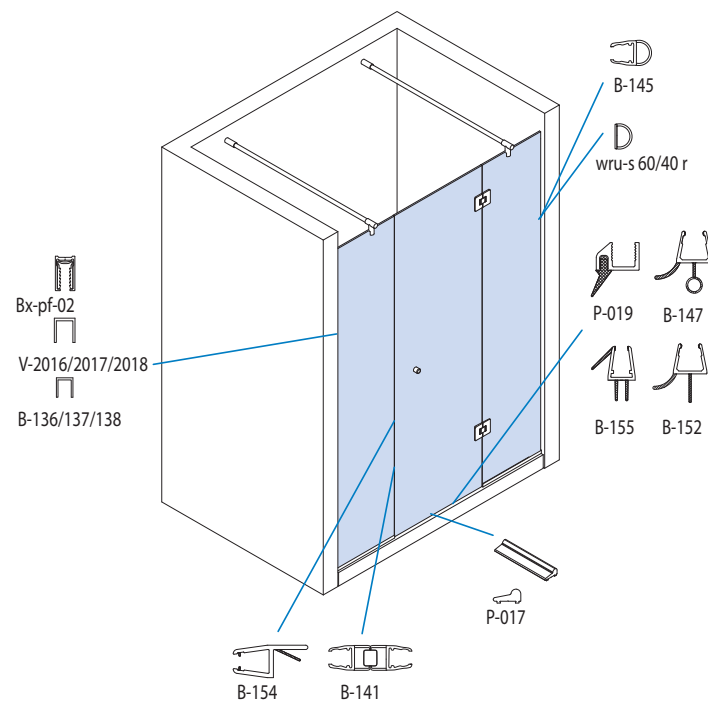

- Doccia a battente.
- Shower cabin with swing door.
- Duschkabin mit Drehtür.

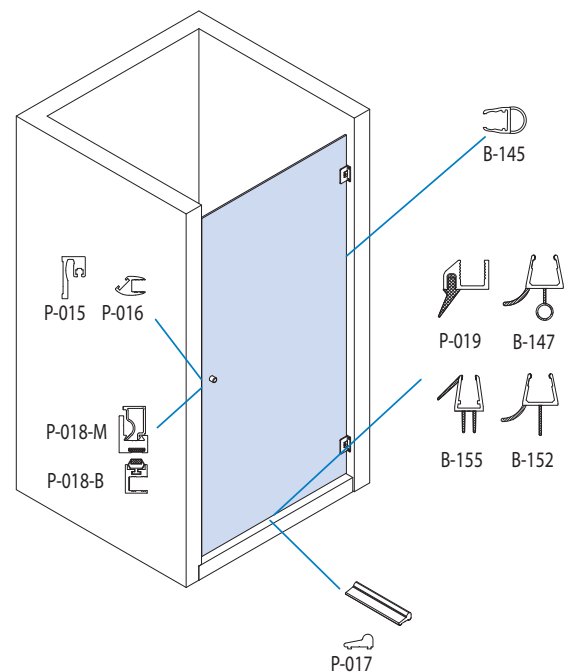

xme318

B-151-26

- Guarnizione per scorrevoli in PVC trasparente.
- Sliding doors seal transparent PVC.
- PVC Dichtprofil für Schiebetüren.

1 pcs L=2200

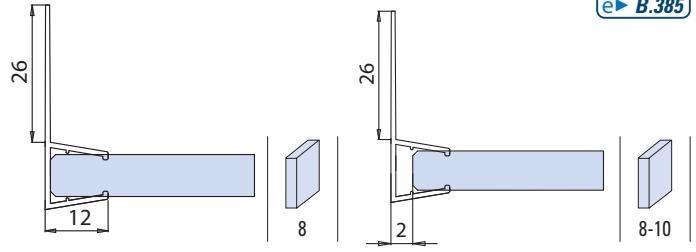

[e▶ B.385](#)

xme390-B

B-151-20

- Guarnizione per scorrevoli in PVC trasparente.
- Sliding doors seal transparent PVC.
- PVC Dichtprofil für Schiebetüren.

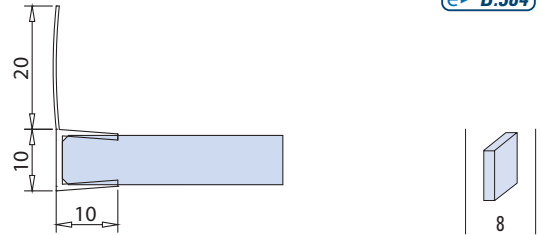
1 pcs L=2200



[e▶ B.384](#)

xme390-C

B-141-8

- Guarnizione magnetica.
- Pvc magnetic seal.
- Pvc Magnetdichtung für Glas-Glas.

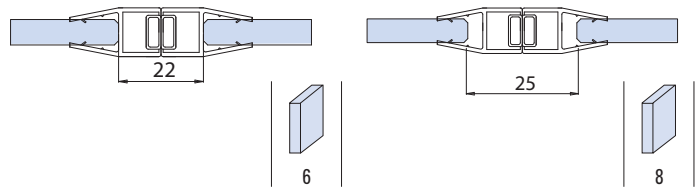
1 pcs L=2200



[e▶ B.376](#)

xme390-B

B-141-10

- Guarnizione magnetica.
- Pvc magnetic seal.
- Pvc Magnetdichtung für Glas-Glas.

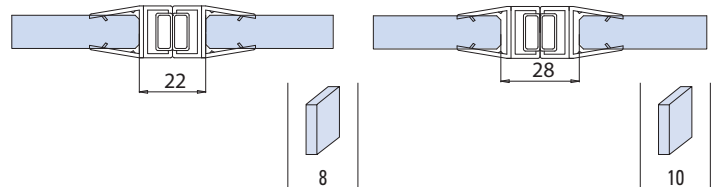
1 pcs L=2500



[e▶ B.377](#)

xme390-B

B-143-8

- Guarnizione magnetica in PVC trasparente.
- PVC magnetic seal transparent PVC.
- PVC Magnetdichtung für Glas-Glas 90°.

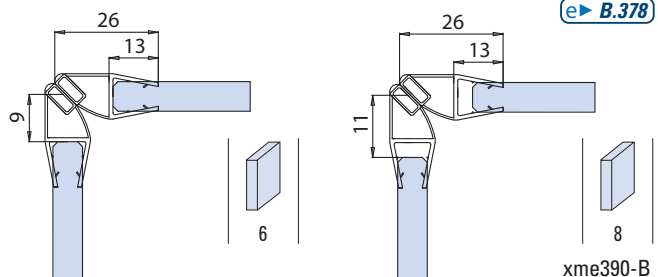
1 pcs L=2500



[e▶ B.378](#)

xme390-B

B-143-10

- Guarnizione magnetica in PVC trasparente.
- PVC magnetic seal transparent PVC.
- PVC Magnetdichtung für Glas-Glas 90°.

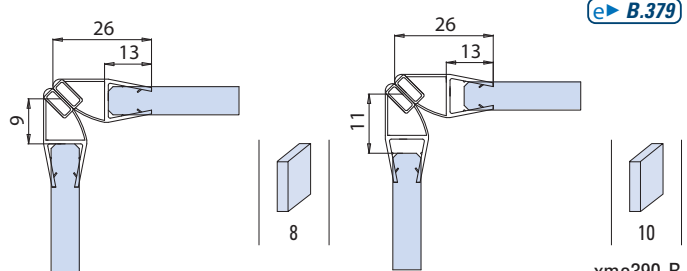
1 pcs L=2500

[e▶ B.379](#)

xme390-B





B-145-8

- Guarnizione a palloncino vetro/muro in PVC trasparente.
- Glass to wall ball seal transparent PVC.
- PVC Dichtprofil Glas-Wand.

1 pcs L=2500

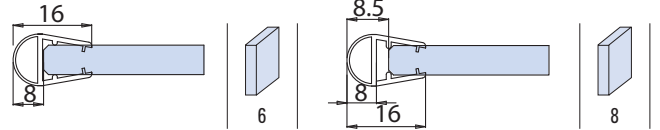

e► **B.380**

xme390-A



B-145-10

- Guarnizione a palloncino vetro/muro in PVC trasparente.
- Glass to wall ball seal transparent PVC.
- PVC Dichtprofil Glas-Wand.

1 pcs L=2500

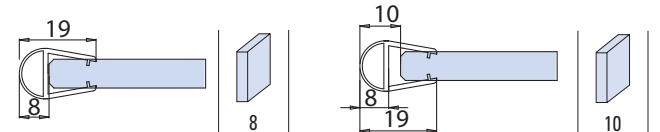

e► **B.381**

xme390-A



B-147-8

- Guarnizione gocciolatoio in PVC trasparente.
- Drip flap seal transparent PVC.
- PVC Dichtprofil für den unteren Wannenanschluss.

1 pcs L=2200

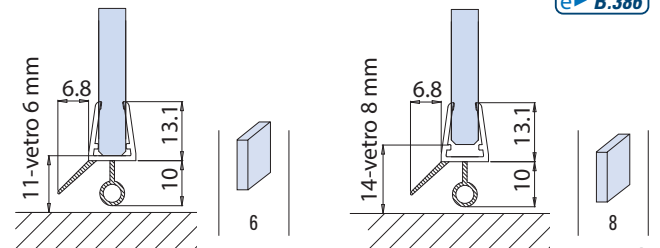

e► **B.386**

xme390-A



B-147-10

- Guarnizione gocciolatoio in PVC trasparente.
- Drip flap seal transparent PVC.
- PVC Dichtprofil für den unteren Wannenanschluss.

1 pcs L=2200

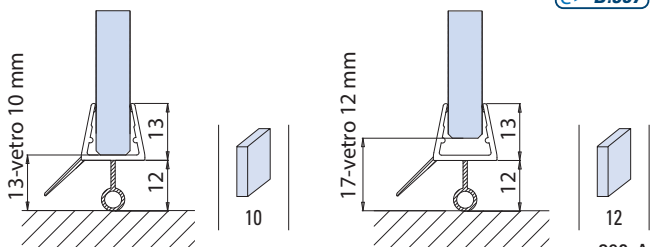

e► **B.387**

xme390-A



B-149-8

- Guarnizione vetro/vetro in PVC trasparente.
- Door stop seal transparent PVC.
- PVC Dichtprofil für Glas-Glas 180°.

1 pcs L=2500

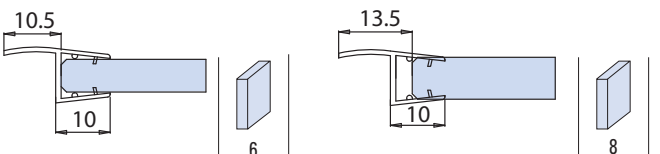

e► **B.382**

xme390-B



B-149-10

- Guarnizione vetro/vetro in PVC trasparente.
- Door stop seal transparent PVC.
- PVC Dichtprofil für Glas-Glas 180°.

1 pcs L=2500

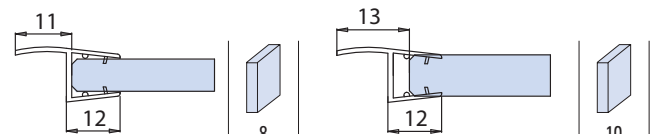

e► **B.383**

xme390-B

B-152-MIX

- Guarnizione gocciolatoio in PVC trasparente.
- Drip flap seal in transparent PVC.
- PVC Dichtprofil für den unteren Wannenanschluss, für 8 und 10 mm Glas.

1 pcs L=2200

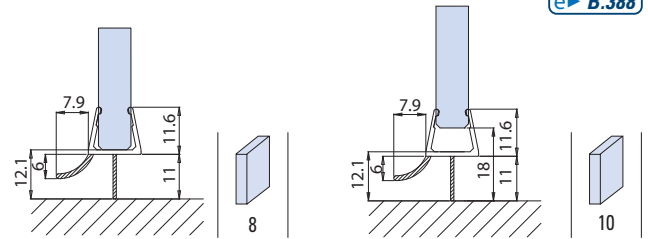

[e▶ B.388](#)

xme390-B

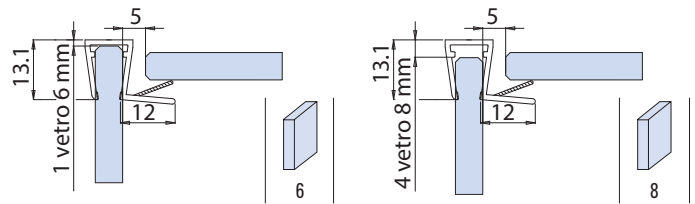

B-153-MIX

- Guarnizione a battuta in PVC trasparente.
- Seal profile glass-glass 90° with door stop in transparent PVC.
- PVC Dichtprofil glass-glass 90° mit Türanschlag, für 6 und 8 mm Glas.

1 pcs L=2200

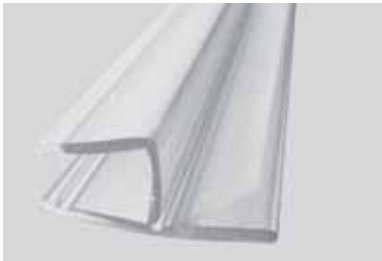

[e▶ B.389](#)

xme390-A

B-154-MIX

- Guarnizione "H" a battuta in PVC trasparente.
- Seal profile glass-glass 90° with door stop in transparent PVC.
- PVC Dichtprofil glass-glass 180° mit Türanschlag.

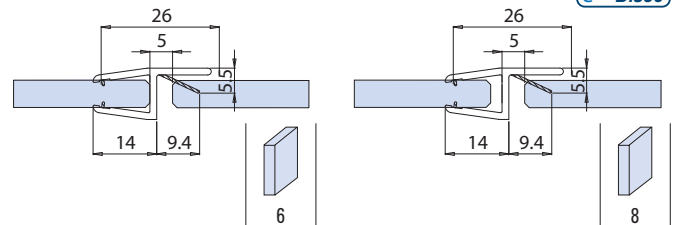
1 pcs L=2200



[e▶ B.390](#)

xme390-B

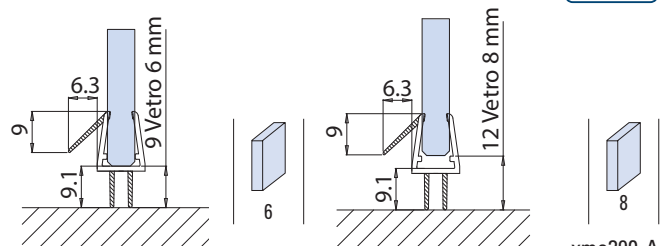

B-155-MIX

- Guarnizione con diga e deflettore in PVC trasparente.
- Drip flap seal in transparent PVC.
- PVC Dichtprofil für den unteren Wannenanschluss.

1 pcs L=2200

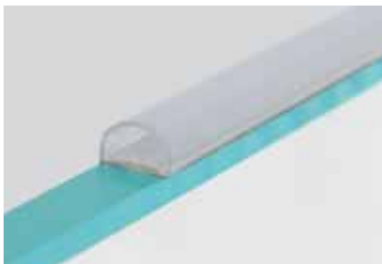

[e▶ B.391](#)

xme390-A

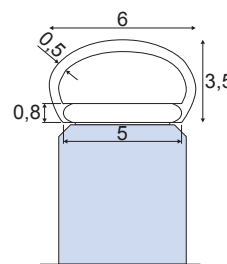

WRU-S 60/40 R

- Guarnizione neutra per vetro 8 mm. con fissaggio adesivo.
- Neutral gasket for glass 8 mm.
- Dichtungsprofil für 8 mm. Glaskante selbstklebend.

10 mtl
 50 mtl

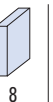

- Confezione mt. 10.
- Package unit of 10 mt.
- Verpackungseinheit von 10 lfm.

[e▶ B.393](#)

WRU-M 80/50

- Guarnizione neutra in PVC con fissaggio adesivo
- Neutral PVC gasket with adhesive fixing.
- Dichtungsprofil selbstklebend

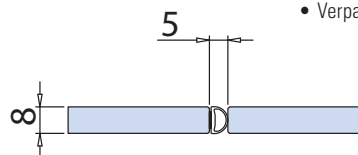
5 mtl

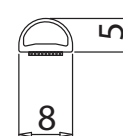
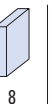

- Confezione mt. 5.
- Package unit of 5 mt.
- Verpackungseinheit von 5 lfm.

[e▶ B.392](#)

xfb-099

POMOLI, NICCHIE, MANIGLIONI KNOBS, SLIDING HANDLES, HANDLES / KNÖPFE, GRIFFMUSCHELN, STOSSGRIFFE

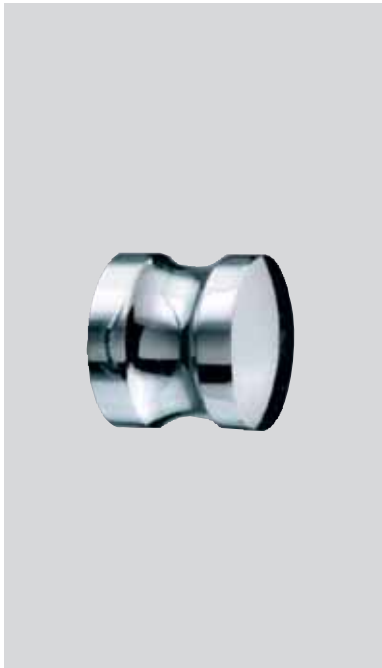

V-024 25

- Coppia pomoli Ø 25 mm.
 - Pair of doorknobs Ø 25 mm.
 - Paar Türknöpfe Ø 25 mm.
- CR - NS

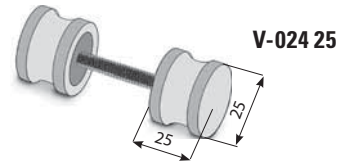

e► B.327 e► B.328
e► B.329 e► B.330

V-024 30

- Coppia pomoli Ø 30 mm.
 - Pair of doorknobs Ø 30 mm.
 - Paar Türknöpfe Ø 30 mm.
- CR - NS

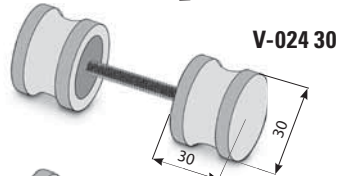

V-024 32

- Coppia pomoli Ø 32 mm.
 - Pair of doorknobs Ø 32 mm.
 - Paar Türknöpfe Ø 32 mm.
- CR - NS

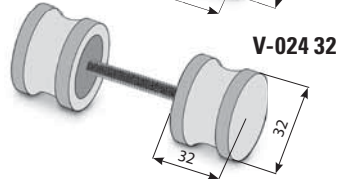

V-024 38

- Coppia pomoli Ø 38 mm.
 - Pair of doorknobs Ø 38 mm.
 - Paar Türknöpfe Ø 38 mm.
- CR - NS

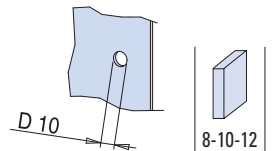
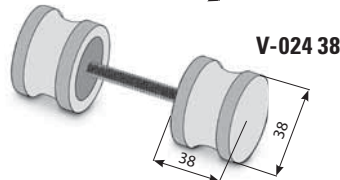

V-1107

- Coppia pomoli 35 x 35 mm foro vetro Ø 10 mm
 - Pair of doorknobs 35 x 35 mm. Hole in glass 10 mm
 - Paar Türknöpfe 35 x 35 mm. Glas Bohrung 10 mm
- CR

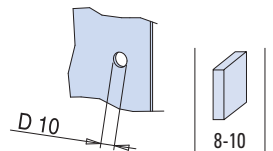

e► B.331

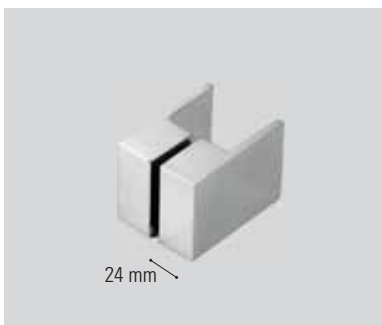

B-197

- Coppia pomoli 70 x 50 mm
 - Pair of doorknobs 70 x 50 mm
 - Paar Türknöpfe 70 x 50 mm
- CR

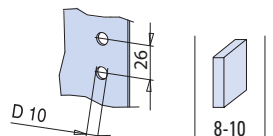

e► B.325



B-168

- Pomolo per porte in Zama.
 - Glass doors knob Zamak.
 - Paar Türknöpfe aus Zamak.
- CR - NS - CP - NO

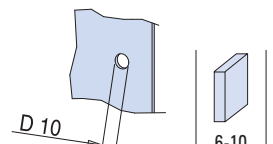
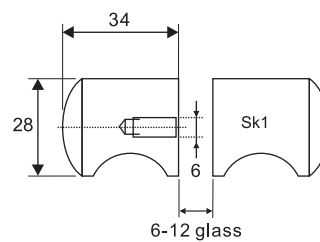

e► B.314

B-169

- Coppia pomoli 28 x 28 mm.
- Pair of doorknobs 28 x 28 mm.
- Paar Türknöpfe 28 x 28 mm.

CR

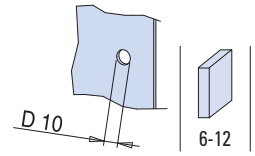
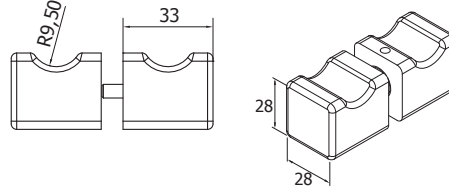
 e► **B.315**

B-177

- Paio pomolini tondi d. 15
- Pair mini knobs d. 15
- Pair mini knobs d. 15

IL - IX

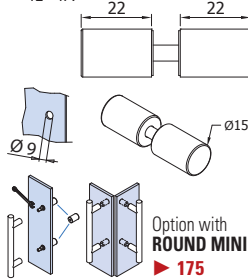
B-178

- Paio pomolini quadri q. 15
- Pair mini knobs q. 15
- Paar knöpfe mini q.15

IL - IX

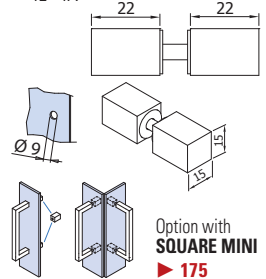
 e► **B.317**

B-192

- Pomolo ad incollaggio biadesivo.
- Knob with self-adhesive fixing.
- Knopf selbstklebend.

CR

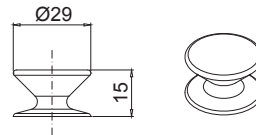
 e► **B.321**

xme311

B-194

- Coppia pomoli Ø 32 mm - Foro vetro Ø 10 mm
- Pair of doorknobs Ø 32 mm - Hole in glass 10 mm
- Paar Türknöpfe Ø 32 mm Glas Bohrung 10 mm

CR - NS

40 mm

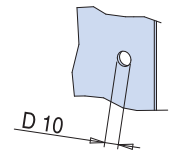

 e► **B.323**

B-195

- Coppia pomoli 25x25 mm - Foro vetro Ø 10 mm
- Pair of doorknobs 25x25 mm - Hole in glass 10 mm
- Paar Türknöpfe 25x25 mm Glas Bohrung 10 mm

CR - NS

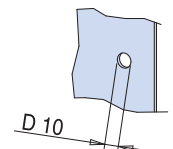
43 mm

 e► **B.324**
NS
 Nickel satinato
 Satin nickel
 Ähnlich Edelstahl matt

CR
 Cromo lucido
 Polished chrome
 Chrom glänzend

CS
 Cromo satinato
 Satin chrome
 Chrom matt

OL
 Ottone lucido
 Polished brass
 Messing poliert

CP
 Cromo perla
 Chrome perla similar Alu
 Chrom perla ähnlich Alu

AN
 Alluminio anodizzato
 Aluminium anodized
 Aluminium Silberfarbig

NO
 Nero opaco
 Matt black
 Schwarz matt



V-019

- Coppia pomoli in vetro.
 - Pair of door knobs in glass.
 - Paar Türknöpfe aus Glas.
- NS + GLASS



A = 40 / 45 / 50
S = 52 / 57 / 62

e▶ B.326

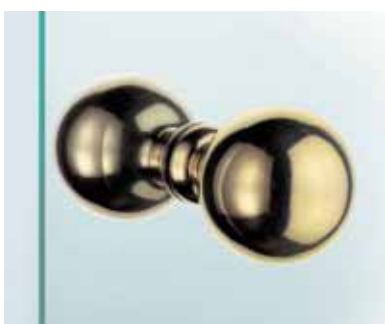
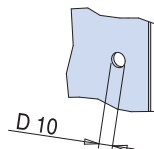

V-1056

- Coppia pomoli palla Ø 60 mm.
- Pair of door knobs Ø 60 mm.
- Paar Türknöpfe Ø 60 mm.

V-1056-2

- Coppia pomoli palla Ø 50 mm.
- Pair of door knobs Ø 50 mm.
- Paar Türknöpfe Ø 50 mm.

CS - NS - CR - OL - CP

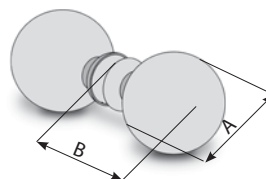

Ø 60 A = 60 / B = 78
Ø 50 A = 50 / B = 70

e▶ F.100 e▶ F.101

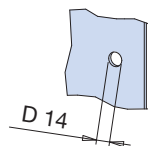

V-1105

- Coppia pomoli piatti Ø 55 mm.
- Pair of doorknobs Ø 55 mm.
- Paar Türknöpfe Ø 55 mm.

CS - NS - CR - OL - CP

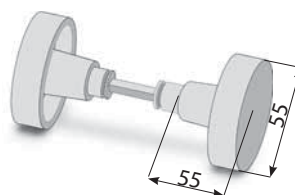

e▶ F.105

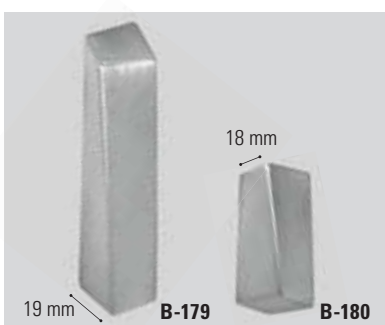
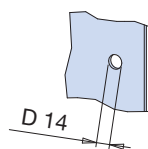

B-179

- Maniglia ad incollaggio biadesivo, versione lunga
- Small handle with selfadhesive fixing
- Kleine griffe selbstklebend

B-180

- Maniglia ad incollaggio biadesivo, versione corta
- Small handle with selfadhesive fixing
- Kleine griffe selbstklebend

CS - CR

e▶ B.318

e▶ B.319

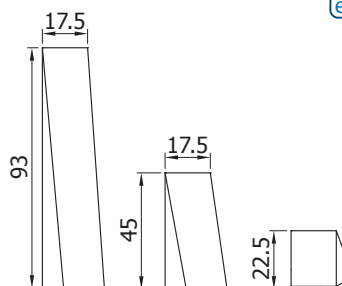

B-191-80 / B-191-240

- Maniglia ad incollaggio biadesivo.
- Small handle with self-adhesive fixing.
- Kleine griffe selbstklebend.

CR

		B-191-80	B-191-240
TL	80	•	
	240		•

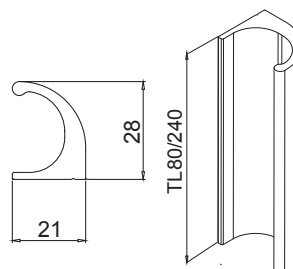

e▶ B.320

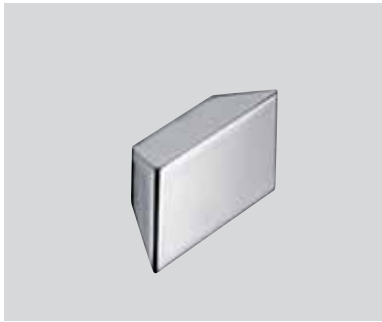

xme311

B-193

- Maniglia ad incollaggio biadesivo.
- Small handle with self-adhesive fixing.
- Kleine griffe selbstklebend.

CR

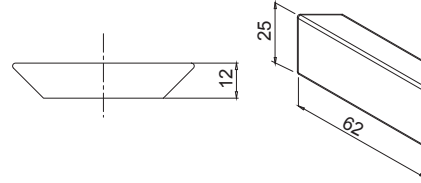

 e▶ **B.322**

xme311

B-170

- Nicchia tonda Ø 55 mm per scorrevole.
- Foro nel vetro Ø 45 mm.
- Materiale: ottone
- Sliding door-handle round Ø 55 mm.
- Hole in glass Ø 45 mm.
- Material: brass
- Rund Griffmuschel Ø 55 mm.
- Glas Bohrung Ø 45 mm.
- Material: Messing

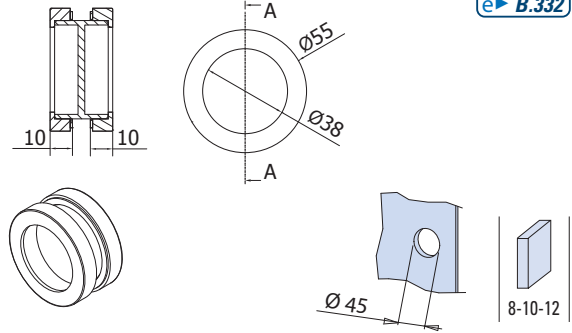
CR



 e▶ **B.322**

V-524

- Paio nicchie per scorrevole tonde, Ø 60
- Materiale: ottone
- Pair sliding door-handles, Ø 60
- Material: brass
- Paar Griffmuscheln, Ø 60
- Material: Messing

AN - NS - CR

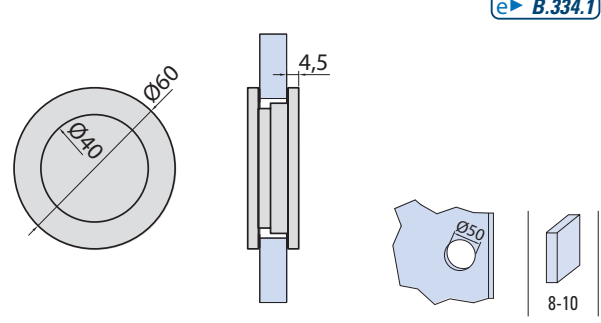
- **DISPONIBILE DA MAGGIO 2020**
- **AVAILABLE FROM MAY 2020**
- **VERFÜGBAR AB MAI 2020**

 e▶ **B.334.1**

V-526

- Nicchia chiusa.
- Closed sliding-handle.
- Griffmuschel geschlossen.

AN - CR - NS

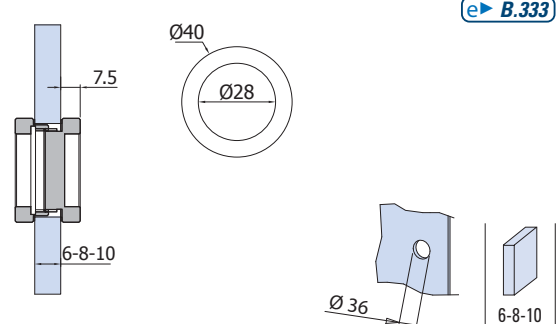
 e▶ **B.333**

V-528

- Nicchia chiusa.
- Closed sliding-handle.
- Griffmuschel geschlossen.

AN - CR - NS

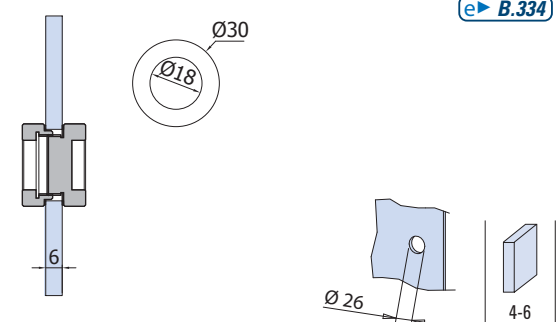
 e▶ **B.334**
NS
 Nickel satinato
 Satin nickel
 Ähnlich Edelstahl matt

CR
 Cromo lucido
 Polished chrome
 Chrom glänzend

CS
 Cromo satinato
 Satin chrome
 Chrom matt

OL
 Ottone lucido
 Polished brass
 Messing poliert

CP
 Cromo perla
 Chrome perla similar Alu
 Chrom perla ähnlich Alu

AN
 Alluminio anodizzato
 Aluminium anodized
 Aluminium Silberfarbig

MANIGLIONI AD INCOLLAGGIO

PULLHANDLES WITH SELF-ADHESIVE / STOSSGRIFFE SELBSTKLEBEND

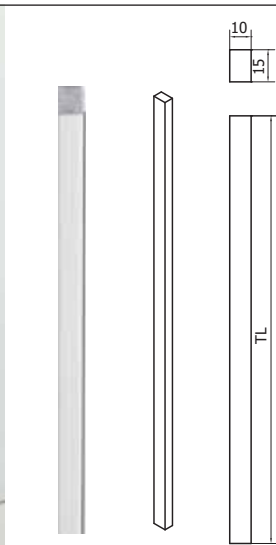

SQUARE 10

e▶ F.35

☐	Code	TL	Materiale Material	Unit.	Finitura Finishes Oberfläche
10 x 15	10.41.51/300	300	Ottone Brass Messing	Singolo Piece Stück	CR
10 x 15	10.41.61/300	300	Alluminio Aluminium Aluminium	Singolo Piece Stück	CR
10 x 15	10.41.71/300	300	Alluminio Aluminium Aluminium	Singolo Piece Stück	NO
10 x 15	10.41.51/500	500	Ottone Brass Messing	Singolo Piece Stück	CR
10 x 15	10.41.61/500	500	Alluminio Aluminium Aluminium	Singolo Piece Stück	CR
10 x 15	10.41.71/500	500	Alluminio Aluminium Aluminium	Singolo Piece Stück	NO

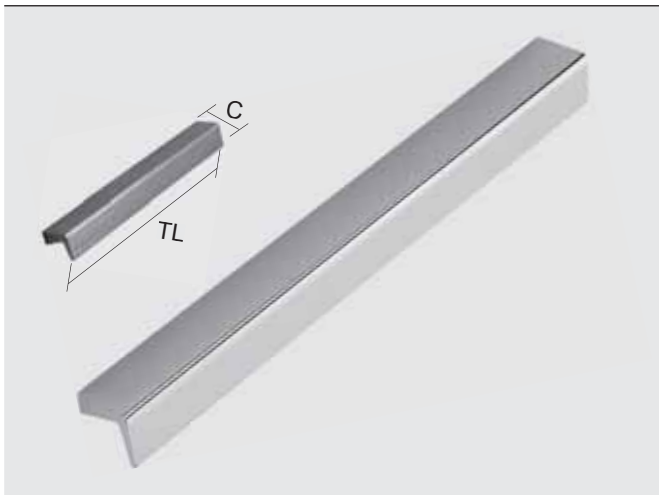

POR-0400 V

e▶ F.36

- Maniglione alluminio senza fori nel vetro ad incollaggio con biadesivo 3M
- Pullhandle in aluminium without holes in glass fixing with 3M self-adhesive
- Stossgriffe aus Aluminium ohne glasbearbeitung selbstklebend

TL	C	Unit.	Finitura Finishes Oberfläche
240	23	Singolo Piece Stück	AN
			CR
			NS
390	23	Singolo Piece Stück	AN
			CR
			NS
540	23	Singolo Piece Stück	AN
			CR
			NS

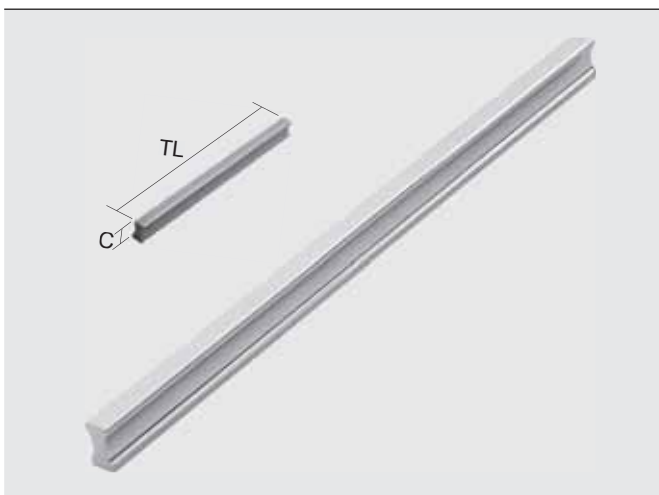

POR-0408 V

e▶ F.37

- Maniglione alluminio senza fori nel vetro ad incollaggio con biadesivo 3M
- Pullhandle in aluminium without holes in glass fixing with 3M self-adhesive
- Stossgriffe aus Aluminium ohne glasbearbeitung selbstklebend

TL	C	Unit.	Finitura Finishes Oberfläche
260	17	Singolo Piece Stück	AN
			CR
			NS
410	17	Singolo Piece Stück	AN
			CR
			NS
560	17	Singolo Piece Stück	AN
			CR
			NS



- 1**
- Pulire con solvente
 - Clean with solvent
 - Mit Lösungsmittel reinigen



- 2**
- Asciugare con un panno
 - Dry with a cloth
 - Mit einem Tuch trocknen



- 3**
- Staccare la pellicola protettiva e applicare
 - Remove the protective film and apply
 - Die Schutzfolie abziehen und anbringen

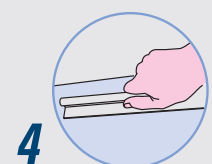

- 4**
- Premere con forza
 - Press firmly
 - Fest drücken

MANIGLIONI MINI Ø 16 - Ø 15

PULLHANDLES / STOSSGRIFFE



Square Alu Ø 14

e▶ **F.40**

- Maniglione. Materiale: Alluminio
 - Pullhandle. Material: Aluminium
 - Stossgriff. Material: Aluminium
- AN - CR



8-10-12



Round Mini Ø 16

e▶ **B.335**

- Maniglione inox
 - Pullhandle inox
 - Stossgriff inox
- IX - IL



8-10-12



Square Mini Ø 15

e▶ **B.338**

- Maniglione inox.
 - Pullhandle inox.
 - Stossgriff Inox.
- IX - IL



8-10-12

	TL	174	206	334	
	160	•			Ø 8,5
A	192		•		Ø 8,5
	320			•	Ø 8,5



	TL	225	300	
	135	•		Ø 9
A	200		•	Ø 9

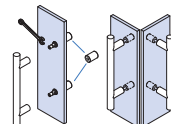

Option with
Knob **B-177**
page ▶ **171**

e▶ **B.336**

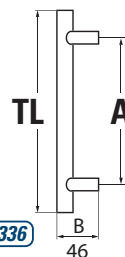

	TL	150	215	315	
	135	•			Ø 9
A	200		•		Ø 9
	300			•	Ø 9

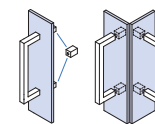

Option with
Knob **B-178**
page ▶ **171**

e▶ **B.339**

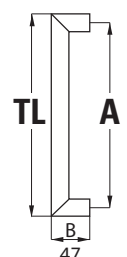

SQUARE 10

e▶ **B.340**

- Maniglione
- Pullhandle
- Stossgriff

AN - CR - NS



8

Ø	Code	A	TL		Materiale Material Material	Unit.	Finitura Finishes Oberfläche
10 x 15	10.41.53/290.300	290	300	8	Ottone Brass Messing	Paio Pair Paar	CR
10 x 15	10.41.63/290.300	290	300	8	Alluminio Aluminium Aluminium	Paio Pair Paar	CR
10 x 15	10.41.73/290.300	290	300	8	Alluminio Aluminium Aluminium	Paio Pair Paar	NO
10 x 15	10.41.53/490.500	490	500	8	Ottone Brass Messing	Paio Pair Paar	CR
10 x 15	10.41.63/490.500	490	500	8	Alluminio Aluminium Aluminium	Paio Pair Paar	CR



Foro vetro
Glass hole
Glasbohrung

IX

Acciaio inox satinato
Satin stainless steel
Edelstahl matt

CR

Cromo lucido
Polished chrome
Chrom glänzend

AN

Alluminio anodizzato
Aluminium anodized
Aluminium Silberfarbig

IL

Acciaio inox lucido
Polished stainless steel
Edelstahl poliert

NS

Nickel satinato
Satin nickel
Ähnlich Edelstahl matt

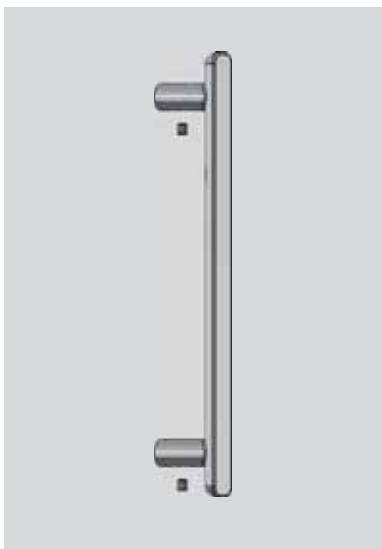

MANIGLIONI "ZAMA" PULLHANDLES ZAMAK / STOSSGRIFFE ZAMAK



SQ01 / SQ02

- Maniglione. Materiale: Zama
 - Pullhandle. Material: Zamak
 - Stossgriff. Material: Zamak
- CR

e► B.337

Code	A	TL		
SQ01	160	200	M4	Ø 6
SQ02	160	200	M4	Ø 6

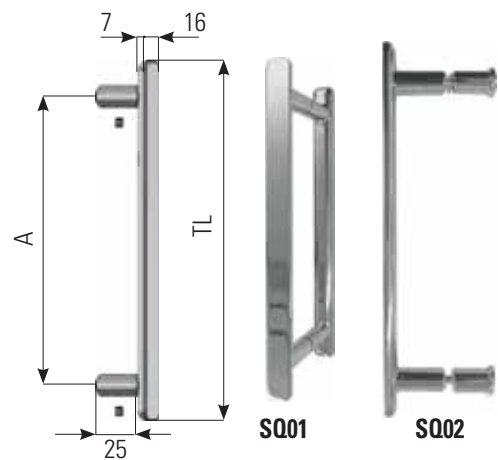

PORTASALVIETTE TOWEL BARS / HANDTUCHHALTER



B-120

- Portasalvietta montato a vetro L=600 mm, pomolino B-122 optional.
 - Glass mounted towel bar L=600 mm, knob B-122 optional.
 - Handtuchhalter für Glas L=600 mm, Knopf B-122 optional.
- CR

e► B.341

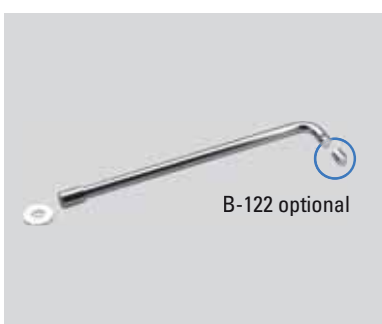
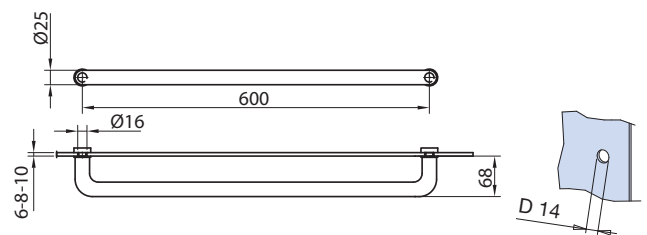

B-121

- Portasalvietta montato a vetro/muro L=600 mm, pomolino B-122 optional.
 - Glass/wall mounted towel bar L=600 mm, knob B-122 optional.
 - Handtuchhalter für Glas/Wand L=600 mm, Knopf B-122 optional.
- CR

e► B.342

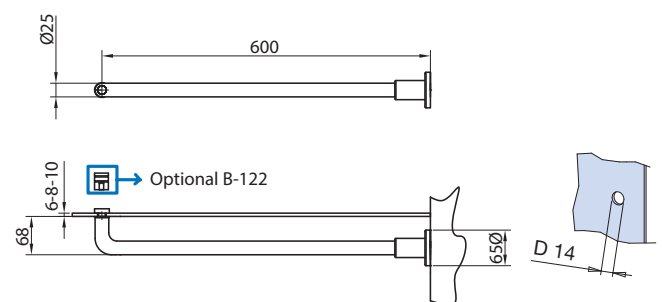

B-122

- Pomolo optional per portasalvietta.
 - Knob optional for towel bar.
 - Knopf optional für Handtuchhalter.
- CR

e► B.343

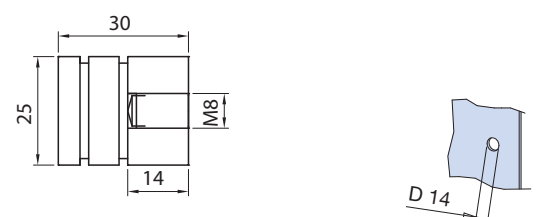

B-186
[e▶ B.345](#)

- Pomolo appendi salvietta montato a vetro.
- Knob towel bar for glass.
- Knopf Handtuchhalter, für Glas.

CR

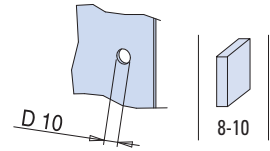
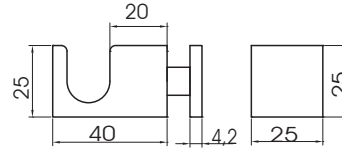
B-124
[e▶ B.344](#)

- Portasalvietta montato a vetro L-469 mm pomolino incluso.
- Glass mounted towel bar L-469 mm knob included
- Handtuchhalter für Glass L-469 mm Knopf enthalten

IL

B-125

- Portasalvietta montato a vetro L-619 mm pomolino incluso.
- Glass mounted towel bar L-619 mm knob included
- Handtuchhalter für Glass L-619 mm Knopf enthalten

IL

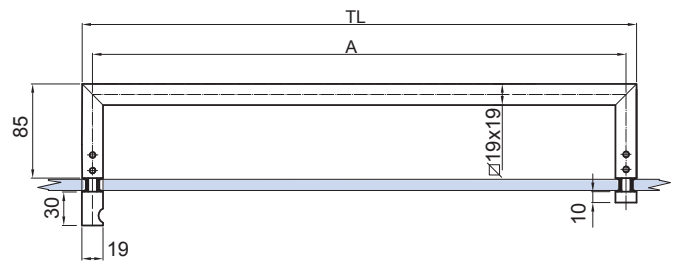

∅	Code	A	TL		Finitura Finishes Oberfläche	Materiale Material Material
19 x 19	B-124	450	419	10	IL	Inox Stainless steel Edelstahl
19 x 19	B-125	600	619	10	IL	Inox Stainless steel Edelstahl

PG-CHIAVE
[e▶ B.367.1](#)

- Chiave regolabile.
- Installation tool adjustable.
- Handwerkzeug Verstellbar.

 Foro vetro
 Glass hole
 Glasbohrung

IX

 Acciaio inox satinato
 Satin stainless steel
 Edelstahl matt

CR

 Cromo lucido
 Polished chrome
 Chrom glänzend

AN

 Alluminio anodizzato
 Aluminium anodized
 Aluminium Silberfarbig

IL

 Acciaio inox lucido
 Polished stainless steel
 Edelstahl poliert

- Le informazioni tecniche in questo catalogo potrebbero non sempre corrispondere con gli attuali colori, misure e dimensioni. Noi perseguiamo una politica di costante innovazione e miglioramento e ci riserviamo il diritto di modificare specifiche e disponibilità senza preavviso. Non abbiamo nessuna responsabilità per errori di stampa che possono essere occorsi nella realizzazione di questo catalogo. Essendo questo solo un catalogo grafico per la foratura del vetro bisogna fare riferimento al manuale tecnico.
- Please note that the technical information included in this catalogue may not always precisely correspond with actual colours, measurements and dimensions. We pursue a policy of constant updating and improvement and reserve the right to alter specification and availability without notice. We take no responsibility for any printing errors that might be occurred in the completion of this catalogue.
- Die in diesem Katalog angegebenen Maße, Abbildungen und Angaben, sind unverbindlich. Modelländerungen, Konstruktionsverbesserungen und Maßänderungen behalten wir uns vor. Erfahrungsgemäss können Druckfarben nicht immer den Farbton original getreu wiedergeben. Farbabweichungen sind daher möglich. Für Druckfehler wie auch übrige Fehler welche bei Erstellung dieses Kataloges entstanden sind, ist jede Haftung ausgeschlossen.

The first part of the document discusses the importance of maintaining accurate records in a laboratory setting. It emphasizes the need for clear labeling and organization of samples and equipment. The second part details the procedures for conducting experiments, including safety protocols and the use of standard operating procedures (SOPs). The third part covers the analysis of experimental data, highlighting the importance of statistical methods and the use of appropriate software tools. The final part discusses the reporting of results, including the preparation of lab reports and the presentation of data in a clear and concise manner.



METALGLAS BONOMI srl

Via Montini, 106/A - 25067 Lumezzane S.A. (Brescia) Italy
Ph. +39 030 829910 - Fax +39 030 8920970
www.metalglas.it - info@metalglas.it