

Front-mounted roller shutters

Front-mounted external venetian blinds

Technical data

Valid from 01/02/2013



WAREMA

Front-mounted roller shutters

Front-mounted external venetian blinds Technical data



General information

Technical catalogue, valid from 01/02/2013.

The publication of this brochure supersedes all previous corresponding documents.

For our general terms and conditions please visit our website www.warema.com under the heading "Imprint" or click on <http://www.warema.com/gtc> to view and download the file.

We reserve the right to make alterations in the interest of technical progress. Particular care was taken in producing the text and graphics of this document. No liability is assumed for any errors or consequences of such errors occurring in this documentation.

Our products are individual made-to-measure items and therefore cannot be exchanged or returned.

Safety instructions

Please see detailed information in the technical catalogue or in the installation and operating instructions.

Imprint

WAREMA Renkhoff SE
Hans-Wilhelm-Renkstoff-Strasse 2
97828 Marktheidenfeld
Germany

WAREMA and the WAREMA logo are registered trademarks owned by WAREMA Renkhoff SE. Other distinctive signs listed here are marks or registered trademarks held by their respective owners.

© WAREMA Renkhoff SE

Overview	12	Overview
Front-mounted roller shutters V4	35	Front-mounted roller shutters V4
Front-mounted roller shutters V6	45	Front-mounted roller shutters V6
Front-mounted roller shutters V10	55	Front-mounted roller shutters V10
Determining dimensions/operating details – Front-mounted roller shutters	67	Determining dimensions/operating details
Additional options	93	Additional options
Guide and end rails	107	Guide and end rails
Security roller shutters – FR 23/FR 24	121	Security roller shutters
Front-mounted external venetian blinds – R6/R10	133	Front-mounted external venetian blinds
Accessories for front-mounted roller shutters Roller shutter curtains	171	Accessories Roller shutter curtains
Control systems	185	Control systems

Service, quality and reliability.



As market leader for sun shading systems WAREMA consciously prioritises innovations which are tailored to market requirements. In addition to the constant expansion of our product range this also includes the extraordinary quality of our products and our services, allowing us to offer an integrated product portfolio with comprehensive consulting services. Our claim is to deliver as soon as possible – with individual manufacturing. You can see that WAREMA is a partner you can fully rely on.

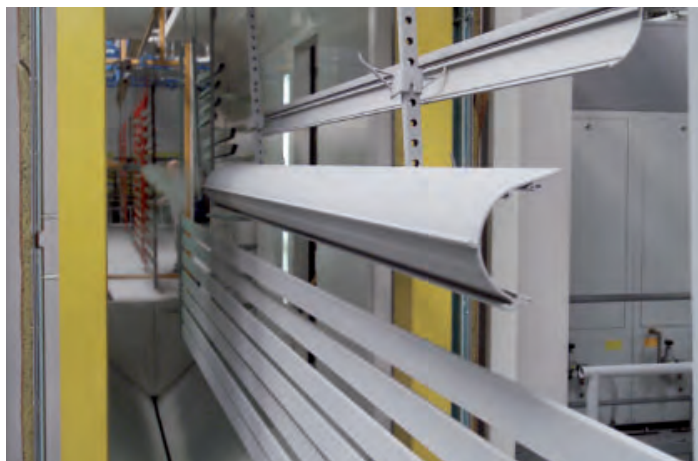

Our production equipment is developed and built mainly by our subsidiary WAREMA Kunststofftechnik und Maschinenbau GmbH. It is this independence that enables us to quickly react to changes on the market and adapt our products directly to the new requirements.

But WAREMA is not just unique with the products we offer: In addition to individual custom solutions we also stand for first rate quality management and a sustainable environmental approach. We check all materials for quality as well as recyclability.

We have a well established national and international network. More than 100 international advisers can offer support for worldwide projects in more than 48 countries. Numerous planning tools are available online. So you can be sure to always receive an answer to your questions.



Room climate intelligently controlled – the WAREMA system concept.

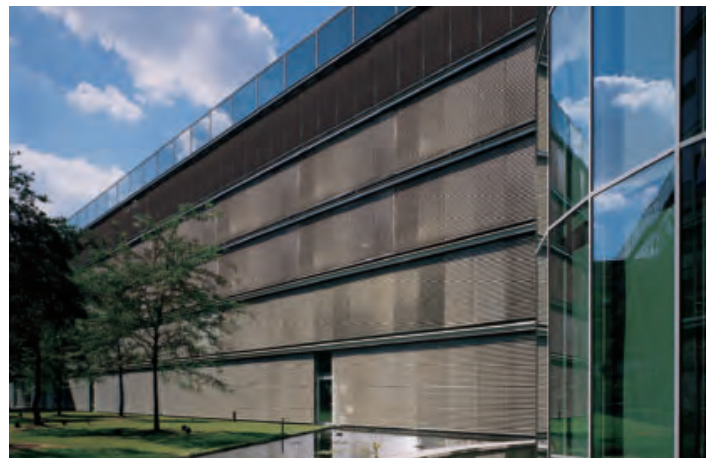
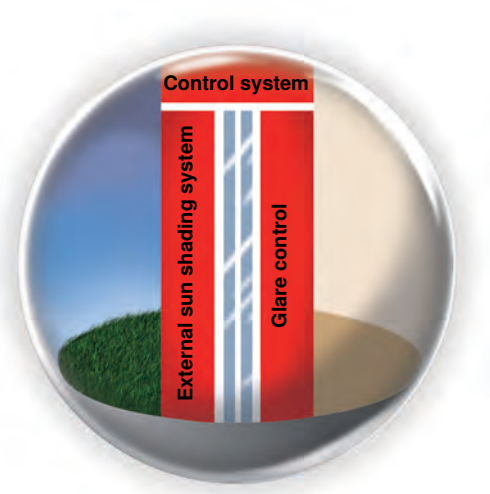

The OPTI SYSTEM

External sun shading system

External WAREMA sun shading systems reduce incidence of light and optimise the use of solar energy. The principle is simple: Depending on time of day or year more or less sunlight is allowed in and the system uses more or less of the possible solar energy gain.

Internal sun shading system

The internal WAREMA product provides additional glare control all year round and reduces cold loss through the glazing, providing comfort and high convenience. Visual privacy or view out can be individually adjusted. High-grade materials and a varied colour palette give individual style to any room.

Intelligent control

WAREMA control systems create the best possible room climate and ensure solar energy gain according to demand.

This is ensured by optimised incidence of light, adjusted to the current weather situation. And all this around the clock.



Best possible sun shading systems and distinct energy savings are an interesting aspect for any home owner today. The WAREMA OPTI SYSTEM offers the ideal room climate – comfortable cool in summer and cosy warm in winter. Fully automatic with maximum comfort. With existing heat protection glazing the combination of external adjustable sun shading, internal glare control and an intelligent control saves up to 40 percent of energy costs.

Further information can be found at www.warema.com/optisystem

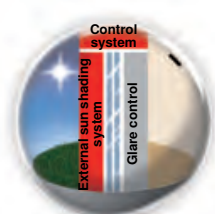

Summer daytime

On a hot summer day the sun has to be mostly shut out in order for the building to remain comfortably cool. The external sun shading reduces incidence of light and allows glare-free working.



Summer night time

At the end of a hot summer day the building will have heated up. At night the control raises all existing sun shading components. This supports the building cooling down.

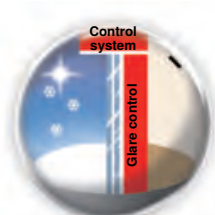

Winter daytime

On a cold winter day only the internal glare control is used. Due to the low sun the requirement on this are particularly high. Dark, absorbent colours ensure that a large quantity of solar energy can be used.



Winter night time

During the cold winter night the building has to be protected from heat loss. This requires all sun shading products to be lowered. The resulting air pockets between the individual components improve heat insulation.

vivamatic®

Daylight management for external venetian blinds

vivamatic® Daylight management for external venetian blinds

- **Maximum daylight utilisation** without darkening the room already during lowering (user remains undisturbed)
- **Best possible room illumination** plus heat protection
- **Reduced use of artificial light** and no artificial light required for the short period of lowering the external venetian blinds
- Continuous, **automatic readjustment** of the slat angle provides permanent feel-good atmosphere – for the whole day
- **Comfortable control** using WAREMA climatronic® 2.0
- **Reduces energy consumption** for air conditioning of the building and increases energy efficiency. Sustainably.

Available from February 2013
www.vivamatic.com



vivamatic® cannot be seen. But you can see the result: The intelligent daylight management always ensures best possible light utilisation. The external venetian blind slats are always set to the appropriate angle. This improves energy efficiency while maintaining maximum comfort so you can enjoy tomorrow's quality of life today.

Maximum comfort and energy efficiency with vivamatic®

A day with vivamatic® Late morning the external venetian blind slats are wide open. The room is flooded with daylight. It is comfortably bright. Sunshine creates excitement about what the day will bring. In the afternoon, half-shade protects the eyes. The sun is high in the sky but glare remains outside. The air conditioning is idle. Artificial lighting? Remains switched off. In the evening the slats are still at the correct angle. Not one single manual adjustment. That is vivamatic® – the intelligent daylight management for external venetian blinds with maximum comfort and energy efficiency.

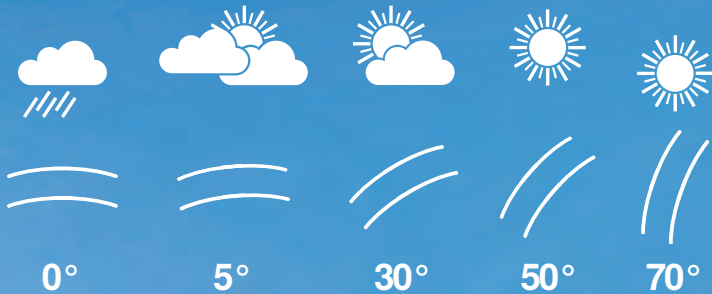

Always at the perfect slat angle



New products 2013

Front-mounted roller shutters

Front-mounted external venetian blinds



Front-mounted roller shutters with Minimax guide rails

The steadily growing trend towards increasingly filigree window designs prompted the new product development in our roller shutter range: From February 2013, our front-mounted roller shutters V6 and V10 will be available with new slim guide rails. New so-called "Minimax" guide rails with a reduced width of only 37 mm will be available in addition to the standard guide rails with a visible width of 55 mm; once under plaster, the visible width is even reduced to just 22 mm. This guide rail is an absolute unique selling point on the market!

What is more, the reduction of the Minimax guide rail width permits additional lateral insulation that results in added energy-related benefits. There are no limitations as to wind class or construction limit values, and these roller shutters are also available with insect screen. This also results in an even better compatibility of front-mounted roller shutters and front-mounted external venetian blinds with an almost identical guide rail width of 39 mm.

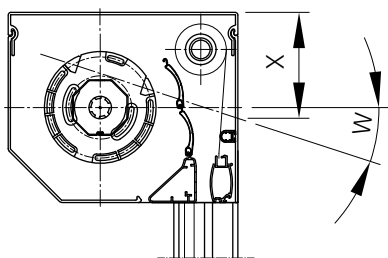

Improved crank outlet

With the publication of the new sales documents a type 1 crank returns to our front-mounted roller shutter range. The new crank is used for shutter surface areas of up to 5.0 m²; crank type 2 is used for all larger shutter areas, as before. With its 6:1 worm gear, crank type 1 offers a larger crank outlet, and thus higher flexibility. The robust design with metal cogwheels is an impressive indicator for sturdiness and durability.



Extension of construction limit values for plastic roller shutter curtains

As of today, the roller shutter curtain K 36 can be supplied with a maximum width of up to 2000 mm or a surface area of 3.2 m², respectively, across all shutter types.

Discontinued products

The WAREMA Visio® will no longer be available after the publication date of this brochure.

If you stop striving to become better you also stop being good - this is the WAREMA quality claim in a nutshell. It is not just about providing our customers with high-grade materials and first-rate workmanship; we want more.

In addition to our strict quality management we make sure our products and services are consistently adapted to our customers' changing needs. The result is a unique range of modern solutions for a large variety of applications. Numerous awards (e.g. Innovation Prize R+T), seals of quality and patented products show us that we are on the right track.

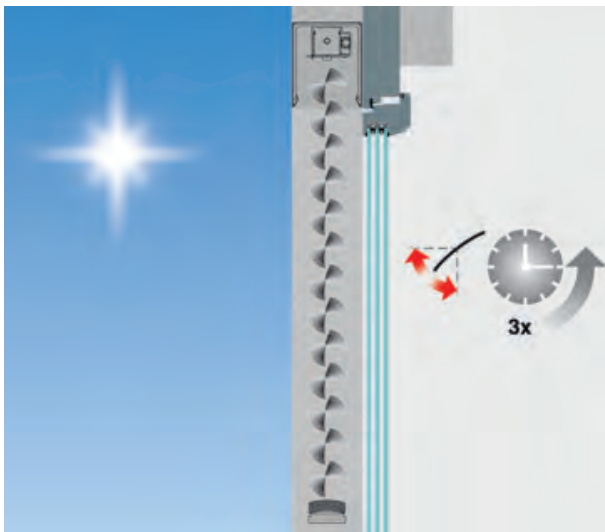

More exact slat positioning = improved energy efficiency

External venetian blinds with the additional function slowturn feature a reduced slat tilting speed.

The available time is tripled compared to standard external venetian blinds, achieving a more precise positioning of the slats.

Using a higher-level sun shading control system allows slowturn to sustainably improve the energy efficiency of the building.

Front-mounted roller shutters/front-mounted external venetian blinds – security plus sun shading



Front-mounted roller shutters

WAREMA front-mounted roller shutters are suitable for retrofitting. For example when a refurbishment or renovation project is being carried out with high demands on thermal and sound insulation as well as security. Front-mounted roller shutters are also becoming increasingly popular for preventing thermal bridges in new buildings. WAREMA front-mounted roller shutters with many different available models are true all-rounders. In addition to the basic functions of a roller shutter they also incorporate protection against annoying insects and can be installed with optional solar drives. The insect screen, whether as integrated roller blind or as an insect screen swivel frame, can be used independently of the roller shutter curtain. The innovative solar drive combines all the advantages of a front-mounted roller shutter with the benefits of solar technology. Uncomplicated installation is ensured – no wall openings or connecting work required. Front-mounted roller shutters can either be "invisibly" integrated into the facade or used as a highlight for the facade design.



Security roller shutters

WAREMA security roller shutters offer particularly effective burglary protection. The security roller shutter has been certified with the seal of approval for burglar resistant properties of resistance class WK 2 by an independent test institute. This certification was achieved with the special security design of the product and the additionally reinforced components.

Front-mounted external venetian blinds

WAREMA front-mounted external venetian blinds combine great practical value, state-of-the-art technology and modern design with the visual impression of front-mounted roller shutters. Especially in residential rooms they act as a light regulator to provide reliable sun shading and sufficient privacy. It is up to you to decide how much: Customisable with an electric motor or with the reliable WAREMA controls. With every convenience! Whether you are planning to equip your home with external sun shading systems, e.g. when refurbishing, or whether you would simply like to use the front-mounted external venetian blinds as a visual element of facade design – there are no limits to your personal requirements where shape, colour and technology are concerned.



Saving energy and creating the best possible indoor climate – these are the key issues of modern architecture. They are becoming ever more important particularly for the renovation of existing buildings. WAREMA front-mounted roller shutters can offer the perfect solution for heat and sound insulation. And of course security is taken into consideration as well. Front-mounted roller shutters can either be unobtrusively integrated into the facade or used as a prominent design feature. In either case they provide reliable visual privacy and sun shading. Discover the wide range of possibilities!



Asymmetrical roller shutters

WAREMA asymmetrical roller shutters are the made-to-measure solution for modern windows with diagonal glazing. Special locking clips, dedicated guide rails and the special technology inside the shutter box guarantee smooth operation.



Top-mounted roller shutters

WAREMA top-mounted roller shutters are used for new buildings or during window renovations. In contrast to front-mounted roller shutters the box of top-mounted roller shutters is placed on the window element. Roller shutter and window are mounted together.



Renovation roller shutters

Renovation roller shutters are the solution for improving the heat insulation of existing lintel boxes when replacing windows. Mounted to the window beforehand, both components can be installed in the window opening and the lintel box in one time-saving step.

For further information and the complete range of WAREMA top-mounted and asymmetrical roller shutters please refer to the individual documents or under www.warema.com.

Perfection

Technology in detail

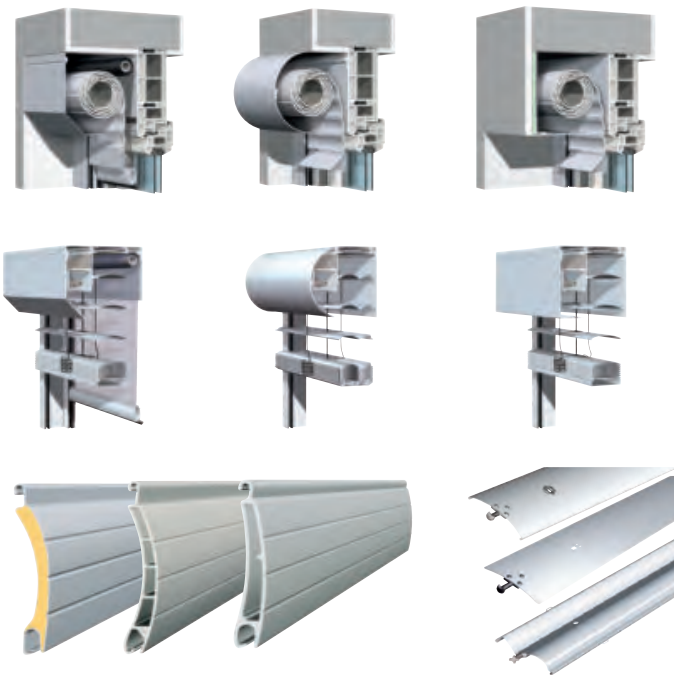

Box

Depending on type the box is available closed on three or four sides in extruded or roll-formed/folded versions. The box is available rectangular, round, square or "invisibly" embedded in plaster. The triangular design end rail gives roller shutters with belt and crank operation an attractive cover. On motor operated units it provides almost flush closure.

The integrated insect screen roller blind provides protection against annoying insects. Types V4 and V6 allow retrofitting of insect screens while they are already included in V10.

Benefit from the high degree of flexibility of our range of front-mounted roller shutters and external venetian blinds during planning and later on.

Roller shutter curtain/external venetian blind slats

WAREMA offers a variety of high-quality roller shutter profiles. Depending on requirements and application there are different types of profiles to choose from. WAREMA offers the perfect solution for each situation, providing different properties such as stability and winding behaviour. For front-mounted external venetian blinds you can choose between 80 mm beaded slats, 80 mm flat slats and 73 mm dim-out slats.

Colours for roller shutter profiles/external venetian blind slats



Crank drive



WAREMA generally supplies units with crank drive with thermal separation.

WAREMA pivot bearings with patented thermal separation reduce energy loss for the crank drive resulting from air exchange and heat transfer by 50 % compared to standard pivot bearings (verified by an independent institute). The thermal separation of the

drive rod increases the surface temperature of the pivot bearing and reduces heat conduction in the pivot bearing rod. Together with the sealing of the pivot bearing plate preventing air exchange even on uneven mounting substructures this works to prevent the formation of condensation.

Quality that is recognisable at first sight: WAREMA roller shutter curtains are manufactured with uncompromising perfection. They are available as plastic or aluminium versions, differing in rigidity and winding properties. Furthermore countless colours are available for boxes, guide rails and curtains. Select your favourite combination according to you personal taste.

Operation

WAREMA offers a large selection of operation and control variants. For roller shutters you can choose between classic belt, cord or crank operation or modern and convenient motor drive.

The innovative technology in the box allows simple and cost-efficient change of the operating type at any time. Front-mounted external venetian blinds can be operated by crank and motor.



Motor

- easy operation for all sizes
- standard motor with torque overload protection
- EWFS radio motor available

Belt/cord

- reasonably priced option
- sufficient for small roller shutters
- different belt winders available

Crank

- with thermal separation
- for medium-sized roller shutters
- detachable crank rod available



Minimax guide rail

- slim design with a visible width of only 37 mm (instead of 55 mm)
- ideal for the use of filigree window frames
- also available with insect screen
- no technical limitations when compared to standard guide rails
- visible design almost identical to front-mounted external venetian blinds, providing an even better optical compatibility



Solar drive

- solar energy is stored in the battery
- drive via 12 V motor
- convenient operation with 1-channel EWFS radio hand transmitter included
- easy installation, no electrical connection required
- concealed battery and control system
- available for front-mounted roller shutters V10 and front-mounted external venetian blinds R6/R10

Control systems

WAREMA sun shading control systems offer the perfect solution for any application. For example manual operation via hand-held radio transmitter. This allows controlling of roller shutters with EWFS radio motors or front-mounted external venetian blinds using the EWFS plug receiver. WAREMA offer a large variety of automatic control systems. Especially the WAREMA ComfortTimer helps to increase security of your building and offers additional convenience for the user. Ideally, the motorised sun shading systems are effectively positioned automatically at just the right time – even when you are not at home.



Colours

Feel and live

Colours for powder-coated aluminium parts

The complete range of the RAL CLASSIC colour chart (except camouflage and luminous colours) as well as the DB colours 701, 702 and 703 and further colours according to the WAREMA standard colour fan are available for the powder-coated aluminium parts of our roller shutters and external venetian blinds.

Additionally there is a choice of anodised-look colours as well as 8 structural colours with a textured coating with metallic look, according to WAREMA colour specification.

There are no limits to colour features and colour blending options on the facade!

The exceptional coating quality ensures durability – independently tested by the Quality Association for the Coating of Building Materials (GSB). The surface coating with chrome-free pre-coating corresponds to the directive GSB AL 631.

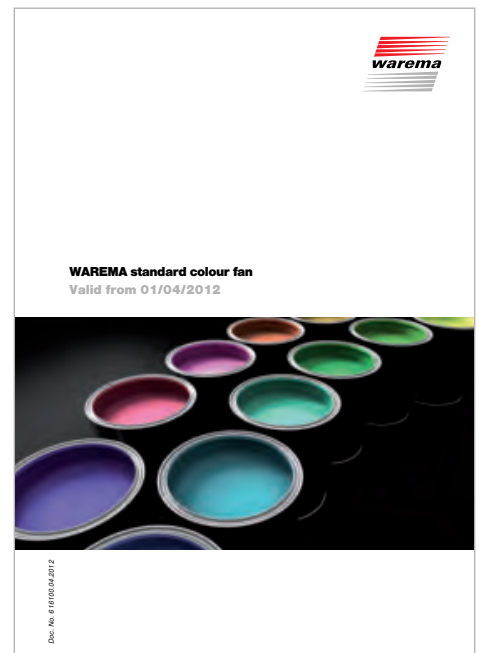

Doc. No. 6 16105-04-2012



WAREMA structural colours

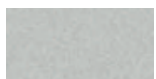

MS white aluminium
W 4914

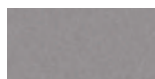

MS grey aluminium
W 4915



MS anthracite
W 4916

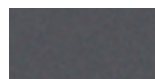

MS black grey
W 4917

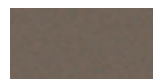

MS sepia brown
W 4918



MS earth brown
W 4919



MS steel blue
W 4920



MS dark green
W 4921

Overview

Colours for roller shutter profiles/external venetian blind slats

Colours for roller shutter profiles/external venetian blind slats			Price category	Roller shutter profiles					External venetian blind slats			End rail colour Standard end rail colour when ordering curtain (not applicable for ordering prefabricated elements)	
				A 36	A 44	A 53	A 56	S 37 ¹⁾	80 A6	73 A6	80 AF		
Aluminium													
RAL 1015	Light ivory		1	●	●	●	●	●	●	●	●	C0 anodised	
RAL 1019	Grey beige		2	●						●	●	C0 anodised	
RAL 1036	Pearl gold		2	●						●	●	C0 anodised	
RAL 3004	Purple red		1	●						●	●	C0 anodised	
RAL 5011	Steel blue		1	●						●	●	C0 anodised	
RAL 6009	Fir green		1	●						●	●	C0 anodised	
RAL 7016	Anthracite grey		1	●	●	●				●	●	C0 anodised	
RAL 7035	Light grey		1	●	●	●	●	●		●	●	C0 anodised	
RAL 7038	Agate grey		1	●	●	●	●	●		●	●	C0 anodised	
RAL 8014	Sepia brown		1	●	●	●	●	●		●	●	RAL 8014	
RAL 9006	White aluminium		1	●	●	●	●	●		●	●	C0 anodised	
RAL 9007	Grey aluminium		1	●						●	●	C0 anodised	
RAL 9010	Pure white		1	●						●	●	C0 anodised	
RAL 9016 ²⁾	Traffic white		1	●	●	●	●	●		●	●	RAL 9016	
DB 502	Blue iron mica effect		2	●						●	●	C0 anodised	
DB 603	Green iron mica effect		2	●						●	●	C0 anodised	
DB 702	Grey iron mica effect		2	●						●	●	C0 anodised	
DB 703	Anthracite iron mica effect		1	●						●	●	C0 anodised	
W 3005	Wine red pearl mica effect		2	●						●	●	C0 anodised	
W 4800	Light beige		2	●	●	●	●	●		●	●	C0 anodised	
W 4919	Earth brown iron mica effect		2	●						●	●	C0 anodised	
W 4922	Cappuccino		2	●						●	●	C0 anodised	
W 7329	Dark bronze		1	●						●	●	C0 anodised	
W 8000	Selective slat		3							●	●		
W 8026	Wood dark		2	●	●	●	●					RAL 8014	
W 8100	Millfinish II		3							●	●		
W 8105	Wood light		2	●	●	●	●					C0 anodised	
W 8780	Light bronze		1	●						●	●	C0 anodised	

¹⁾ for roller shutter profile S 37 no price group differentiation within the colour chart. powder coating not included in this colour chart, also in accordance with standard WAREMA colour chart, available at a surcharge!









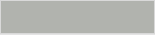

²⁾ similar to RAL 9016 for roller shutter profiles

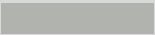
Colour variations are a result of the printing process.

Owing to the different manufacturing processes, colour differences between roller shutter curtains or external venetian blind slats and powder-coated aluminium parts are unavoidable.

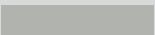
Overview

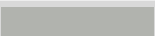
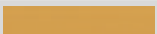
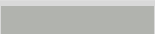
Colours for roller shutter profiles

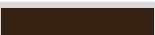
Colours for roller shutter profiles			Price category	Roller shutter profiles				End rail colour Standard end rail colour when ordering curtain (not applicable for ordering prefabricated elements)	
				K 36	V 36	K 52	K 55		
Plastic									
500	Agate grey		1	●	●	●	●	C0 anodised	
501	Light grey		1	●	●	●	●	C0 anodised	
510	Traffic white		1	●	●	●	●	RAL 9016	
515	Light ivory		1	●	●			C0 anodised	
522	Light beige		1	●	●	●	●	C0 anodised	
541	Wood light		1	●		●	●	C0 anodised	
543	Wood dark		1	●				RAL 8014	

Colour variations are a result of the printing process.

WAREMA sun shading planner

The WAREMA sun shading planner will help you to plan your sun shading system and appropriate control system quickly and reliably. Short descriptions and application examples help you with choosing your system. Use the sun shading planner to generate your own drawings, with your own dimensions and the correct measurements. You will find the right texts for quotation in the generated solution in the sun shading planner or at www.warema.com under the heading **Services/Texts for Quotation**.

The information can be output in all common file formats or it can be transferred directly to your design software. This system is interactive and platform-independent; installation on your computer is not necessary. You can find the current version online under www.sonnenschutzplaner.de



To use the sun shading planner offline it can be downloaded and updated over the internet.

Order forms

You can find all order forms on the Order Forms CD (which can be ordered by sending doc. No. 939904 to werbemittel@warema.de) or as free downloads at www.warema.com in the **Customer Network under Online Order (WOS) – Order Forms**. Or use our WAREMA Online Services for easy and convenient online ordering.



CE marking

CE declarations of conformity are available for all external sun shading products as well as for motor-operated internal units (230 volt). The products conform to DIN EN 13659:2009-01 (external venetian blinds/roller shutters), DIN EN 13561:2009-01 (awnings) or DIN EN 13120:2009-04 (internal sun shading systems). These standards govern the requirements for external and internal sun shading systems and form the basis for the CE marking.

All electrical drives used are certified in line with current applicable standards and carry the respective markings.



All WAREMA products are designed for especially high durability. All WAREMA products meet durability classes 2 or 3 of the standard, which are set by European standards.

Without exception all WAREMA external venetian blinds fulfil the highest durability class (3) according to DIN EN 13659, tested according to DIN EN 14201, with 10000 movements and a total of 20000 slat turns.

Assuming two movement cycles per day this is equivalent to an expected working life of at least 15 years.

Quality has a name



Every original WAREMA external venetian blind is clearly but elegantly and unobtrusively marked with a logo embossing on one of the lower slats,



WAREMA roller shutters are marked with a high-quality logo sticker that is applied on the side of each end rail,

making original WAREMA quality immediately and unmistakably visible.

Contents

Roller shutters

General

Wind resistance classes according to DIN EN 13659	22
Operating classes according to DIN EN 13659	24
Requirements for external sun shading systems	26
Type key/type matrix	29
Overview of accessories/equipment	30

Wind resistance classes according to DIN EN 13659

Roller shutters

In effect since 01/04/2006

The new standard DIN EN 13659 has been in force since 01/04/2006. According to the standard all roller shutters have to bear a CE marking after this date. Please note the following points!

To determine which wind resistance class is required for which application, an ift guideline has been created on instructions of the Bundesverband Rollladen und Sonnenschutz. This guideline "Recommendations for use of exterior covers" divides the area of Germany into wind load zones (1) and terrain categories (2). The relevant wind load zone and terrain category can then simply be derived from the location of the building. The installation height (3) of the covers provides the third required value.

1. Determining the wind load zone



2. Determining the terrain category

Terrain category I

Open sea, lakes with at least 5 km free space in the direction of the wind; flat even land with no obstacles

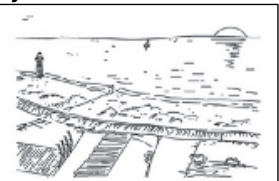

Terrain category II

Terrain with hedges, individual farmsteads, houses or trees, e.g. farming areas



Terrain category III

Suburbs, industrial and commercial areas; forests



Terrain category IV

Urban areas where at least 15% of the area is covered with buildings having an average height of more than 15 m.



Source: DIN 1055-4:2005-03

	Wind load zone	Wind speed (m/s)	Wind force
	1	22.5	9
	2	25.0	9-10
	3	27.5	10
	4	30.0	11

Source: DIN 1055-4:2005-03

3. Installation height

Using the installation height the recommended wind resistance class can be read from the following table from the ift guideline:

Terrain category	Requirements	Installation height of the covers at average 0-8 m				Installation height of the covers at average >8-20 m				Installation height of the covers at average >20-100 m			
		Wind load zone				Wind load zone				Wind load zone			
		1	2	3	4	1	2	3	4	1	2	3	4
I	Wind resist. class	3	4	4	4	4	4	5	5	4	5	5	6
II	Wind resist. class	3	3	4	4	3	4	4	5	4	5	5	5
III	Wind resist. class	2	3	3	4	3	3	4	4	4	5	5	5
IV	Wind resist. class	2	3	3	3	3	3	3	4	4	4	4	5

Tab. 1: Installation height

A separate proof for the classification has to be provided for installation heights of external covers above 100 m, for buildings with a non-rectangular footprint and for buildings which are built above a terrain level of 800 m. The given values are reference values.

The minimum class for recommended use is wind resistance class 2. Roller shutter curtains for lower wind resistance classes can be used when the local situation is well known. However, we recommend the use of a product of the

relevant wind resistance class to set a certain standard of quality.

Wind resistance classes according to DIN EN 13659

Roller shutters

Wind strength – stating wind resistance classes

According to DIN EN roller shutters have to be provided with a wind resistance class. 7 wind resistance classes (0 to 6) are available. Wind resistance class 0 is given if class 1 was not achieved or if the wind resistance class was not tested.

For determining the wind resistance class the relevant pressure from the above table is applied to the roller shutter curtain. This has shown that wind resistance mainly depends on the type of roller shutter profile, the guide rail/the immersion depth as well as the width of the roller shutter.

The following table shows the maximum width achievable for each wind resistance class for the individual roller shutter profiles and the guide rails used in each case.

Changing the roller shutter profile or the guide rail can possibly lead to achieving a higher wind resistance class.

Wind resistance class	Rated test pressure p in N/m ²	Safety test pressure 1.5 p in N/m ²
0	< 50	< 75
1	50	75
2	70	100
3	100	150
4	170	250
5	270	400
6	400	600

Tab. 2: Wind resistance class

WAREMA asymmetrical roller shutters generally comply with wind resistance class 0, since there is no suitable measuring procedure for these products and they can therefore not be tested.

WAREMA security roller shutters FR 23/FR 24 with guide rail FSCH 75-52 achieve wind resistance class 6 for all curtain sizes.

Max. order width for roller shutters for each wind resistance class in mm

Roller shutter curtains	Max. order width for roller shutters for each wind resistance class in mm							Valid when using the guide rail																
	0	1	2	3	4	5	6	front-mounted V4/V6						V10										
								55-25	55-35	55-47	55-46	55-45	55-65	55-75	55-85	37-25	37-46	55-48	55-52	37-48				
A 36	3000	2780	2705	2560	2265	1825	1500	X	X	X	X	X	X	X	X	X	X	X	X	X	X	X	X	X
A 44	3500	3295	3200	3010	2625	2055	1600	X	X	-	-	X	X	X	X	X	X	-	X	X	X	X	X	
A 53	3800 ¹⁾	3635 ¹⁾	3545 ¹⁾	3370	3020	2490	1790	X	X	-	-	X	X	X	X	X	-	-	-	-	-	-	-	
A 56	4500 ¹⁾	3900 ¹⁾	3775 ¹⁾	3535 ¹⁾	3050	2330	1360	-	-	-	-	-	-	-	-	-	-	-	-	-	-	-	-	
S 37	-	-	-	3000	2790	2375	1820	X	X	-	-	X	X	X	X	X	-	X	X	X	X	X	X	
K 36	1800	1785	1685	1495	1110	535	-	X	X	X	X	X	X	X	X	X	X	X	X	X	X	X	X	
V 36	2200	2155	2065	1890	1535	1010	-	X	X	X	X	X	X	X	X	X	X	X	X	X	X	X	X	
K 52	2500	2355	2285	2140	1855	1425	850	-	-	-	-	-	-	-	-	-	-	-	-	-	-	-	-	
K 55	3300 ¹⁾	3125	2825	2220	1015	-	-	-	-	-	-	-	-	-	-	-	-	-	-	-	-	-	-	

Tab. 3: Max. order width for roller shutters for each wind resistance class in mm

¹⁾ Max. widths for roller shutter curtains(does not apply in connection with front-mounted roller shutters).

Note: Wind resistance classes for the reinforced guide rails from the security package can be found on page 95.

Changing the guide rails results in the following upwards (+1) or downwards (-1) shift of the wind resistance classes:

Roller shutter curtain	Shift for guide rail	
	46-25, 46-35, 46-85	80-25
A 36	-1 ¹⁾	+1
A 44		+1
A 53		+1
A 56		
S 37		
K 36	-1 ²⁾	+1
V 36	-1 ¹⁾	
K 52		
K 55		

Tab. 4: Shift of wind resistance classes

¹⁾ max. width 1800 mm

²⁾ max. width 1500 mm

Operating classes according to DIN EN 13659

Roller shutters

Operating forces

DIN EN 13659 states two possible operating classes for each maximum permitted operating force, depending on the different operating types.

We recommend compliance with operating class 1 or 2 in accordance with DIN EN 13659. These represent the current state of the art. If required, WAREMA can – in deviation from this – provide larger dimensions according to the table below, within the framework of technical feasibility. However, exceeding these dimensions is always at the customer's sole risk. As an alternative for keeping up with the state of the art, the drive type can be changed, e.g. by using a motor.

The following table shows the maximum areas according to DIN EN 13659 for both operating classes as well as the design limits for maximum areas for each operating type.

Operating type		Operating force in N	
		Class 1	Class 2
Crank or operation with winch		30	15
Belt		90	50
Cord or chain		50	25
Rod operation	vertical	90	50
manual operation	horizontal or diagonal	50	30

Roller shutter curtain	Operating class	Maximum area for each operating type in m ²								
		Cord	Belt internal	Belt with pull-out belt disc	Belt deflection	Step-up gear for belt (box size 14.5 or larger)	Crank winder for belt	Crank type 1, internal	Crank type 2, internal	Crank with pull-out gear
A 36 (2.7 kg/m ²)	design-related	2.0	4.0	3.0	3.0	8.0	6.0	5.0	8.0	3.0
	operating class 1	1.0	2.0	2.0	2.0	4.0	3.0	5.0	8.0	3.0
	operating class 2	0.5	1.0	1.0	1.0	2.0	1.5	3.0	5.5	3.0
A 44 (2.9 kg/m ²)	design-related	1.5	4.0	3.0	3.0	7.0	6.0	5.0	8.0	3.0
	operating class 1	1.0	2.0	2.0	2.0	4.0	3.0	5.0	8.0	3.0
	operating class 2	0.5	1.0	1.0	1.0	2.0	1.5	2.5	4.5	2.5
A 53 (3.1 kg/m ²)	design-related	1.5	3.0	2.0	2.0	6.0	5.0	4.0	7.0	2.0
	operating class 1	1.0	2.0	2.0	2.0	4.0	3.0	4.0	7.0	2.0
	operating class 2	0.5	1.0	1.0	1.0	2.0	1.5	2.5	4.5	2.0
S 37 (6.3 kg/m ²)	design-related	-	-	-	-	-	-	-	3.5	-
	operating class 1	-	-	-	-	-	-	-	3.5	-
	operating class 2	-	-	-	-	-	-	-	-	-
K 36 (2.9 kg/m ²)	design-related	1.5	4.0	3.0	3.0	7.0	6.0	5.0	8.0	3.0
	operating class 1	1.0	2.0	2.0	2.0	4.0	3.0	5.0	8.0	3.0
	operating class 2	0.5	1.0	1.0	1.0	2.0	1.5	2.5	4.5	2.5
V 36 (2.9 kg/m ²)	design-related	1.5	4.0	3.0	3.0	7.0	6.0	5.0	8.0	3.0
	operating class 1	1.0	2.0	2.0	2.0	4.0	3.0	5.0	8.0	3.0
	operating class 2	0.5	1.0	1.0	1.0	2.0	1.5	2.5	4.5	2.5

Operation in icy conditions

According to DIN EN 13659 it is imperative to point out when a product cannot be operated under icy conditions. This generally has to be assumed for roller shutters because extreme weather conditions may cause the unit to freeze. For the company mounting the units it is of legal importance to pass this warning on to the customer with the order confirmation at the latest to avoid any subsequent problems.

It is furthermore recommended to have written documentation of the handing over of the operating instructions to the end user due to therein contained notes which absolutely need to be observed.

Manufacturing tolerances

Perfection is in the detail. That is why we attach great importance even to small things: Every product is manufactured exactly to customer specifications. Please note that this custom manufacturing process can lead to small production-related deviations.

Manufacturing tolerances T in mm	Order width B in mm	T	Order height H/length L in mm	T
V4, V6, V10 and FR23, FR24	B ≤ 2000	±1.5	H ≤ 1500	±2
	2000 < B ≤ 4000	±2	1500 < H ≤ 2500	±3
	B > 4000	±2.5	H > 2500	±5

Requirements for external sun shading systems

Roller shutters

General information

All dimensions and details in the Technical data are in accordance with DIN EN 13659.

Important note:

External venetian blinds without options must not be mounted in the area of escape routes, as external venetian blinds can – e.g. in case of a power failure – not be retracted any more and would thus block escape routes. Local regulations on escape routes have to be observed.

Heat protection

The insulating effect is essentially based on the air space between window and roller shutter. The ideal insulating effect is achieved with a distance of 40 mm. Closing the roller shutter results in an almost static layer of air with this insulating effect. Insulation from the roller shutter itself is negligible due to the low material thickness.

Sound insulation

Sound insulation improves with increasing distance between window and roller shutter. The ideal distance is between 80 and 120 mm.

Influence of distance between roller shutter and window pane on heat protection and sound insulation

Resistance of thermal transition as a function of the distance (outer edge of window pane – inner edge of roller shutter)

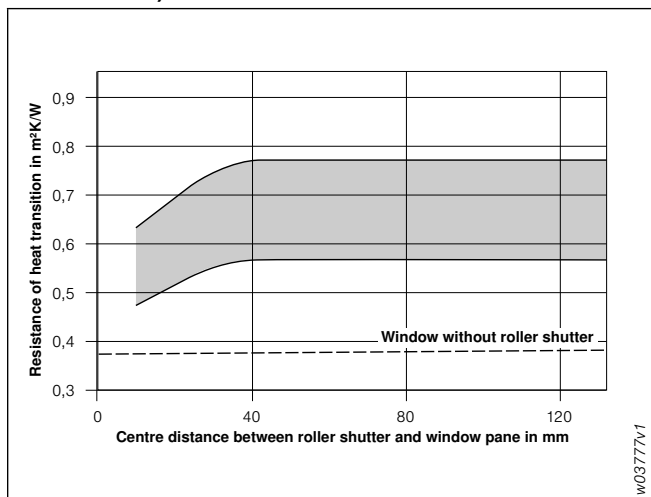

Fig. 1: Resistance of thermal transition as a function of the distance (outer edge of window pane – inner edge of roller shutter)

Sound absorbing coefficient as a function of the distance (outer edge of window pane – inner edge of roller shutter)

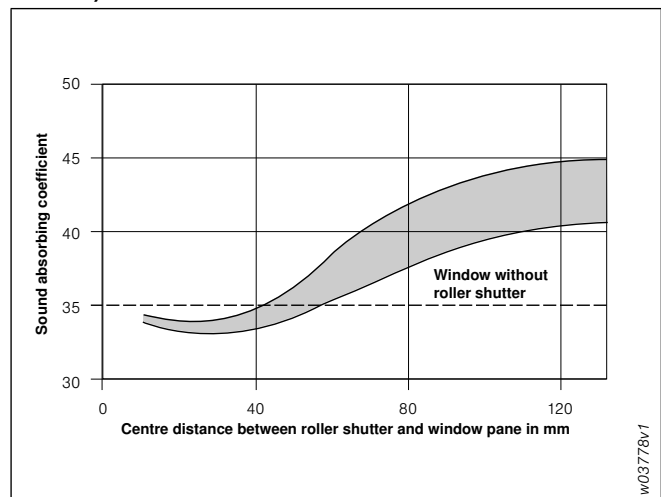

Fig. 2: Sound absorbing coefficient as a function of the distance (outer edge of window pane – inner edge of roller shutter)

Product identification

EC Declaration of Conformity



Name: WAREMA Renkhoff SE
Year of declaration of conformity: 2006
Head office: Hans-Wilhelm-Renkhoff-Strasse 2
 97828 Marktheidenfeld
 Germany
Standard: DIN EN 13659:2009-01 External closures – Requirements for performance and safety
Product: Roller shutters
Intended use: for outdoor installation
Wind class: in accordance with table "Max. order width for roller shutters for each wind resistance class in mm", see page 23
Noise emission level: <70 dB (A)¹⁾ overall

¹⁾ For standard mounting, the noise emission level is <70 dB (A). This value may vary depending on installation.

Requirements for external sun shading systems

External venetian blinds

Weather protection

Rough climatic conditions place significant demands on external sun shading systems. WAREMA external venetian blinds have been tested in a wind tunnel and proven their qualities in practice – even under the most extreme weather conditions.

DIN EN 13659

EC Declarations of Conformity are available for all WAREMA external sun shading systems. The products conform to DIN EN 13659 (external venetian blinds/external blinds/roller shutters) or DIN EN 13561 (awnings). These standards govern the requirements for external sun shading systems. All electrical drives used are certified in line with current applicable standards and carry the respective markings. Our external venetian blinds perform the function of a sun and anti-glare protection system. Due to the nature of the system, entry of daylight cannot be completely avoided when closed. If complete blackout of the room is required, additional dim-out measures must be taken.

This documentation is intended to explain our products and services and to provide advice on the best possible use in your specific environment. This does not release you from the obligation to examine this documentation thoroughly to satisfy yourself of the suitability of our products and services for your intended application. This primarily includes the examination of the general characteristics and specifically the adequate load bearing capacity of the mounting substructures, as well as the disclosure of all respective information in the order placed with us. If our product cannot be used as agreed by reason of incorrect or incomplete information, we or our vicarious agents shall accept contractual or non-contractual liability only in the event of intent or gross negligence.

Note

When ordering, please ensure that the selected fixing accessories are suitable for the respective mounting substructure, and that the processing instructions given by the fixing materials manufacturer are complied with.

Operation in icy conditions

Do not operate the external venetian blinds when iced over. The unit must first be freed from snow and ice before it can be operated. Liability cannot be accepted for damage to the sun shading system resulting from operation while iced over.

Recommendation: Use electronic control systems with an ice monitoring system. When using a control unit without ice monitoring, switch off automatic operation in winter and ensure that the unit is not iced up before manual operation.

Important information!

External venetian blinds without options must not be mounted in the area of escape routes, since external venetian blinds can – e.g. in case of a power failure – not be retracted any more and would thus block escape routes. Local regulations on escape routes have to be complied with.

Your external venetian blind/external blind is a sun shading system. To ensure proper utilisation, it must be retracted in time before any of the following conditions occur:

- Wind stronger than the recommended wind speed limit according to Table 6 on page 28
- Snowfall
- Thunderstorms and cold fronts (gusts)

Wind

WAREMA external venetian blinds meet the requirements of DIN EN 13659 and resist dynamic loads of max. 17.4 m/s (equivalent to wind force 7 on the Beaufort scale), depending on lateral guide, installation situation on site, type, dimensions and distance from the facade. See Table 6 on page 28.

After installation, the external venetian blinds will only meet the requirements of the specified wind speed limits provided that

- the recommended number of brackets, supports and guides have been mounted
- the dowel manufacturers' instructions have been observed for mounting

For mounting on wood, no wind speed limits can be specified due to the variance of this construction material.

DIN 1055

All WAREMA external venetian blinds designed for external use are designed for wind loads of 1.1 kN/m².

The guideline 'Wind loads for the construction of closures and awnings in the retracted position – item 5.1.1¹⁾' defines in which situations these products may be mounted without special precautions.

Manufacturing tolerances

Perfection is in the detail. That is why we attach great importance even to small things: Every product is manufactured exactly to customer specifications. Please note that this custom manufacturing process can lead to small production-related deviations.

Manufacturing tolerances T in mm	Order width B in mm	T	Order height H/length L in mm	T
Front-mounted external venetian blinds R6/R10	B ≤ 2000	±1.5	H ≤ 1500	±2
	2000 < B ≤ 4000	±2	1500 < H ≤ 2500	±3
	B > 4000	±2.5	H > 2500	±5

1) issued by the Bundesverband Rollladen + Sonnenschutz e.V. and Bundesverband Konfektion Technischer Textilien e.V. – BKTex

Requirements for external sun shading systems

External venetian blinds

Wind forces

The following Beaufort table contains the wind speeds allocated to Beaufort degrees and describes the effect of the wind.

Beaufort level	Designation	Medium wind speed at 10 m above ground in a free area		Backpressure (average value) q in N/m ²	Examples of the effects of inland wind
		m/s	km/h		
0	Calm	0–0,2	<1	0	Smoke rises vertically
1	Light air	0.3-1.4	1-5	0.6	Smoke drift indicates wind direction
2	Light breeze	1.5-3.4	6-12	6	Wind felt on exposed skin, leaves rustle, vanes begin to move
3	Gentle breeze Light wind	3.5-5.4	13-19	16	Leaves and small twigs constantly moving, light flags extended
4	Moderate breeze Moderate wind	5.5-7.4	20-27	30	Dust and loose paper raised, small branches begin to move
5	Fresh breeze Stiff wind	7.5-10.4	28-37	60	Small trees in leaf begin to sway, white horses begin to form on lakes
6	Strong breeze	10.5-13.4	38-48	110	Large branches in motion, whistling heard in overhead wires; umbrella use becomes difficult
7	High wind	13.5-17.4	49-62	160	Whole trees in motion. Effort needed to walk against the wind
8	Gale	17.5-20.4	63-73	230	Some twigs broken from trees, progress on foot is seriously impeded
9	Strong gale	20.5-24.4	74-87	330	Some branches break off trees, minor damage to buildings (roof tiles or smoke covers lifted off)
10	Storm	24.5-28.4	88-102	460	Wind breaks trees, extensive damage to buildings
11	Violent storm	28.5-32.4	103-117	600	Wind uproots trees, wide-spread storm damage
12	Hurricane-force	from 32.5	from 118	770	Serious devastation

Requirements for external sun shading systems

External venetian blinds

Product overview

External venetian blinds, beaded slats with rail guidance

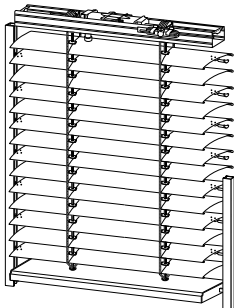

External venetian blinds, flat slats with rail guidance

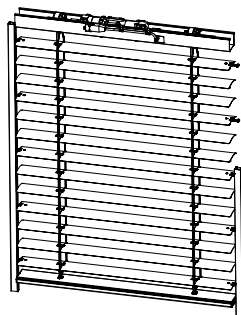

Technical data

For measurements and weights please refer to the respective construction limit values.

Parameter	Value
Rated torque	6 to 20 Nm
Revolutions	26 rpm
Rated voltage	230 V AC
Current consumption	0.42 to 0.85 A
Power consumption	90 to 190 W
Motor protection rating	IP 54
Short term operation (S2)	approx. 4 minutes

Tab. 5: Motor drive

Wind speed limits according to the Technical Directive Sheet 6.2, pages 1 and 2, of the German association "Roll-laden + Sonnenschutz e. V.".

Width in mm	Beaded slats with rail guidance		Flat slats with rail guidance	
	bft	m/s	bft	m/s
1500	7	13.5 – 17.4	7	13.5 – 17.4
2000	7	13.5 – 17.4	6	10.5 – 13.4
2500	7	13.5 – 17.4	6	10.5 – 13.4
3000	7	13.5 – 17.4	6	10.5 – 13.4
4000	6	10.5 – 13.4	5	7.5 – 10.4
5000	6	10.5 – 13.4	5	7.5 – 10.4

Tab. 6: Application recommendations for external venetian blinds. Slat width 50 to 150 mm (50, 100 and 150mm only flexible), standard design (wind speed limits of wind-stable external venetian blinds, see construction limit values for wind-stable external venetian blinds)

For external venetian blinds and external blinds, the recommended wind speed limits depend on the particular product type. When the wind speed limits are reached, the unit must be retracted. The values apply to a distance of the slats from the facade of ≤ 100 mm, for a material thickness of the slats of ≥ 0.4 mm and a system height of < 2400 mm.

Depending on the type, one or more additional cord guides may be required for larger widths.

The table values should be reduced in the following cases:

1. weatherproof and corrosion-resistant In case of a facade distance of > 100 mm up to 300 mm, the value given in the table must be reduced by one Beaufort; in case of a facade distance of > 300 up to 500 mm, by two Beaufort; beyond these values, the table is not applicable.
2. weatherproof and corrosion-resistant If the thickness of the slat material is less than 0.4 mm, the value given in the table must be reduced by one Beaufort.
3. In case of heights of 2400 mm to 4000 mm and cord guides, the value given in the table must be reduced by one Beaufort; in case of heights of more than 4000 mm, the value must be reduced by two Beaufort.

It is recommended to set wind monitors to the lowest setting, e.g. for Beaufort 7 to 13.5 m/s.

Product identification

EC Declaration of Conformity

CE Name: WAREMA Renkhoff SE
Year of declaration of conformity: 2006
Head office: Hans-Wilhelm-Renkhoff-Strasse 2
 97828 Marktheidenfeld
 Germany
Standard: DIN EN 13659:2009-01 External closures – Requirements for performance and safety
Product: External venetian blinds
Intended use: for outdoor installation
Wind class: 0¹⁾
Noise emission level: < 70 dB (A)²⁾

¹⁾ Wind class 0 stated, as the standard test benches are not applicable. For use of wind speed data and Beaufort scale, see table 3: "Application recommendations for external venetian blinds", as proposed in the Technical Directive.

²⁾ For standard mounting, the noise emission level is < 70 dB (A). This value may vary depending on installation.

Note on standards

External venetian blinds without options (e.g. emergency retraction) must not be mounted in the area of escape routes, since e.g. in case of a power failure external venetian blinds cannot be retracted and would thus block escape routes. Local regulations on escape routes have to be complied with.

Height-to-width ratio for external venetian blinds

The maximum and minimum dimensions given in the construction limit values are height-dependent.

Therefore, it has to be ensured that the height of the external venetian blinds does not exceed the size ratio of 1 to 4 for widths < 1 m.

That means: For a width of 800 mm the external venetian blind can be produced only up to a height of 3200 mm without limiting the functionality.

Type key/type matrix

Front-mounted roller shutters and external venetian blinds

Examples:





V6 A 36

	<p>A 36 = aluminium, double walled, foam filled A 44 = aluminium, double walled, foam filled A 53 = aluminium, double walled, foam filled S 37 = aluminium, double walled, extruded K 36 = plastic, double walled V 36 = plastic, reinforced</p>
--	---

- V4 = WAREMA front-mounted roller shutters, roll formed (insect screen optional)
- V6 = WAREMA front-mounted roller shutters, extruded (insect screen optional)
- V10 = WAREMA front-mounted roller shutters, extruded, with insect screen or solar drive
- FR 23/FR 24 = WAREMA security roller shutters
- R6 = WAREMA front-mounted external venetian blinds, extruded, solar drive optional
- R10 = WAREMA front-mounted external venetian blinds, extruded, solar drive and insect screen optional
- FR = prefabricated roller shutters
- V = front-mounted roller shutters
- R = front-mounted external venetian blinds

Type matrix

Box types





				
V4	●	●	●	●
V6	●	●	●	●
V10	●	●	●	●

Legend:
● standard
○ optional
- not possible

Using this matrix you can quickly read the find the features of the type ranges and box sizes and select options where possible. This matrix is provided with every feature, enabling you to quickly find the right roller shutter for you.

Overview of accessories/equipment

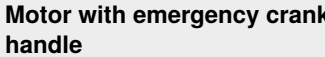
Front-mounted roller shutters/front-mounted external venetian blinds

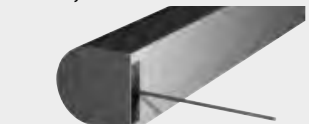
Accessories/equipment	Description	Front-mounted roller shutters/ front-mounted external venetian blinds				
		V4	V6	V10	FR 23/24	R6/10
Legend: ● standard ○ optional – not possible						
Construction limit values (for individual units)						
max. width (mm)	3000	●	●	●	●	●
	3500	–	●	●	–	●
	4000	–	–	–	–	●
	max. height (mm)					
2500	2500	●	●	●	●	●
	2750	●	●	●	–	●
	3000	●	●	●	–	●
	3250	●	●	●	–	●
	3500	–	●	●	–	●
	4000	–	–	–	–	●
	Box type/material					
Aluminium	folded	●	–	–	●	–
	extruded	–	●	●	–	●
Box sizes						
	12.5	●	●	–	–	–
	14.5	●	●	●	–	–
	16.5	●	●	●	–	●
	18.5	●	●	●	–	●
	20.5	–	●	●	–	–
	16	–	–	–	●	–
	18	–	–	–	●	–
	Box depth					
	standard box	●	●	–	●	●/–
	deep box	–	–	●	–	–/●
Operation						
 Motor	as a standard with torque overload protection for roller shutters or adjustable upper and lower limit switch-off for external venetian blinds.	●	●	●	●	●
	 Radio motor	EWFS radio motor with torque overload protection, EWFS hand-held transmitter 1 channel comprised. (EWFS: standardised WAREMA radio system)	○	○	○	–
 Motor with emergency crank handle	available from box size 16.5	○	○	–	–	–
 Solar drive		–	–	○	–	○
 Crank, internal	crank rod thermally separated, sealed joint plate	●	●	●	●	●







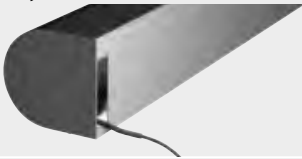

Overview of accessories/equipment

Front-mounted roller shutters/front-mounted external venetian blinds

Accessories/equipment	Description	Front-mounted roller shutters/ front-mounted external venetian blinds				
		V4	V6	V10	FR 23/24	R6/10
Legend: ● standard ○ optional – not possible						
Crank, with pull-out gear 	crank rod thermally separated, sealed joint plate	○	○	○	–	–
Coupling funnel for detachable Crank rod 		○	○	○	○	○
Belt, internal, with adjustable belt guiding roller 		○	●	●	–	–
Belt, internal, with fixed belt guiding roller 		●	–	–	–	–
Belt deflection type 6a 		○	○	○	–	–
Belt deflection type H 		○	○	○	–	–
Belt, with pull-out belt disc 		○	○	○	–	–
Crank winder for belt 		○	○	○	–	–





Overview of accessories/equipment

Front-mounted roller shutters/front-mounted external venetian blinds

Accessories/equipment	Description	Front-mounted roller shutters/ front-mounted external venetian blinds				
		V4	V6	V10	FR 23/24	R6/10
Legend: ● standard ○ optional – not possible						
Cord, internal 		○	○	○	–	–
Crank winder for cord 		○	○	○	–	–
EWFS/WMS plug receiver, EWFS/WMS actuator 	especially for front-mounted external venetian blinds, basically also suitable for roller shutters	○	○	○	○	○
Roller shutter curtain/profiles per type						
A 36 		○	○	○	–	–
A 44 		○	○	○	–	–
A 53 		○	○	–	–	–
S 37 		–	○	○	●	–
K 36 		○	○	○	–	–
V 36 		○	○	○	–	–

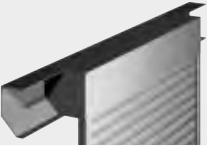
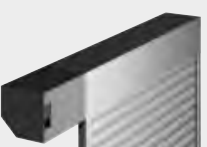





Overview of accessories/equipment

Front-mounted roller shutters/front-mounted external venetian blinds

Accessories/equipment	Description	Front-mounted roller shutters/ front-mounted external venetian blinds				
		V4	V6	V10	FR 23/24	R6/10
Legend: ● standard ○ optional – not possible						
External venetian blind slats 	80 mm slats, beaded (80 A6) and flat (80 AF A6), 73 mm dim out slat (73 A6)	–	–	–	–	●
Accessories						
Plaster elements	optional plaster elements, but standard with box shape Plaster	○	○	○	–	○
Box extension						
Type 3 	without side cover, open at the rear	–	○	○	–	–
Type 4 	with side cover, open at the rear	–	○	○	–	–
Type 5 	closed, drive in the extension	○	○	○	–	–
Type 6 	closed, drive not in the extension	○	○	○	–	–
Type 7 	continuous box	○	○	○	–	○
Mitre cuts 	on boxes closed on all 4 sides	–	○	○	–	○
Complete corner section (box extension type 8)	2x mitre cut + box extension	–	○	○	–	○
Clip-on cover	for concealing mitre cuts	–	○	○	–	○

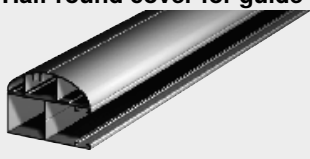
Overview of accessories/equipment

Front-mounted roller shutters/front-mounted external venetian blinds

Accessories/equipment	Description	Front-mounted roller shutters/ front-mounted external venetian blinds				
		V4	V6	V10	FR 23/24	R6/10
Legend: ● standard ○ optional – not possible						
Corner section	completely welded	–	○	○	–	○
Centre rail	for combinations	○	○	○	–	○
Quick installation kit 	for easier mounting of guide rails available for the following guide rails: 46–25, 46–35, 55–25, 55–35, 85–25, 85–35	○	○	–	–	–
Projection unit 	also in combination with insect screen roller blind	○	○	○	–	–
Security package 	meets special requirements for increased burglar resistance in accordance with DIN 18073 through: – reinforced push-up guard – Increased lateral curtain insertion length using wider guide rails (60 mm) – reinforced guide rails prevent bending from the outside – inspection cover and guide rails with increased protection against dismantling from outside – secured against prying the box out from outside – highly rigid end rails	–	○	○	–	–
Guide rails						
Half-round cover for guide rail 	available for all guide rails with a visible width of 55 mm	○	○	○	–	–
Minimax guide rail 	Guide rails with a small visible width of only 37 mm. also available in combination with an insect screen roller blind.	–	○	○	–	–
End rails						
Triangular design end rail 	provides an attractive end cover; for motor drive it provides almost flush closure. Alternatively with sealing strip.	●	●	●	–	–
Flat end rail 	in combination with insect screen, alternatively with sealing strip	●	●	○	–	–

Contents

Front-mounted roller shutters V4

Description	36
Construction limit values	39
Area diagram	41
Box dimensions	43

Description

Front-mounted roller shutters V4

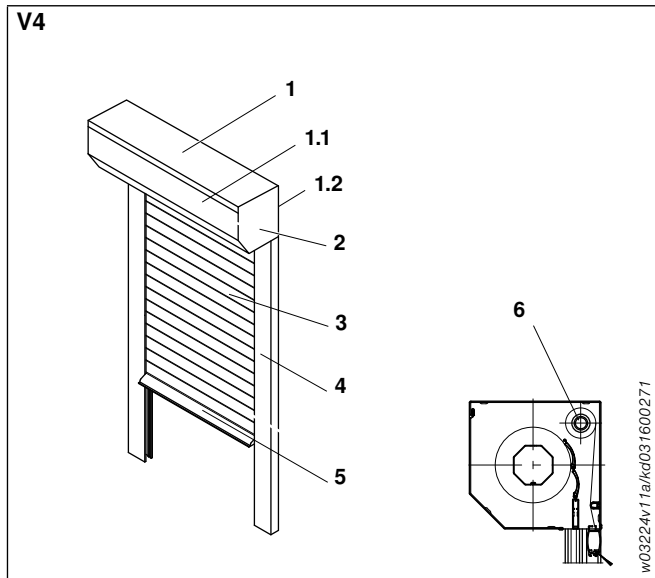

Fig. 3: Front-mounted roller shutters V4

1 Box

1.1 Inspection cover

1.2 Side cover

2 Shaft

3 Roller shutter curtain

4 Lateral guidance

5 End rail

6 Insect screen roller blind (optional)

6.1 Drive via spring-loaded shaft

6.2 Insect screen gauze

6.3 Handle rail

6.4 Insect screen retrofitting set

Application

Can be used for retrofitting as well as for new buildings and renovations.

Operation

Motor

with torque overload protection in upper or lower limit position; without operating switch

Voltage: 230 V AC

Frequency: 50 Hz

Protection class: IP 44

Motor cable (l): 1000 mm, optionally 2500 mm, 5000 mm or 10000 mm

EWFS radio motor (optional)

with torque overload protection, EWFS hand-held transmitter 1 channel comprised

Motor with emergency crank handle (optional)

from box size 16.5 available in combination with flat end rail

Crank

Crank rod with collapsible crank; sealed joint plate and square with thermal separation

Material: aluminium

Surface: C0 anodised, optionally powder-coated in RAL 9016 or anodised C34

Crank holder: plastic, grey, white or brown, crank holder with magnet optional

Belt

Dimensions (w): 14 mm (23 mm only for box shape plaster in combination with a box extension)

Colour: belt winder/brush guiding roller white, brown optional
belt grey, brown optional

Optional with step-up-gear for belt.

Cord (optional)

with cord deflection roller and feedthrough device

Dimensions (Ø): 4.5 mm

Colour: cord winder white, brown optional
cord black and white, brown optional

Detailed description of types of drive and operation modes from page 84.

Box (1)

4 box sizes, closed on 4 sides (box shape rectangular, Round, Square) or on 3 sides (box shape plaster)

Box shapes: rectangular, round, square, plaster

Material: aluminium, roll-formed/folded

Dimensions: see table on page 37

Surface: coated with coil coating process, with protective film or plain for box shape plaster

Box available as left-rolling blind.

Maximum box width for box shape rectangular, round, square 3000 mm.

Maximum box width for box shape plaster 4000 mm.

Optional plaster elements 12 mm to 15 mm (plaster elements are a standard with box shape plaster).

Concealed cut edges on the covers.

Inspection cover (1.1)

Material: aluminium, roll formed/folded or

extruded for box shape plaster coated with coil coating process, with protective film or powder-coated for box shape Plaster

Surface:

Side covers (1.2)

Material: diecast aluminium

Surface: powder-coated

Description

Front-mounted roller shutters V4

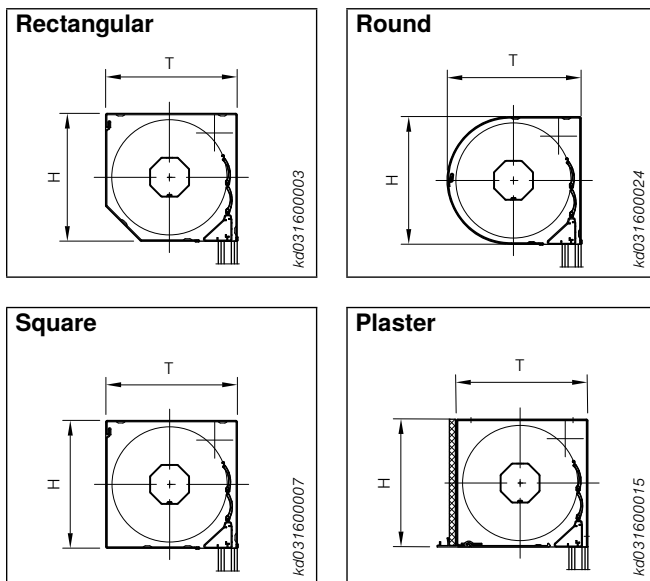

Fig. 4: Box V4

Box dimensions in mm

Box size	Height H	Depth D (R; S; P)	Depth D (R)
12.5	129	134	-
14.5	149	154	157
16.5	169	174	177
18.5	189	194	197

Please note: Box shape Round only available from box size 14.5!

Shaft (2)

Material: steel, zinc-coated
 Material thickness: 0.8 mm
 Dimensions (WAF): 52 mm
 Profile: octagonal
 Surface: plain

Roller shutter curtain (3)

with light slots

A 36, A 44, A 53

Material: aluminium, double walled, foam filled
 Surface: enamelled

K 36

Material: plastic, double walled
 Surface: plastic

V 36

Material: plastic roller shutter curtain (K 36), every 5th profile is made of aluminium (A 36)

Surface: plastic/aluminium enamel finish
 Fixing: with pressure springs on the shaft
 Automatic push-up guard through locking device using pressure springs.

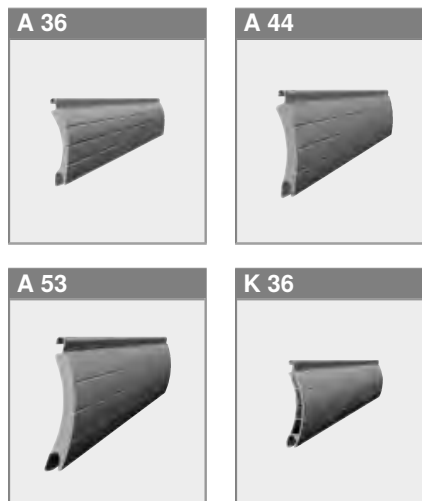

Lateral guidance (4)

Guide rails

Material: aluminium, extruded
 Dimensions: see details on page 109.
 Fixing: stepped drilled hole in the guide rail
 Surface: powder-coated
 Sealing strip: plastic, black, optional brush sealing strip

Plastic cover plug comprised (colour adapted to colour of the guide rails).

When using guide rail 55-47 (available for profile A 36, K 36, V 36) please note the information on ordering heights on page 40.

End rail (5)

Triangular design end rail, without sealing strip

Material: aluminium, extruded
 Surface: powder-coated

Triangular design end rail for an attractive closure for belt and crank. On motor operated units it provides almost flush closure.

Flat end rail optional or as a standard for models with insect screen roller blind/swivel frame.

End rails without or optionally with sealing strip.

Guide rail 55-47 only with flat end rail.

Insect screen roller blind (6) (optional)

(available from box size 16.5)

Drive via spring-loaded shaft (6.1)

Locking device in the lower section through end cap with catch mechanism. Soft raise function.

Insect screen gauze (6.2)

extremely tear resistant, weatherproof and resistant to corrosion

Material: fibre glass fabric

Coating: plastic

Colour: grey, optionally black (for technical reasons the transparent gauze is not available for the insect screen roller blind)

Description

Front-mounted roller shutters V4

Handle rail (6.3)

Operation:	by using the integrated full-width profile
Material:	aluminium, extruded
Dimensions:	41 x 18 mm
Surface:	powder-coated
Sealing strip:	brush sealing strip sealing towards the window, alternatively downwards (to the window sill)

The hand rail is additionally furnished with a cord tassel, length 85 mm. The handle rail can be optionally fitted a plastic handle shell (available colours: grey, white, black). Fixed for operation alternatively inside, outside or on both sides, for details see page 75.

Retrofitting set (6.4)

Contains insect screen gauze (on the shaft), bottom handle rail and drive, 2 guide rails FSCH 29-25 and all required brush strips comprised. Ready-made for easy mounting in existing roller shutters.

Insect screen swivel frame (optional)

Especially for large openings, ideal for frequently used balcony and patio doors.

Operation:	with handle rail and integrated closing unit
Surface:	frame powder-coated
Colour:	aluminium parts in colour of box gauze grey, optionally black transparent gauze (without surcharge)

Insect screen with fixed frame optionally available.

Gauze for swivel or fixed frames optionally as pollen screen or stainless steel gauze.

Guide rail 55-47 allows the use of insect screen roller blinds or swivel frames as well as fixed frames. When box depths are the same available when ordering or for retrofitting within the ordering heights on the next page.

Note: The integrated solutions provide increased protection against insects. We recommend using a box closed on 4 sides.

Please note the details about insect screen roller blinds and swivel frames on page 74 pp.

Colours

Box coated with coil coating process, guide and end rails powder-coated, available in four standard colours:

RAL 9016 traffic white

RAL 7035 light grey

RAL 9006 white aluminium

RAL 8014 sepia brown

Roller shutter curtain according to WAREMA colour chart for roller shutter profiles.

Minor colour variations on individual components may occur due to different manufacturing processes.

Accessories

Projecting arm (guide rails with projection arm): The guide rails can be projected together with the lowered roller shutter curtain using the manually operated projection arm. Also available in combination with an insect screen roller blind (minimum height for roller shutter 1100 mm), for details see page 71.

Quick installation kit

for easy and quick installation. Drilling screws and cover caps are integrated into the guide rails. Details see page 96.

Construction limit values

Front-mounted roller shutters V4

You can also use our free planning program at www.sonnenschutzplaner.de for planning the sun shading systems – configure the product and generate a technical drawing that can be integrated into your plans.

More installation examples for different wall structures for use in consultations can be found in our roller shutter application brochure, art. No. 213901.

Roller shutter curtain		Limit values			Operation modes and max. areas in m ²											
		max. width in mm	max. height in mm	max. area for individual unit in m ²	Cord	Belt, internal	Belt with pull-out belt disc	Belt deflection	Step-up gear for belt (from box size 14.5)	Crank winder for belt	Crank type 1, internal	Crank type 2, internal	Crank with pull-out gear	Motor with torque overload protection	EWFS radio motor	Motor with emergency crank handle (from box size 16.5)
Front-mounted roller shutters V4																
A 36	design-related	3000	3250	7.0	2.0	4.0	3.0	3.0	8.0	6.0	5.0	8.0	3.0	15.0	13.0	23.0
	DIN EN 13659 cl. 1				1.0	2.0	2.0	2.0	4.0	3.0	5.0	8.0	3.0			
	DIN EN 13659 cl. 2				0.5	1.0	1.0	1.0	2.0	1.5	3.0	5.5	3.0			
A 44	design-related	3000	2350	7.0	1.5	4.0	3.0	3.0	7.0	6.0	5.0	8.0	3.0	13.0	11.5	21.0
	DIN EN 13659 cl. 1				1.0	2.0	2.0	2.0	4.0	3.0	5.0	8.0	3.0			
	DIN EN 13659 cl. 2				0.5	1.0	1.0	1.0	2.0	1.5	2.5	4.5	2.5			
A 53	design-related	3000	2000	6.0	1.5	3.0	2.0	2.0	6.0	5.0	4.0	7.0	2.0	10.0	9.0	20.0
	DIN EN 13659 cl. 1				1.0	2.0	2.0	2.0	4.0	3.0	4.0	7.0	2.0			
	DIN EN 13659 cl. 2				0.5	1.0	1.0	1.0	2.0	1.5	2.5	4.5	2.0			
K 36	design-related	2000	3000	3.2	1.5	4.0	3.2	3.2	7.0	6.0	5.0	8.0	3.2	13.0	11.5	21.0
	DIN EN 13659 cl. 1				1.0	2.0	2.0	2.0	4.0	3.0	5.0	8.0	3.0			
	DIN EN 13659 cl. 2				0.5	1.0	1.0	1.0	2.0	1.5	2.5	4.5	2.5			
V 36	design-related	2200	3000	4.0	1.5	4.0	3.0	3.0	7.0	6.0	5.0	8.0	3.0	13.0	11.5	21.0
	DIN EN 13659 cl. 1				1.0	2.0	2.0	2.0	4.0	3.0	5.0	8.0	3.0			
	DIN EN 13659 cl. 2				0.5	1.0	1.0	1.0	2.0	1.5	2.5	4.5	2.5			
Insect screen roller blind		2000	2250	4.5												
Insect screen swivel frame ¹⁾		1300	2700	2.7												
Min. order width in mm					500	500	500	500	500	500	500	500	500	640	660	790
Min. order width with insect screen roller blind in mm (with soft raise function)					760	760	760	760	760	760	760	760	760	760	760	790
Min. order width with insect screen roller blind in mm (without soft raise function)					570	570	570	570	570	570	570	570	570	640	660	790

¹⁾ Insect screen swivel frame with one wing; for two wings the maximum widths and areas are doubled

Please note the relevant area diagram when determining the maximum areas.

Notes:

- For coupled units (max. 3 curtains) please add 10% of the roller shutter area per coupling to compensate for friction!
- From order widths of over 1500 mm we recommend additional box fastening. Details see page 97.

Construction limit values

Front-mounted roller shutters V4

Max. ordering heights per box size in mm

Box size	Roller shutter profile				
	A 36	A 44	A 53	K 36	V 36
12.5	1400 (-)	650	550	1400 (-)	1400 (-)
14.5	1900 (1600)	1100	900	1900 (1600)	1900 (1600)
16.5	2750	1700	1300	2650	2650
16.5 insect screen	1550	-	-	1550	1550
18.5	3250	2350	2000	3000	3000
18.5 insect screen	2250	-	-	2250	2250

Notes:

- Values in brackets relate to guide rail size 55-47 (not available for box size 12.5).
- Insect screen roller blind only available from box size 16.5.

Area diagram

Front-mounted roller shutters V4

Maximum dimensions for individual areas V4 with plastic roller shutter curtain in mm

Height	max. width with guide rail size 46 for profile V 36							max. width with guide rail size 46 for profile K 36						
	900	1000	1100	1200	1300	1400	1500	1600	1700	1800	1900	2000	2100	2200
1000								Insect screen roller blind (optional)						V 36
1100											K 36			
1200														
1300														
1400														
1500														
1600														
1700														
1800														
1900														
2000														
2100														
2200														
2300	Insect screen roller blind (optional) (max. height 2250 mm)													
2400														
2500														
2600														
2700														
2800														
2900														
3000		K 36	V 36											

The wind resistance class for each roller shutter profile can be found in the general information section on page 22ff.

Area diagram

Front-mounted roller shutters V4

Maximum dimensions for individual areas V4 with aluminium roller shutter curtain in mm

max. width with guide rail 46 for profile A 36

Height	Width																						
	900	1000	1100	1200	1300	1400	1500	1600	1700	1800	1900	2000	2100	2200	2300	2400	2500	2600	2700	2800	2900	3000	
1000																							
1100																							
1200																							
1300																							
1400																							
1500																							
1600																							
1700																							
1800																							
1900																							
2000	A 53																						
2100																							
2200																							
2300																							
2400	A 44																						
2500																							
2600																							
2700																							
2800																							
2900																							
3000																							
3100																							
3200																							
3300	A 36																						

The wind resistance class for each roller shutter profile can be found in the general information section on page 22ff.

Box dimensions

Front-mounted roller shutters V4

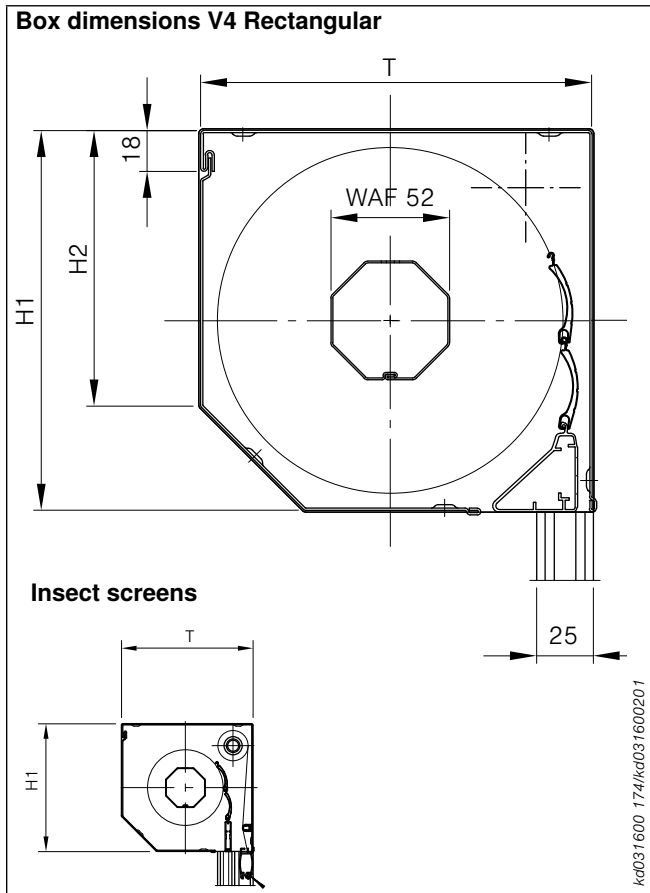

Fig. 5: Box dimensions V4 rectangular

Box size	Dimensions in mm		
	H1	H2	T
12.5	129	92	134
14.5	149	108	154
16.5	169	123	174
18.5	189	137	194

Notes:

- Box closed on 4 sides, max. width 3000 mm
- Mitre cuts not possible
- An additional box closure is optionally available when using guide rail 55-47 without insect screen (details on page 98).

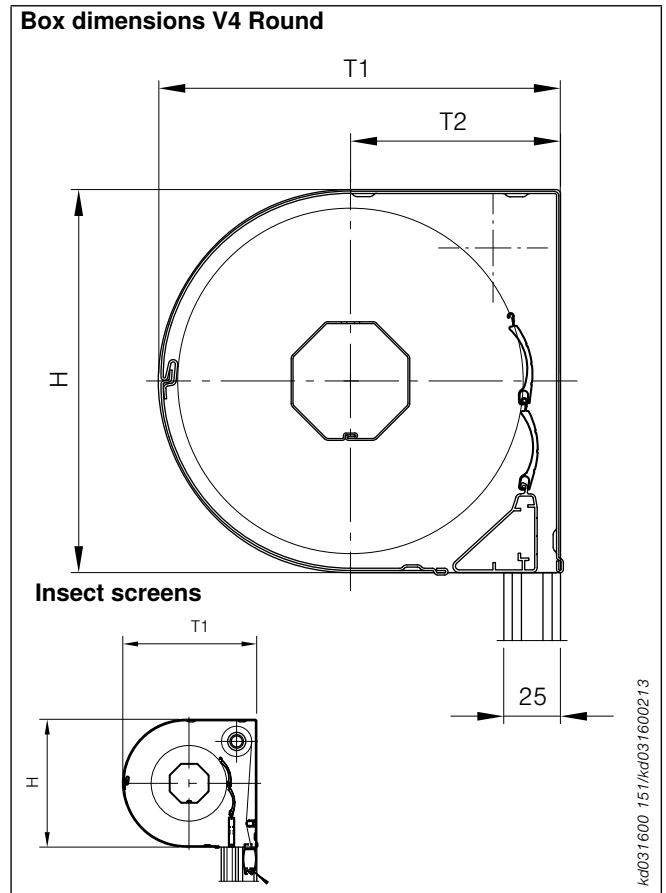

Fig. 6: Box dimensions V4 round

Box size	Dimensions in mm		
	H	T1	T2
14.5	149	157	80
16.5	169	177	90
18.5	189	197	100

Please note: Box shape Round only available from box size 14.5.

Notes:

- As for V4 rectangular

Box dimensions

Front-mounted roller shutters V4

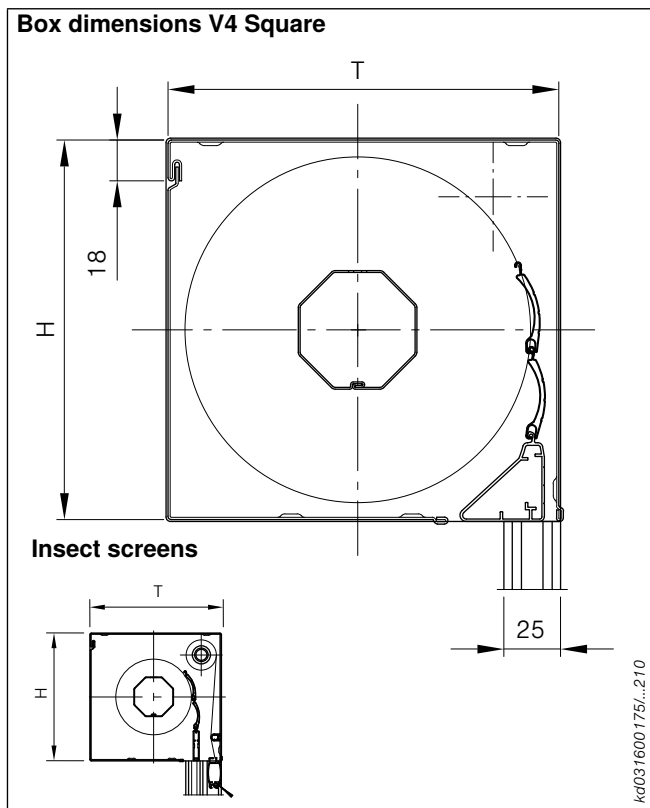

Fig. 7: Box dimensions V4 square

Box size	Dimensions in mm	
	H	T
12.5	129	134
14.5	149	154
16.5	169	174
18.5	189	194

Notes:

- As for V4 Rectangular

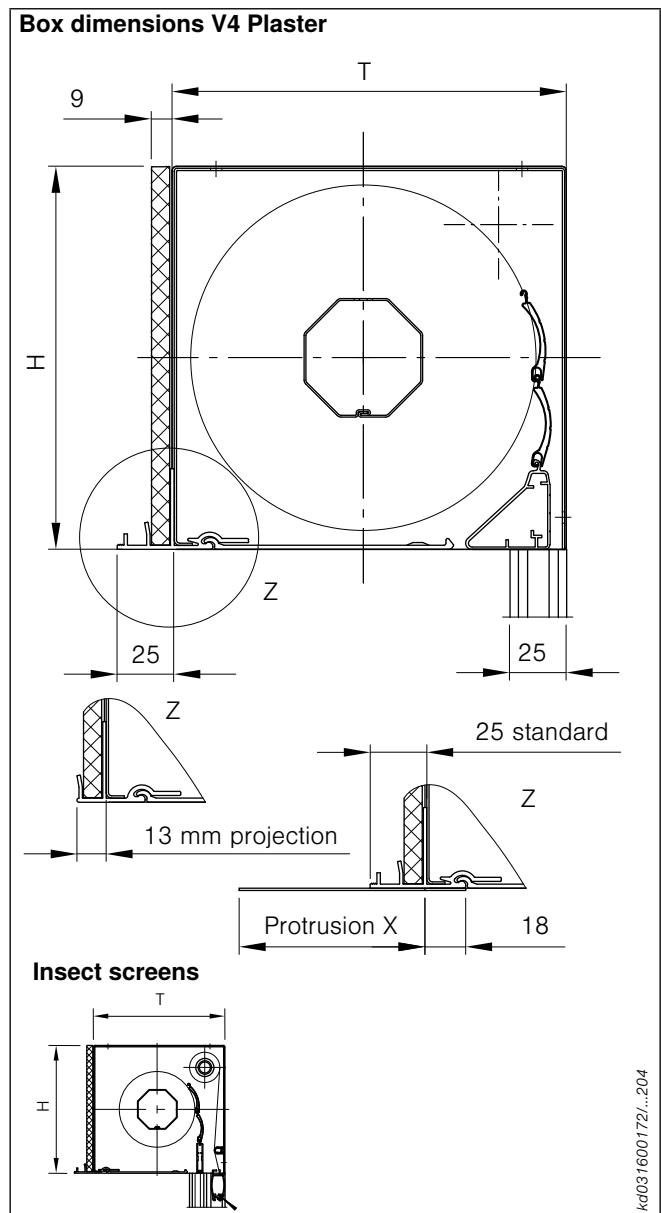

Fig. 8: Box dimensions V4 plaster

For dimensions H and D for each box size see table V4 Square (below Fig. 7).

Notes:

- Box closed on 3 sides as a standard, max. width 3000 mm
- Box optionally closed on 4 sides, max. width 4000 mm
- Box plain, inspection cover, plaster profile and plaster elements in same colour as powder-coated aluminium parts
- for a composite thermal insulation system the distance of the plaster base profile should be set to 13 mm (see Fig. 8). Please indicate on the order.
- The extended plaster base profile is used as a visual closure, it is not suitable for bearing loads from the insulation.

Contents

Front-mounted roller shutters V6

Description	46
Construction limit values	49
Area diagram	51
Box dimensions	52

Description

Front-mounted roller shutters V6

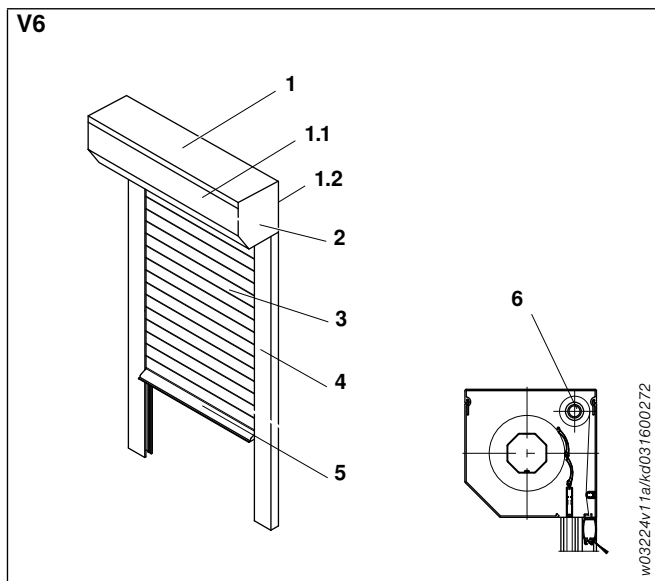

Fig. 9: Front-mounted roller shutters V6

1 Box

1.1 Inspection cover

1.2 Side cover

2 Shaft

3 Roller shutter curtain

4 Lateral guidance

5 End rail

6 Insect screen roller blind (optional)

6.1 Drive via spring-loaded shaft

6.2 Insect screen gauze

6.3 Handle rail

6.4 Insect screen retrofitting set

Application

Can be used for retrofitting as well as for new buildings and renovations.

Operation

Motor

with torque overload protection in upper or lower limit position; without operating switch

Voltage: 230 V AC

Frequency: 50 Hz

Protection class: IP 44

Motor cable (l): 1000 mm, optionally 2500 mm, 5000 mm or 10000 mm

EWFS radio motor (optional)

with torque overload protection, EWFS hand-held transmitter 1 channel comprised

Motor with emergency crank handle (optional)

from box size 16.5 available in combination with flat end rail

Crank

Crank rod with collapsible crank; sealed joint plate and square with thermal separation

Material: aluminium

Surface: C0 anodised, optionally powder-coated in RAL 9016 or anodised C34

Crank holder: plastic, grey, white or brown, crank holder with magnet optional

Belt

Dimensions (w): 14 mm (23 mm only for box shape plaster in combination with a box extension)

Colour: belt winder/brush guiding roller white, brown optional
belt grey, brown optional

Optional with step-up-gear for belt.

Cord

with cord deflection roller and feedthrough device

Dimensions (Ø): 4.5 mm

Colour: cord winder white, brown optional
cord black and white, brown optional

Detailed description of types of drive and operation modes from page 84.

Box (1)

5 box sizes, closed on 3 sides (optionally on 4 sides)

Box shapes: rectangular, round, square, plaster

Material: aluminium, extruded

Dimensions: see table on page 47

Surface: powder-coated, anodising optional

Box available as left and right rolling blind (right rolling blind only as model closed on 4 sides).

Maximum box width with box closed on 3 sides is 3000 mm, for box closed on 4 sides 6000 mm.

Optional plaster elements 12 mm to 15 mm (plaster elements are a standard with box shape Plaster).

Concealed cut edges on the covers.

Inspection cover (1.1)

Material: aluminium, extruded

Surface: powder-coated, anodising optional

Side covers (1.2)

Material: diecast aluminium

Surface: powder-coated, anodising optional

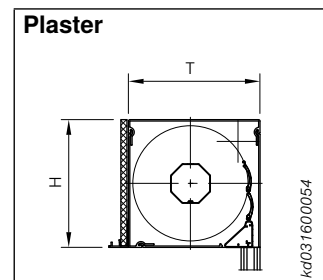
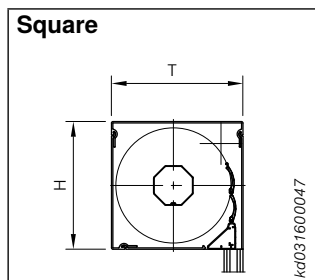
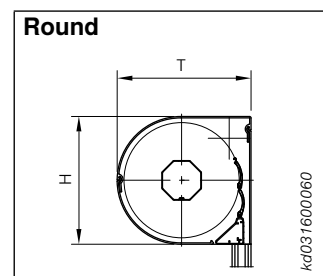
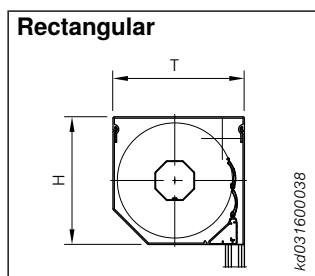

Fig. 10: Box V6

Description

Front-mounted roller shutters V6

Box dimensions in mm

Box size	Height H	Depth D (R; S; P)	Depth D (R)
12.5	129	134	–
14.5	149	154	157
16.5	169	174	177
18.5	189	194	197
20.5 ¹⁾	209	214 ¹⁾	217

¹⁾ Only for box shapes rectangular and round.

Please note: Box shape round only available from box size 14.5!

Shaft (2)

Material: steel, zinc-coated
 Material thickness: 0.8 mm
 Dimensions (WAF): 52 mm
 Profile: octagonal
 Surface: plain

Roller shutter curtain (3)

with light slots

A 36, A 44, A 53

Material: aluminium, double walled, foam filled
 Surface: enamelled

K 36

Material: plastic, double walled
 Surface: plastic

S 37

Material: aluminium, double walled, extruded
 Surface: powder-coated

V 36

Material: plastic roller shutter curtain (K 36), every 5th profile is made of aluminium (A 36)

Surface: plastic/aluminium enamel finish
 Fixing: with pressure springs on the shaft (not for S 37)

Automatic push-up guard through pressure spring locking (not for S 37).

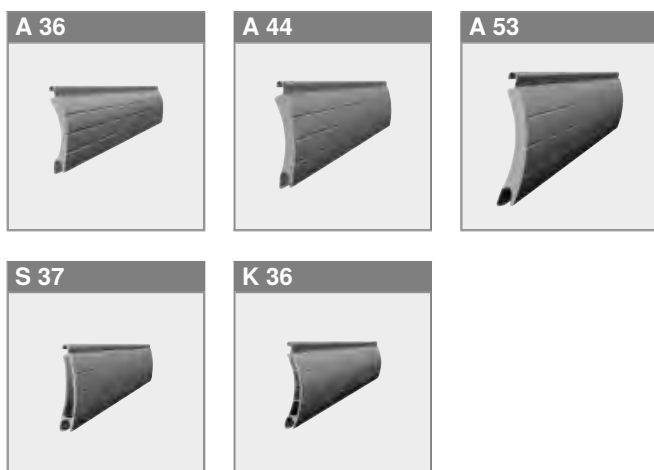

Lateral guidance (4)

Guide rails

Material: aluminium, extruded
 Dimensions: see details on page 109.
 Fixing: stepped drilled hole in the guide rail
 Surface: powder-coated, anodising optional
 Sealing strip: plastic, black, optional brush sealing strip

Plastic cover plug comprised (colour adapted to colour of the guide rails).

When using guide rail 55-47 (available for profile A 36, K 36, V 36) please note the information on ordering heights on page 50.

Optionally Minimax guide rails with small visible width available.

End rail (5)

Triangular design end rail, without sealing strip
 Material: aluminium, extruded
 Surface: powder-coated, anodising optional
 Triangular design end rail for an attractive closure for belt and crank. On motor operated units it provides almost flush closure.

Flat end rail optional or as a standard for models with insect screen roller blind/swivel frame.

End rail without or optionally with sealing strip.

Guide rail 55-47 only with flat end rail.

Insect screen roller blind (6) (optional)

(available from box size 16.5)

Drive via spring-loaded shaft (6.1)

Locking device in the lower section through end cap with catch mechanism. Soft raise function.

Insect screen gauze (6.2)

extremely tear resistant, weatherproof and resistant to corrosion

Material: fibre glass fabric
 Coating: plastic
 Colour: grey, optionally black (for technical reasons the transparent gauze is not available for the insect screen roller blind)

Handle rail (6.3)

Operation: by using the integrated full-width profile
 Material: aluminium, extruded
 Dimensions: 41 x 18 mm
 Surface: powder-coated
 Sealing strip: brush sealing strip sealing towards the window, alternatively downwards (to the window sill)

The hand rail is additionally furnished with a cord tassel, length 85 mm.

The handle rail can be optionally fitted a plastic handle shell (available colours: grey, white, black). Fixed for operation alternatively inside, outside or on both sides, for details see page 75.

Description

Front-mounted roller shutters V6

Retrofitting set (6.4)

Contains insect screen gauze (on the shaft), bottom handle rail and drive, 2 guide rails FSCH 29-25 and all required brush strips comprised. Ready-made for easy mounting in existing roller shutters.

Insect screen swivel frame (optional)

Especially for large openings, ideal for frequently used balcony and patio doors.

Operation: with handle rail and integrated closing unit

Surface: frame powder-coated

Colour: aluminium parts in colour of box
gauze grey, optionally black transparent gauze (without surcharge)

Insect screen with fixed frame optionally available.

Gauze for swivel or fixed frames optionally as pollen screen or stainless steel gauze.

Guide rail 55-47 allows the use of insect screen roller blinds or swivel frames as well as fixed frames. When box depths are the same available when ordering or for retrofitting within the ordering heights on the next page.

Note: The integrated solutions provide increased protection against insects. We recommend using a box closed on 4 sides.

Please note the details about insect screen roller blinds and swivel frames on page 74 pp.

Colours

Powder coating of aluminium parts (except roller shutter curtains) with chrome-free pre-treatment in accordance with valid RAL CLASSIC colour chart (except camouflage and luminous colours) or in DB colours 701, 702 and 703, as well as eight textured colours (W4914 - W4921), four anodised-look colours (WC31 - WC34), and further colours according to WAREMA standard colour chart (in WAREMA colour specification). Alternatively also C0 anodised in natural colour.

Other colour specifications, special colours or colour anodising are available upon request and at a surcharge.

Roller shutter curtain according to WAREMA colour chart for roller shutter profiles.

Accessories

Minimax guide rails with small visible width. also available with insect screen Details see page 94.

Projecting arm (guide rails with projection arm): The guide rails can be projected together with the lowered roller shutter curtain using the manually operated projection arm. Also available In combination with an insect screen roller blind (minimum height for roller shutter 1100 mm), for details see page 71.

Quick installation kit for easy and quick installation. Drilling screws and cover caps are integrated into the guide rails. For details see page 96.

Security package for advanced security requirements in accordance with DIN 18073:

Includes: reinforced push-up guard, inspection cover and guide rails with advanced protection against dismantling, protection against prying out the box, highly rigid triangular design end rail or flat end rail with locking device with sliding bolt, reinforced guide rails, roller shutter curtains within the maximum box width for wind resistance class 6. Details see page 95.

Locking device integrated into flat end rail, alternatively with

- espagnolette lock, lockable from inside and outside (only available for models without insect screen roller blind; lock must be accessible).
- Sliding bolt (operated from inside). Details see page 120.

Construction limit values

Front-mounted roller shutters V6

You can also use our free planning program at www.sonnenschutzplaner.de for planning the sun shading systems – configure the product and generate a technical drawing that can be integrated into your plans.

More installation examples for different wall structures for use in consultations can be found in our roller shutter application brochure, art. No. 213901.

Roller shutter curtain		Limit values			Operation modes and max. areas in m ²											
		max. width in mm	max. height in mm	max. area for individual unit in m ²	Cord	Belt, internal	Belt with pull-out belt disc	Belt deflection	Step-up gear for belt (from box size 14.5)	Crank winder for belt	Crank type 1, internal	Crank type 2, internal	Crank with pull-out gear	Motor with torque overload protection	EWFS radio motor	Motor with emergency crank handle (from box size 16.5)
Front-mounted roller shutters V6																
A 36	design-related				2.0	4.0	3.0	3.0	8.0	6.0	5.0	8.0	3.0			
	DIN EN 13659 cl. 1	3000	3500	7.0	1.0	2.0	2.0	2.0	4.0	3.0	5.0	8.0	3.0	15.0	13.0	23.0
	DIN EN 13659 cl. 2				0.5	1.0	1.0	1.0	2.0	1.5	3.0	5.5	3.0			
A 44	design-related				1.5	4.0	3.0	3.0	7.0	6.0	5.0	8.0	3.0			
	DIN EN 13659 cl. 1	3500	2900	9.0	1.0	2.0	2.0	2.0	4.0	3.0	5.0	8.0	3.0	13.0	11.5	21.0
	DIN EN 13659 cl. 2				0.5	1.0	1.0	1.0	2.0	1.5	2.5	4.5	2.5			
A 53	design-related				1.5	3.0	2.0	2.0	6.0	5.0	4.0	7.0	2.0			
	DIN EN 13659 cl. 1	3500	2600	10.0	1.0	2.0	2.0	2.0	4.0	3.0	4.0	7.0	2.0	10.0	9.0	20.0
	DIN EN 13659 cl. 2				0.5	1.0	1.0	1.0	2.0	1.5	2.5	4.5	2.0			
S 37	design-related				-	-	-	-	-	-	-	3.5	-			
	DIN EN 13659 cl. 1	3000	2800	7.0	-	-	-	-	-	-	-	3.5	-	7.0	4.5	7.0
	DIN EN 13659 cl. 2				-	-	-	-	-	-	-	-	-			
K 36	design-related				1.5	4.0	3.2	3.2	7.0	6.0	5.0	8.0	3.2			
	DIN EN 13659 cl. 1	2000	3000	3.2	1.0	2.0	2.0	2.0	4.0	3.2	5.0	8.0	3.2	13.0	11.5	21.0
	DIN EN 13659 cl. 2				0.5	1.0	1.0	1.0	2.0	1.5	2.5	4.5	2.5			
V 36	design-related				1.5	4.0	3.0	3.0	7.0	6.0	5.0	8.0	3.0			
	DIN EN 13659 cl. 1	2200	3000	4.0	1.0	2.0	2.0	2.0	4.0	3.0	5.0	8.0	3.0	13.0	11.5	21.0
	DIN EN 13659 cl. 2				0.5	1.0	1.0	1.0	2.0	1.5	2.5	4.5	2.5			
Insect screen roller blind		2000	2400	4.8												
Insect screen swivel frame ¹⁾		1300	2700	2.7												
Min. order width in mm					500	500	500	500	500	500	500	500	500	640	660	790
Min. order width with insect screen roller blind in mm (with soft raise function)					760	760	760	760	760	760	760	760	760	760	760	790
Min. order width with insect screen roller blind in mm (without soft raise function)					570	570	570	570	570	570	570	570	570	640	660	790

¹⁾ Insect screen swivel frame with one wing; for two wings the maximum widths and areas are doubled

Please note the relevant area diagram when determining the maximum areas.

Notes:

- For coupled units (max. 3 curtains) please add 10% of the roller shutter area per coupling to compensate for friction!
- For roller shutters with profile S 37 coupling and continuous cover panels are not available.
- From order widths of over 1500 mm we recommend additional box fastening. Details on page 97.

Construction limit values

Front-mounted roller shutters V6

Max. ordering heights per box size in mm

Box size	Roller shutter profile					
	A 36	A 44	A 53	S 37	K 36	V 36
12.5	1400 (-)	650	550	1100	1400 (-)	1400 (-)
14.5	1900 (1600)	1100	900	1700	1900 (1600)	1900 (1600)
16.5	2750	1700	1300	2400	2650	2650
16.5 insect screen	1550	-	-	-	1550	1550
18.5	3250	2350	2000	2800	3000	3000
18.5 insect screen	2250	-	-	-	2250	2250
20.5	3500	2900	2600	2800	3000	3000
20.5 insect screen	2400	-	-	-	2400	2400

Notes:

- Values in brackets relate to guide rail size 55-47 (not available for box size 12.5).
- Insect screen roller blind only available from box size 16.5
- Box sizes 12.5 and 20.5 are not available in combination with Minimax guide rails.

Area diagram

Front-mounted roller shutters V6

Maximum dimensions for individual areas V6 with plastic roller shutter curtain in mm

max. width with guide rail size 46 for profile V 36

max. width with guide rail size 46 for profile K 36

Height	max. width with guide rail size 46 for profile V 36								max. width with guide rail size 46 for profile K 36					
	900	1000	1100	1200	1300	1400	1500	1600	1700	1800	1900	2000	2100	2200
1000														
1100														
1200														
1300														
1400														
1500														
1600														
1700														
1800														
1900														
2000														
2100														
2200														
2300														
2400														
2500														
2600														
2700														
2800														
2900														
3000														

Insect screen roller blind (optional) K 36

Insect screen roller blind (optional) V 36

K 36 V 36

Maximum dimensions for individual areas V6 with aluminium roller shutter curtain in mm

max. width with guide rail 46 for profile A 36

Height	max. width with guide rail 46 for profile A 36																											
	900	1000	1100	1200	1300	1400	1500	1600	1700	1800	1900	2000	2100	2200	2300	2400	2500	2600	2700	2800	2900	3000	3100	3200	3300	3400	3500	
1000																												
1100																												
1200																												
1300																												
1400																												
1500																												
1600																												
1700																												
1800																												
1900																												
2000																												
2100																												
2200																												
2300																												
2400																												
2500																												
2600																												
2700																												
2800																												
2900																												
3000																												
3100																												
3200																												
3300																												
3400																												
3500																												

Insect screen roller blind (optional)

A 53

S 37

A 44

A 36

A 36, S 37

A 53, A 44

The wind resistance class for each roller shutter profile can be found in the general information section on page 22ff.

Box dimensions

Front-mounted roller shutters V6

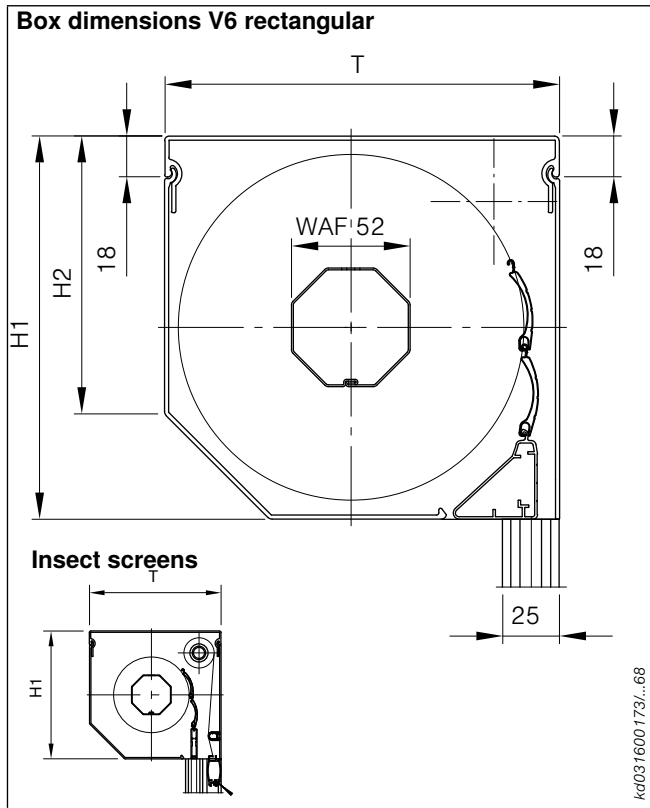

Fig. 11: Box dimensions V6 rectangular

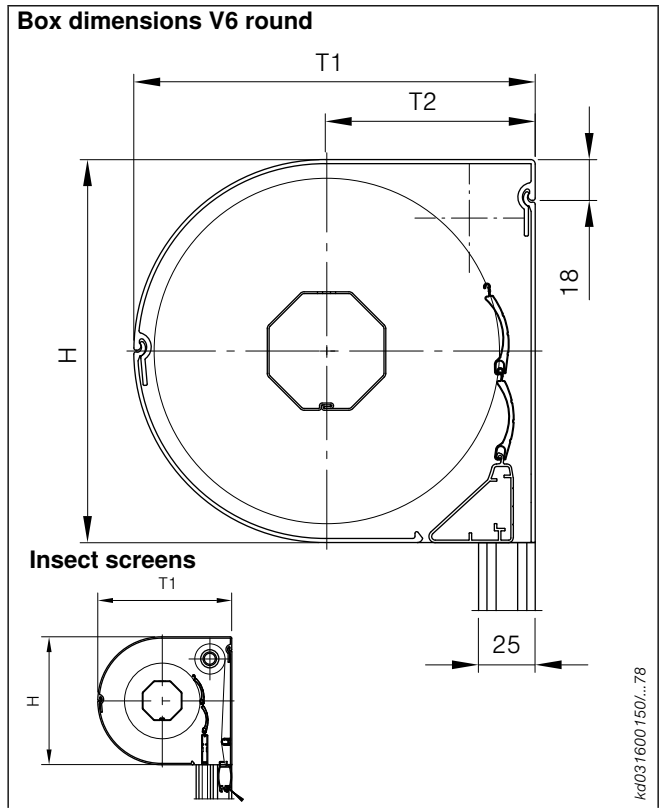

Fig. 12: Box dimensions V6 round

Box size	Dimensions in mm		
	H1	H2	T
12.5	129	92	134
14.5	149	108	154
16.5	169	123	174
18.5	189	137	194
20.5	209	151	214

Notes:

- Box closed on 3 sides as a standard, max. width 3000 mm
- Box optionally closed on 4 sides, max. width 6000 mm
- Available as right rolling blind for boxes closed on 4 sides (for inspection the clearance to other components must be at least box depth).
- Mitre cuts possible (in combination with a box closed on 4 sides).
- An additional box closure is optionally available when using guide rail 55-47 without insect screen (details on page 98).

Box size	Dimensions in mm		
	H	T1	T2
14.5	149	157	80
16.5	169	177	90
18.5	189	197	100
20.5	209	217	110

Please note: Box shape round only available from box size 14.5.

Notes:

- As for V6 rectangular, but not as right rolling blind

Box dimensions

Front-mounted roller shutters V6

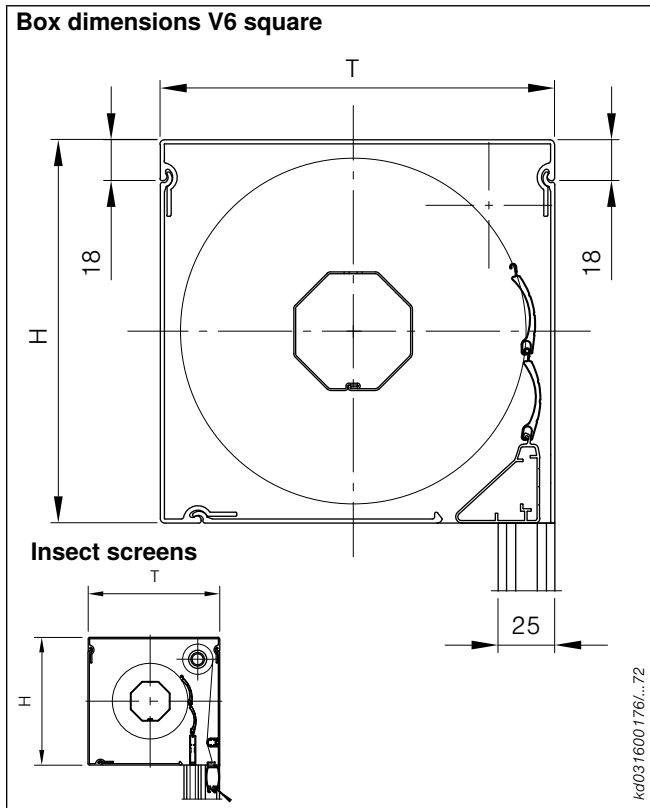

Fig. 13: Box dimensions V6 square

Box size	Dimensions in mm	
	H	T
12.5	129	134
14.5	149	154
16.5	169	174
18.5	189	194

Notes:

- As for V6 rectangular
- available as right rolling blind without limitations

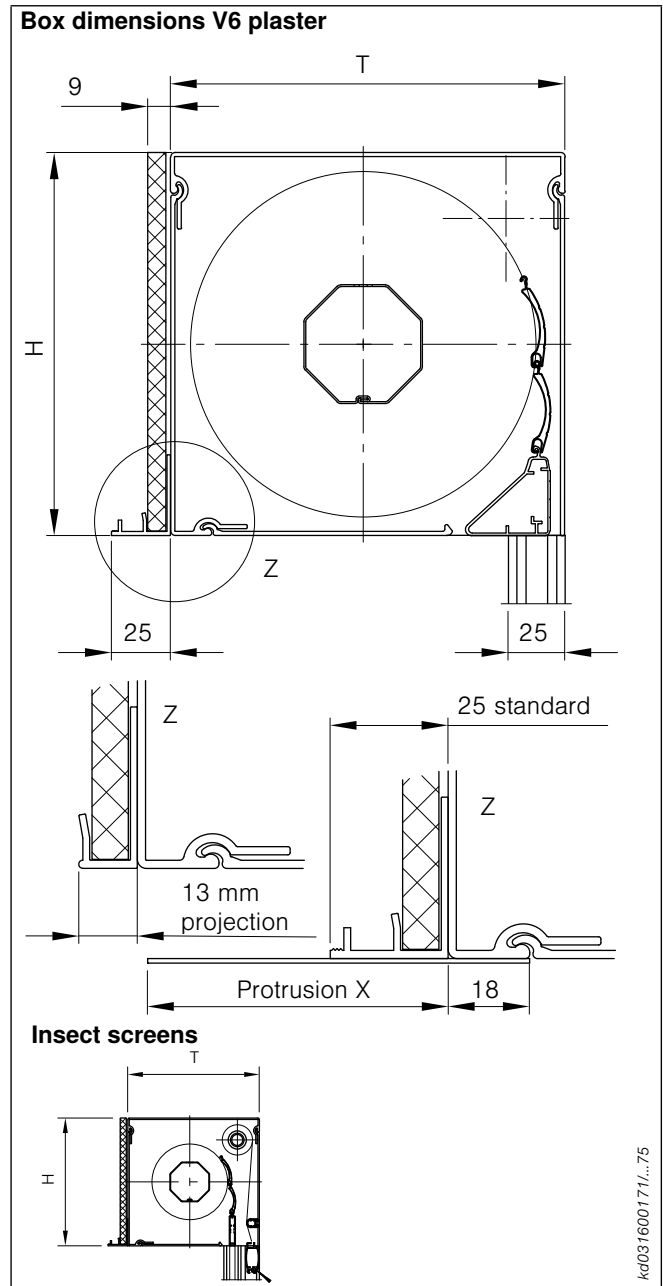

Fig. 14: Box dimensions V6 plaster

For dimensions H and D for each box size see table V6 Square (below Fig. 13).

Notes:

- As for V6 Rectangular, but not as right rolling blind
- Box includes inspection cover, plaster base profile and plaster elements, powder-coated
- for a composite thermal insulation system the distance of the plaster base profile should be set to 13 mm (see Fig. 14). Please indicate on the order.
- The extended plaster base profile is used as a visual closure, it is not suitable for bearing loads from the insulation.

Contents

Front-mounted roller shutters V10

Description	56
Construction limit values	59
Area diagram	61
Box dimensions	62
Solar drive	64

Description

Front-mounted roller shutters V10

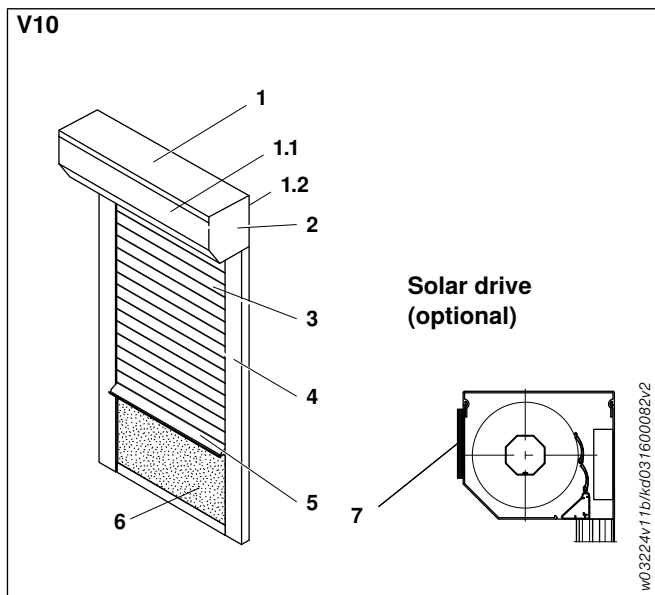

Fig. 15: Front-mounted roller shutters V10

1 Box

1.1 Inspection cover

1.2 Side cover

2 Shaft

3 Roller shutter curtain

4 Lateral guidance

5 End rail

6 Insect screen roller blind (standard)

6.1 Drive via spring-loaded shaft

6.2 Insect screen gauze

6.3 Handle rail

7 Solar panel (optional)

Application

Can be used for retrofitting as well as for new buildings and renovations.

Operation

Motor

with torque overload protection in upper or lower limit position; without operating switch

Voltage: 230 V AC

Frequency: 50 Hz

Protection class: IP 44

Motor cable (l): 1000 mm, optionally 2500 mm, 5000 mm or 10000 mm

EWFS radio motor (optional)

with torque overload protection, EWFS hand-held transmitter 1 channel comprised

Solar drive (optional)

EWFS radio motor incl. EWFS hand-held transmitter with 1 channel with automatic cut-off in upper and lower limit position (adjustable); control and storage battery concealed inside the box

Voltage: 12 V

Protection class: IP 44

Solar panel mounted externally on the box, external panel optional

Power supply unit for emergency power supply optional.

Note: Solar drive not available in combination with insect screen roller blind.

Positioning for solar drive and further details on page 64ff.

Crank

Crank rod with collapsible crank; sealed joint plate and square with thermal separation

Material: aluminium

Surface: C0 anodised, optionally powder-coated in RAL 9016 or anodised C34

Crank holder: plastic, grey, white or brown, crank holder with magnet optional

Belt

Dimensions (w): 14 mm (23 mm only for box shape plaster in combination with a box extension)

Colour: belt winder/brush guiding roller white, brown optional
belt grey, brown optional

Cord

with cord deflection roller and feedthrough device

Dimensions (Ø): 4.5 mm

Colour: cord winder white, brown optional
cord black and white, brown optional

Detailed description of types of drive and operation modes from page 84.

Box (1)

4 box sizes, closed on 4 sides (optionally on 3 sides)

Box shapes: rectangular, round, square, plaster

Material: aluminium, extruded

Dimensions: see table on page 57

Surface: powder-coated, anodising optional (for solar drive generally only powder-coated model possible)

Box available as left-rolling blind.

Maximum box width with insect screen roller blind 2000 mm.

Maximum box width without insect screen roller blind 6000 mm (for box closed on 4 sides) or 3000 mm (for box closed on 3 sides).

Maximum box width with solar drive 2200 mm.

Optional plaster elements 12 mm to 15 mm (plaster elements are a standard with box shape Plaster).

Concealed cut edges on the covers.

Inspection cover (1.1)

Material: aluminium, extruded

Surface: powder-coated, anodising optional

Side covers (1.2)

Material: diecast aluminium

Surface: powder-coated, anodising optional

Description

Front-mounted roller shutters V10

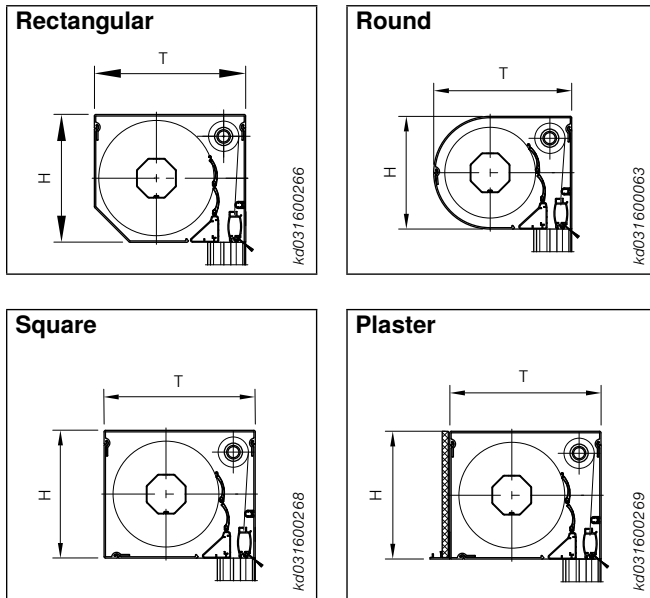

Fig. 16: Box V10

Box dimensions in mm

Box size	Height H	Depth D (R; S; P)	Depth D (R)
14.5	149	180	183
16.5	169	200	203
18.5	189	220	223
20.5 ¹⁾	209	240 ¹⁾	243

¹⁾ Only for box shapes Rectangular and Round.

Shaft (2)

Material: steel, zinc-coated
 Material thickness: 0.8 mm
 Dimensions (WAF): 52 mm
 Profile: octagonal
 Surface: plain

Roller shutter curtain (3)

with light slots

A 36, A 44

Material: aluminium, double walled, foam filled
 Surface: enamelled

K 36

Material: plastic, double walled
 Surface: plastic

S 37

Material: aluminium, double walled, extruded
 Surface: powder-coated

V 36

Material: plastic roller shutter curtain (K 36), every 5th profile is made of aluminium (A 36)
 Surface: plastic/aluminium enamel finish
 Fixing: with pressure springs on the shaft (not for S 37)

Automatic push-up guard through pressure spring locking (not for S 37).

Only profiles A 36 and K 36 can be used with solar drive.

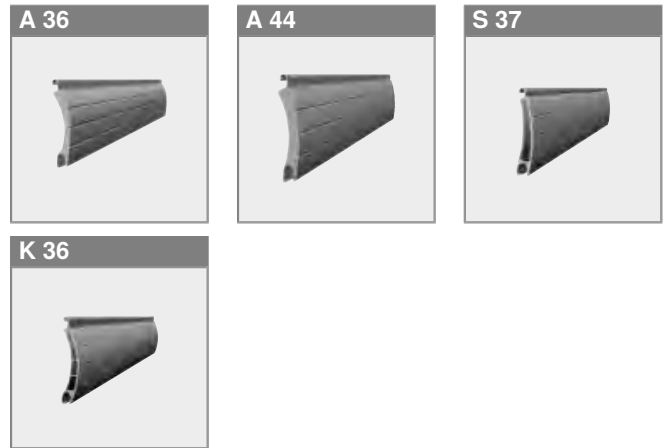

Lateral guidance (4)

Guide rails

Material: aluminium, extruded
 Dimensions: see details on page 109.
 Fixing: stepped drilled hole in the guide rail
 Surface: powder-coated, anodising optional
 Sealing strip: plastic, black, optional brush sealing strip

Plastic cover plug comprised (colour adapted to colour of the guide rails).
 Optionally Minimax guide rails with small visible width available.

End rail (5)

Triangular design end rail, without sealing strip

Material: aluminium, extruded
 Surface: powder-coated, anodising optional
 Triangular design end rail for an attractive closure for belt and crank. On motor operated units it provides almost flush closure.
 Sealing strip optional.

Insect screen roller blind (6) (standard)

Drive via spring-loaded shaft (6.1)

Locking device in the lower section through end cap with catch mechanism. Soft raise function.

Insect screen gauze (6.2)

extremely tear resistant, weatherproof and resistant to corrosion

Material: fibre glass fabric
 Coating: plastic
 Colour: grey, optionally black (for technical reasons the transparent gauze is not available for the insect screen roller blind)

Handle rail (6.3)

Operation: by using the integrated full-width profile
 Material: aluminium, extruded
 Dimensions: 41 x 18 mm
 Surface: powder-coated
 Sealing strip: brush sealing strip sealing towards the window, alternatively downwards (to the window sill)

Description

Front-mounted roller shutters V10

The hand rail is additionally furnished with a cord tassel, length 85 mm.

The handle rail can be optionally fitted a plastic handle shell (available colours: grey, white, black). Fixed for operation alternatively inside, outside or on both sides, for details see page 75.

Insect screen swivel frame (optional)

Especially for large openings, ideal for frequently used balcony and patio doors.

Operation: with handle rail and integrated closing unit

Surface: frame powder-coated

Colour: aluminium parts in colour of box
gauze grey, optionally black transparent gauze (without surcharge)

Insect screen with fixed frame optionally available.

Gauze for swivel or fixed frames optionally as pollen screen or stainless steel gauze.

Note: The integrated solutions provide increased protection against insects. We recommend using a box closed on 4 sides.

Please note the details about insect screen roller blinds and swivel frames on page 74 pp.

Locking device integrated into flat end rail, alternatively with

- espagnolette lock, lockable from inside and outside (only available for models without insect screen roller blind; lock must be accessible).
- Sliding bolt (operated from inside). Details see page 120.

Colours

Powder coating of aluminium parts (except roller shutter curtains) with chrome-free pre-treatment in accordance with valid RAL CLASSIC colour chart (except camouflage and luminous colours) or in DB colours 701, 702 and 703, as well as eight textured colours (W4914 - W4921), four anodised-look colours (WC31 - WC34), and further colours according to WAREMA standard colour chart (in WAREMA colour specification). Alternatively also C0 anodised in natural colour.

Other colour specifications, special colours or colour anodising are available upon request and at a surcharge.

Roller shutter curtain according to WAREMA colour chart for roller shutter profiles.

Accessories

Minimax guide rails with small visible width. For details see page 94.

Projecting arm (guide rails with projection arm): The guide rails can be projected together with the lowered roller shutter curtain using the manually operated projection arm. In combination with an insect screen roller blind (minimum height for roller shutter 1100 mm), for details see page 73.

Security package for advanced security requirements in accordance with DIN 18073:

Includes: reinforced push-up guard, inspection cover and guide rails with advanced protection against dismantling, protection against prying out the box, highly rigid triangular design end rail or flat end rail with locking device with sliding bolt, reinforced guide rails, roller shutter curtains within the maximum box width for wind resistance class 6. Details see page 95.

Construction limit values

Front-mounted roller shutters V10

You can also use our free planning program at www.sonnenschutzplaner.de for planning the sun shading systems – configure the product and generate a technical drawing that can be integrated into your plans.

More installation examples for different wall structures for use in consultations can be found in our roller shutter application brochure, art. no. 213901.

Roller shutter curtain		Limit values ¹⁾			Operation modes and max. areas in m ²										
		max. width in mm	max. height in mm	max. area for individual unit in m ²	Cord	Belt, internal	Belt with pull-out belt disc	Step-up gear for belt	Crank winder for belt	Crank type 1, internal	Crank type 2, internal	Crank with pull-out gear	Motor with torque over-load protection	EWFS radio motor	Solar drive
Front-mounted roller shutters V10															
A 36	design-related				2.0	4.0	3.0	8.0	6.0	5.0	8.0	3.0			
	DIN EN 13659 cl. 1	3000	3500	7.0	1.0	2.0	2.0	4.0	3.0	5.0	8.0	3.0	15.0	13.0	3.5
	DIN EN 13659 cl. 2				0.5	1.0	1.0	2.0	1.5	3.0	5.5	3.0			
A 44	design-related				1.5	4.0	3.0	7.0	6.0	5.0	8.0	3.0			
	DIN EN 13659 cl. 1	3500	2900	10.0	1.0	2.0	2.0	4.0	3.0	5.0	8.0	3.0	13.0	11.5	-
	DIN EN 13659 cl. 2				0.5	1.0	1.0	2.0	1.5		4.5	2.5			
S 37	design-related				-	-	-	-	-	-	3.5	-			
	DIN EN 13659 cl. 1	3000	2800	7.0	-	-	-	-	-	-	3.5	-	7.0	4.5	-
	DIN EN 13659 cl. 2				-	-	-	-	-	-	2.5	-			
K 36	design-related				1.5	4.0	3.2	7.0	6.0	5.0	8.0	3.2			
	DIN EN 13659 cl. 1	2000	3000	3.2	1.0	2.0	2.0	4.0	3.0	5.0	8.0	3.0	13.0	11.5	3.2
	DIN EN 13659 cl. 2				0.5	1.0	1.0	2.0	1.5	2.5	4.5	2.5			
V 36	design-related				1.5	4.0	3.0	7.0	6.0	5.0	8.0	3.0			
	DIN EN 13659 cl. 1	2200	3000	4.0	1.0	2.0	2.0	4.0	3.0	5.0	8.0	3.0	13.0	11.5	-
	DIN EN 13659 cl. 2				0.5	1.0	1.0	2.0	1.5		4.5	2.5			
	Insect screen roller blind	2000	2500	5.0											
	Insect screen swivel frame ²⁾	1300	2700	2.7											
	Min. order width in mm				500	500	500	500	500		500	500	640	660	660
	min. order width with insect screen roller blind in mm (with soft raise function)				760	760	760	760	760		760	760	760	760	-
	min. order width with insect screen roller blind in mm (without soft raise function)				570	570	570	570	570		570	570	640	660	-

¹⁾ These values are not applicable for V10 with solar drive

²⁾ Insect screen swivel frame with one wing; for two wings the maximum widths and areas are doubled

Please note the relevant area diagram when determining the maximum areas.

Notes:

- For coupled units (max. 3 curtains) please add 10% of the roller shutter area per coupling to compensate for friction!
- For roller shutters with profile S 37 coupling and continuous cover panels are not available.
- From order widths of over 1500 mm we recommend additional box fastening. Details see page 97.

Construction limit values

Front-mounted roller shutters V10

Max. ordering heights per box size in mm

Box size	Roller shutter profile				
	A 36	A 44	S 37	K 36	V 36
14.5	1900 (1850)	1100	1700	1900 (1850)	1900
16.5	2750 (2600)	1700	2400	2650 (2600)	2650
18.5	3250 (2750)	2350	2800	3000 (2750)	3000
20.5	3500 (2750)	2900	2800	3000 (2750)	3000

Note:

- The values in brackets refer to units with solar drive. Further information on page 65.
- Box size 20.5 is not available in combination with Mini-max guide rails.

Area diagram

Front-mounted roller shutters V10

Maximum dimensions for individual areas V10 with plastic roller shutter curtain in mm

Height	Width													
	900	1000	1100	1200	1300	1400	1500	1600	1700	1800	1900	2000	2100	2200
1000														V 36
1100														
1200														
1300														
1400														
1500														
1600														
1700														
1800														
1900														
2000														
2100														
2200														
2300														
2400														
2500														
2600														
2700														
2800														
2900														
3000		K 36	V 36											

Maximum dimensions for individual areas V10 with aluminium roller shutter curtain in mm

Height	Width																											
	900	1000	1100	1200	1300	1400	1500	1600	1700	1800	1900	2000	2100	2200	2300	2400	2500	2600	2700	2800	2900	3000	3100	3200	3300	3400	3500	
1000																												
1100																												
1200																												
1300																												
1400																												
1500																												
1600																												
1700																												
1800																												
1900																												
2000																												
2100																												
2200																												
2300																												
2400																												
2500																												
2600																												
2700																												
2800		S 37																										
2900		A 44																										
3000																												
3100																												
3200																												
3300																												
3400																												
3500		A 36																										

The wind resistance class for each roller shutter profile can be found in the general information section on page 22ff.

Box dimensions

Front-mounted roller shutters V10

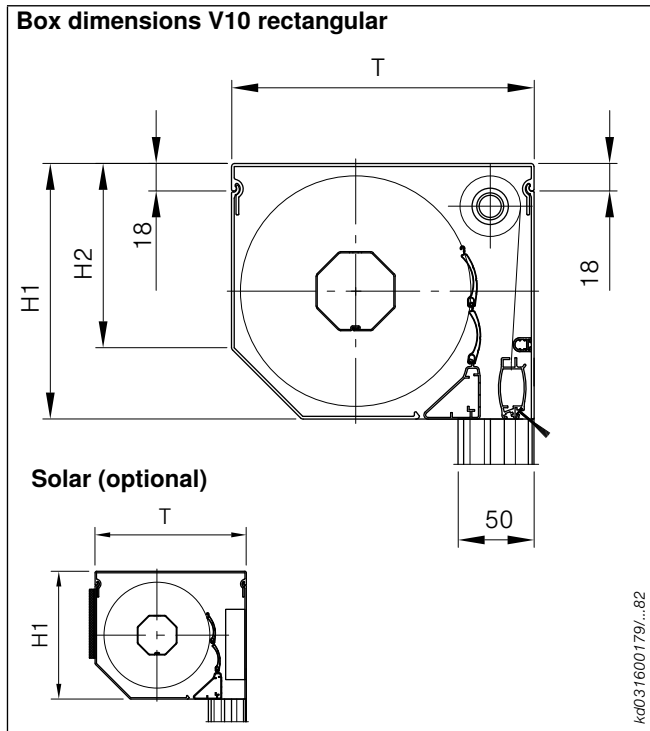

Fig. 15: Box dimensions V10 rectangular

Box size	Dimensions in mm		
	H1	H2	T
14.5	149	108	180
16.5	169	123	200
18.5	189	137	220
20.5	209	151	240

Notes:

- Box closed on 4 sides as a standard, max. width 6000 mm
- Box optionally closed on 3 sides, max. width 3000 mm
- Mitre cuts possible for box closed on 4 sides
- Deviating max. dimensions for insect screen and solar drive in table page 60.

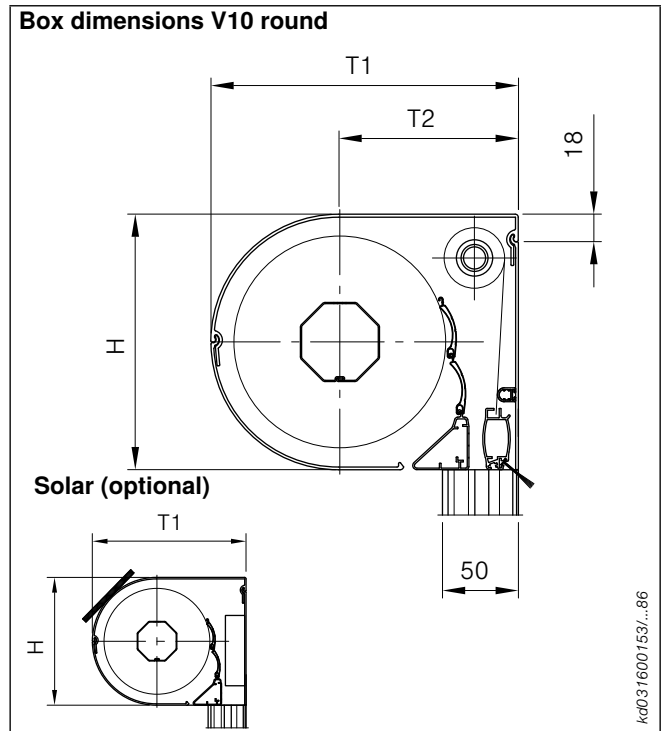

Fig. 16: Box dimensions V10 round

Box size	Dimensions in mm		
	H	T1	T2
14.5	149	183	106
16.5	169	203	116
18.5	189	223	126
20.5	209	243	136

Notes:

- As for V10 rectangular

Box dimensions

Front-mounted roller shutters V10

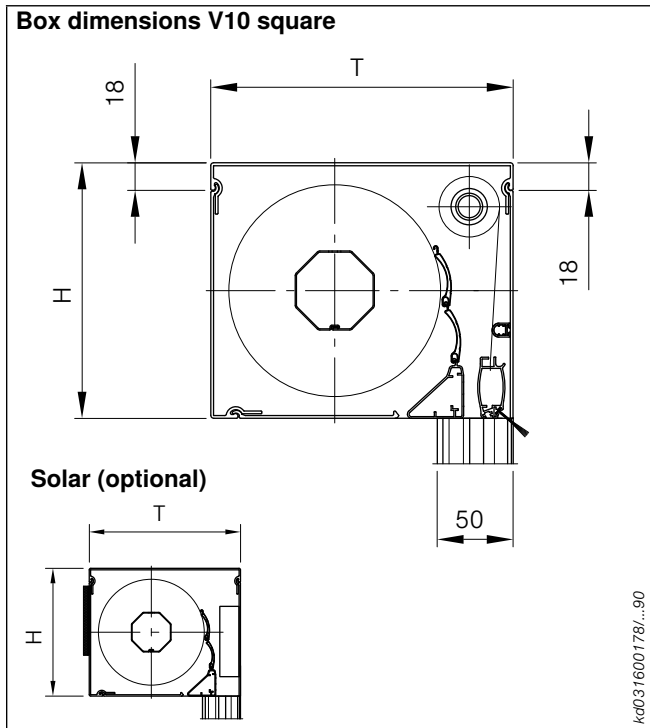

Fig. 17: Box dimensions V10 square

Box size	Dimensions in mm	
	H	T
14.5	149	180
16.5	169	200
18.5	189	220

Notes:

- As for V10 rectangular

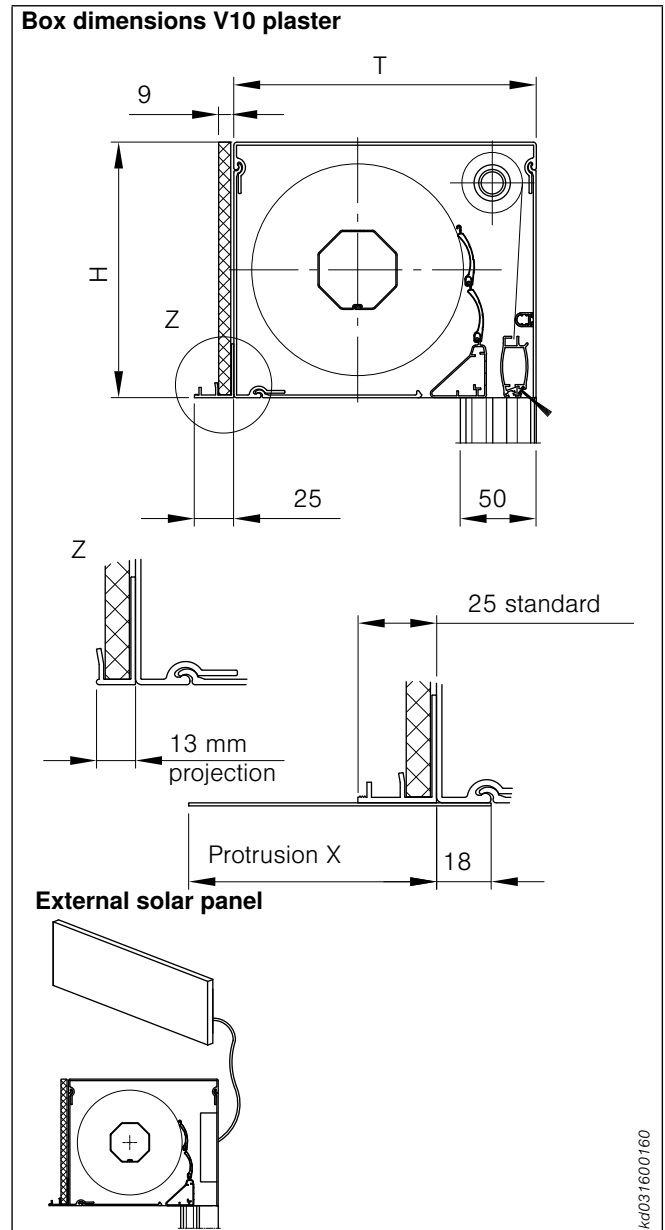

Fig. 18: Box dimensions V10 plaster

For dimensions H and D for each box size see table V10 square (below Fig. 17).

Notes:

- As for V10 rectangular
- Solar drive (optional): Solar panel included, not mounted. Mounting on site
- Box includes inspection cover, plaster base profile and plaster elements, powder-coated
- When covering with a composite thermal insulation system the distance of the plaster lathing can be adapted accordingly. Please indicate on the order.
- The extended plaster base profile is used as a visual closure, it is not suitable for bearing loads from the insulation.

Positioning Solar drive

When planning the installation it must be ensured that there are no objects which could impede operation of the roller shutter, as described in the following.

As a rule of thumb it must be ensured that the sky is directly visible from the viewpoint of the solar panel.

If the shutters are mounted in a northern, north-western or north-eastern direction the solar panel should have an unhindered view of the sky in all directions.

The possible incidence area must not fall below 60° to the horizontal.

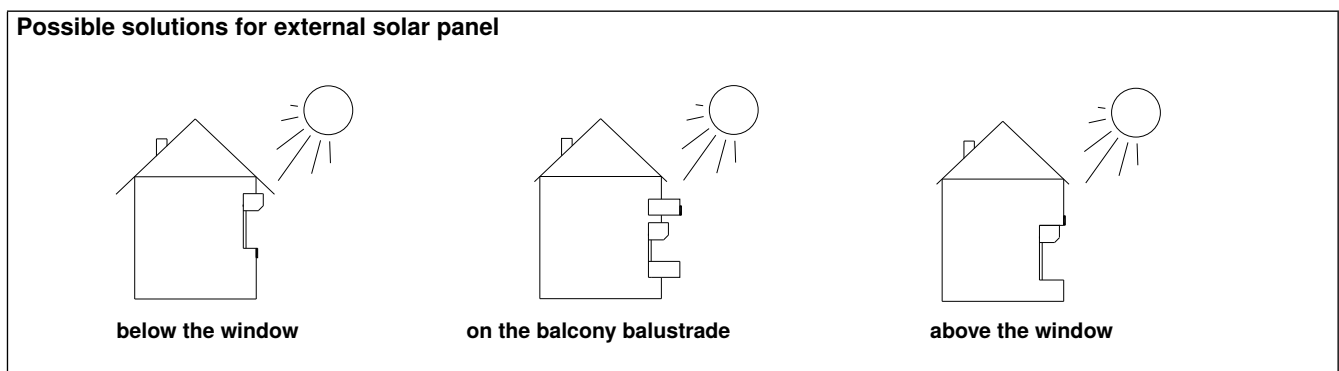
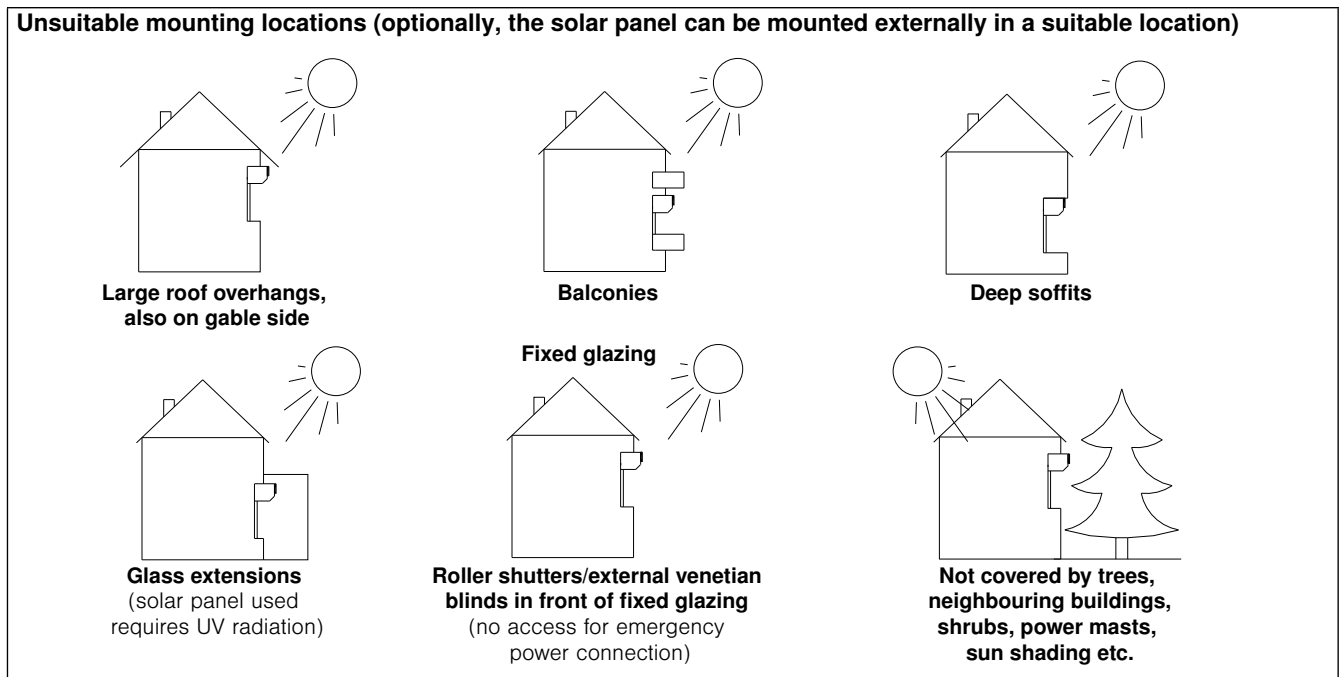
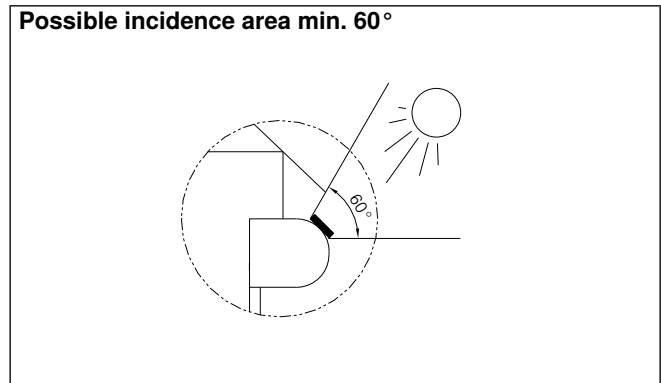
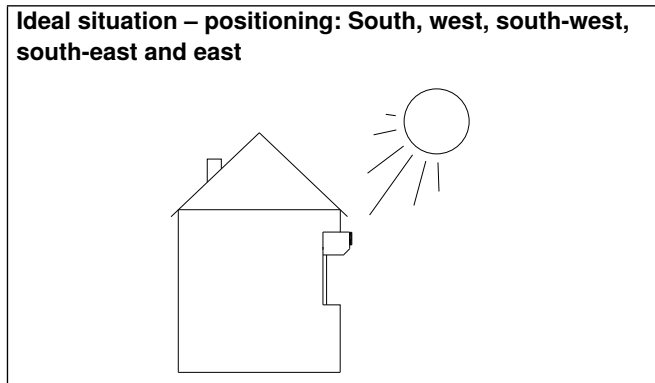

Technical information/data

Solar drive

Roller shutter curtain	Limit values			Operation modes and max. areas in m ²		
	Max. width in mm	Max. height in mm	Max. area for individual unit in m ²	Solar drive	1 solar panel	2 solar panels
Front-mounted roller shutter V10 with solar drive						
A 36	2200	2750	3.5	3.5	3.5	3.5
K 36	2000	2750	3.2	3.2	3.2	3.2
Min. order width in mm				660	660	1320

Notes:

- The minimum width must be observed, as the solar panel has to be offset on the box by 25 mm on each side of its width!
- Units cannot be coupled
- Please observe the maximum measurements for individual areas

Technical data

	min.	typ.	max.	unit
Supply				
Operating voltage (stand-by)	11.2	12	13.8	V DC
Internal current consumption	0.3	0.6	1.3	mA DC
Output				
Output voltage (active)	11.2	12	13.8	V DC
Output current	0	2.1	3.5	A DC
Solar panel				
Peak power			4.0	W _{peak}
No-load voltage	0		22.0	V
Nominal voltage		16.5		V
Dimensions of the solar panel				
Length of		605		mm
Width		85		mm
Thickness		11		mm
Ambient conditions				
Operating temperature	-20	20	70	°C
Storage temperature	-20		70	°C
Humidity (not condensing)	10	40	80	%F _{rel}
EWFS hand-held transmitter				
Range			30	metres
Motor data				
Supply voltage				V DC
Power		12		W
Nominal current		2.7		A DC
Tensile force			10	Nm

Technical information/data

Solar drive

General information:

- The use of an insect screen roller blind is not possible in combination with a solar drive
- only powder-coated surfaces are available in connection with solar drives (no anodising)!
- Guide rail size 55x52 mm is generally used for solar drives
- The motor is always positioned on the side opposite the solar panel
- for external mounting of the solar panel: the extended cable is not resistant to UV rays. We recommend laying the cable inside a cable conduit.

Solar-powered control

- Designed to allow operation of the front-mounted roller shutter with solar drive min. 2x per day even under average light conditions (cloudy sky).
- Shortages possible during very long periods of bad weather
- Operation via hand-held radio transmitter

Charging the storage battery

- The charging capacity depends on the direct solar radiation and the duration.
- The higher the incidence of solar radiation, the higher the charging capacity

Optional second solar panel

For frequent operation or unfavourable positioning of the roller shutter it is recommended to install a second solar panel:

- This doubles the charging capacity
- External retrofitting (i.e. not on the element) possible

Internal protective function

- Sets in on low charge of the storage battery
- Roller shutter will only move "down" if there is sufficient energy to move "up" after moving "down"
- The control also ensures overload protection for the storage battery.

Emergency power supply

- Possible with separate power supply unit, the roller shutter will still be operated using the hand-held radio transmitter
- Power supply unit not suitable for charging the storage battery
- Power supply unit to be ordered separately

Care and maintenance

The solar panel should be free of dirt in order to guarantee operating safety.

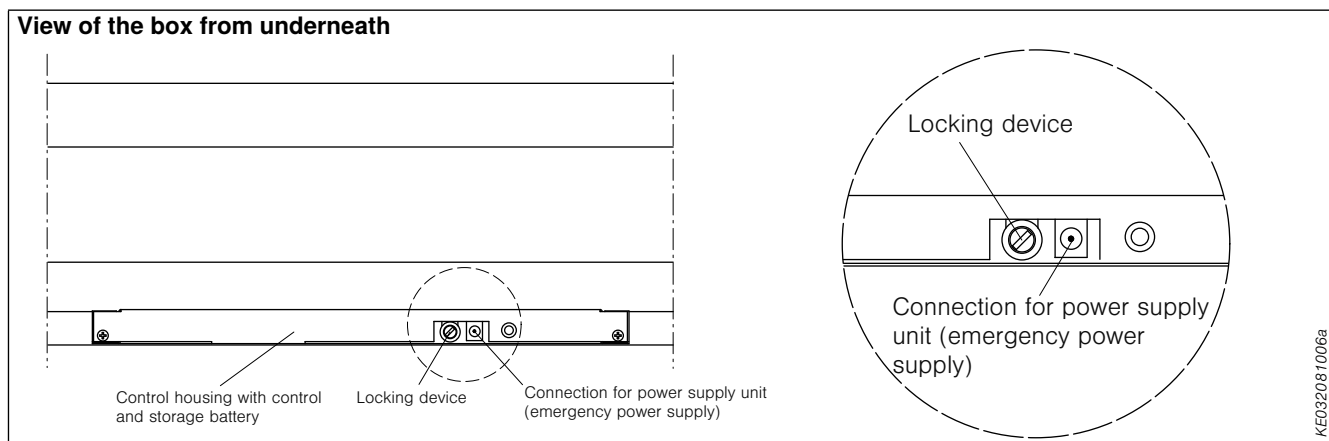

Fig. 17: View of the box from underneath

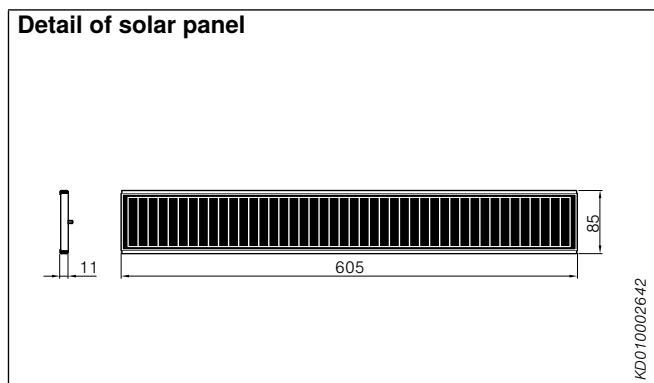

Fig. 18: Detail of solar panel

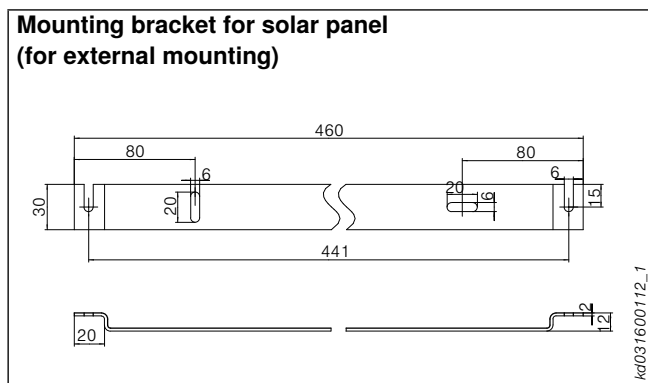

Fig. 19: Mounting bracket for solar panel (for external mounting)

Contents

Determining dimensions/order data

Measuring instructions for front-mounted roller shutters.	68
Front-mounted roller shutters V4/V6	69
Front-mounted roller shutters V10	72
Front-mounted roller shutter with insect screen roller blind	74
Front-mounted roller shutter with insect screen swivel frame	76
Font-mounted roller shutter V10 solar	80
Determining dimensions/order data for combinations	81
Details of belt operation	84
Details of belt/cord operation with crank winder	88
Cord operation details	89
Crank operation details	90
Motor operation details.	92

Overview

Front-mounted roller shutters V4

Front-mounted roller shutters V6

Front-mounted roller shutters V10

Determining dimensions/operating details

Additional options

Guide and end rails

Security roller shutters

Front-mounted external venetian blinds

Accessories Roller shutter curtains

Control systems

Measuring instructions for front-mounted roller shutters

Mounting in the reveal/guide rails with diagonal cut

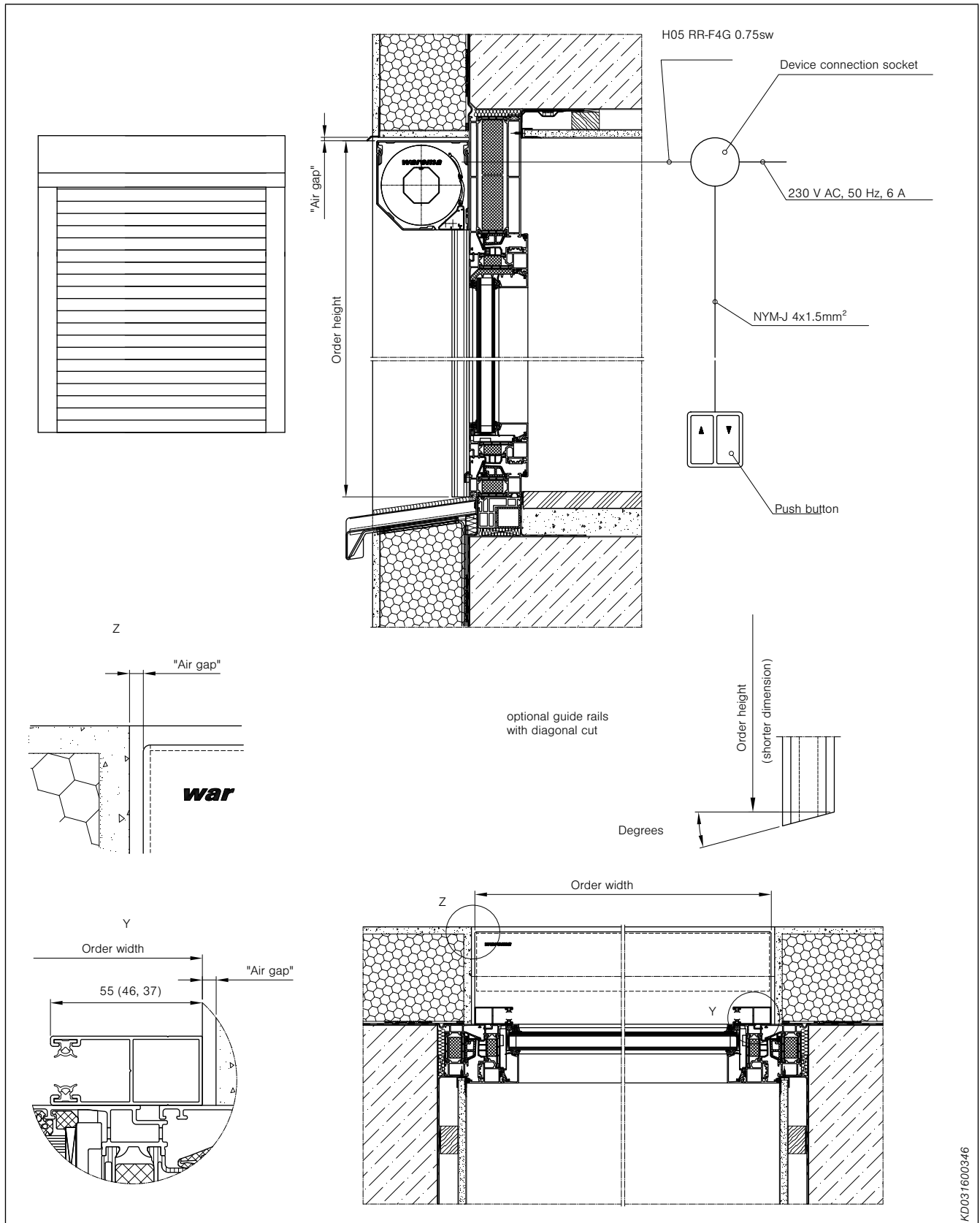

KD031600346

Fig. 20: Measuring instructions for individual unit front-mounted roller shutter – installation in the reveal

Determining dimensions/order data

Front-mounted roller shutters V4/V6

General information on order data for left rolling blinds

- Note deductions measurements (see details)
- Order width = back edge of guide rails
- Order height = bottom edge of guide rail to top edge of box
- Operation side, seen from inside
- State box size if not standard (see construction limit values)
- State plaster elements if necessary
- State insect screens for V4/V6 separately

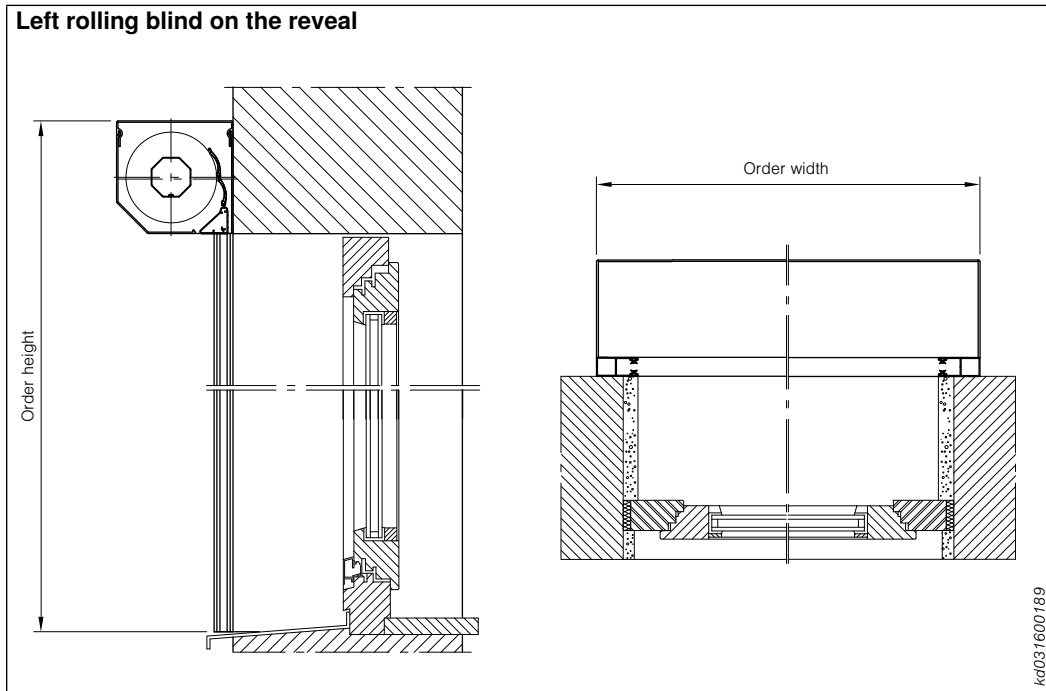

Fig. 21: Left rolling blind on the reveal

Type matrix

V4	○	○	○	○
V6	○	○	○	○

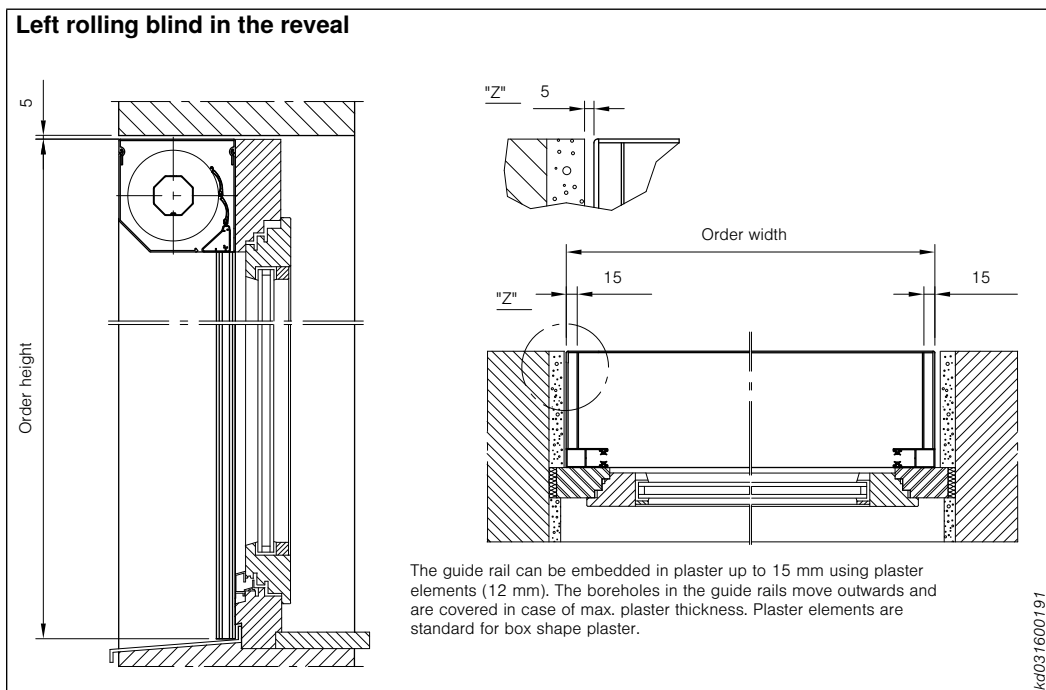

Fig. 22: Left rolling blind in the reveal

Type matrix

V4	○	○	○	○
V6	○	○	○	○

Determining dimensions/order data

Front-mounted roller shutters V4/V6

General information on order data for left rolling/right rolling blinds

- Note deductions measurements (see details)
- Order width = back edge of guide rails
- Order height = bottom edge of guide rail to top edge of box
- Operation side, seen from inside
- State box size if not standard (see construction limit values)
- State plaster elements if necessary. Plaster elements are standard for box shape plaster.
- Right rolling blind with box shape rectangular: For inspection the clearance to other components must be at least equivalent to box depth
- If Minimax guide rails are used, a right rolling model is not available.

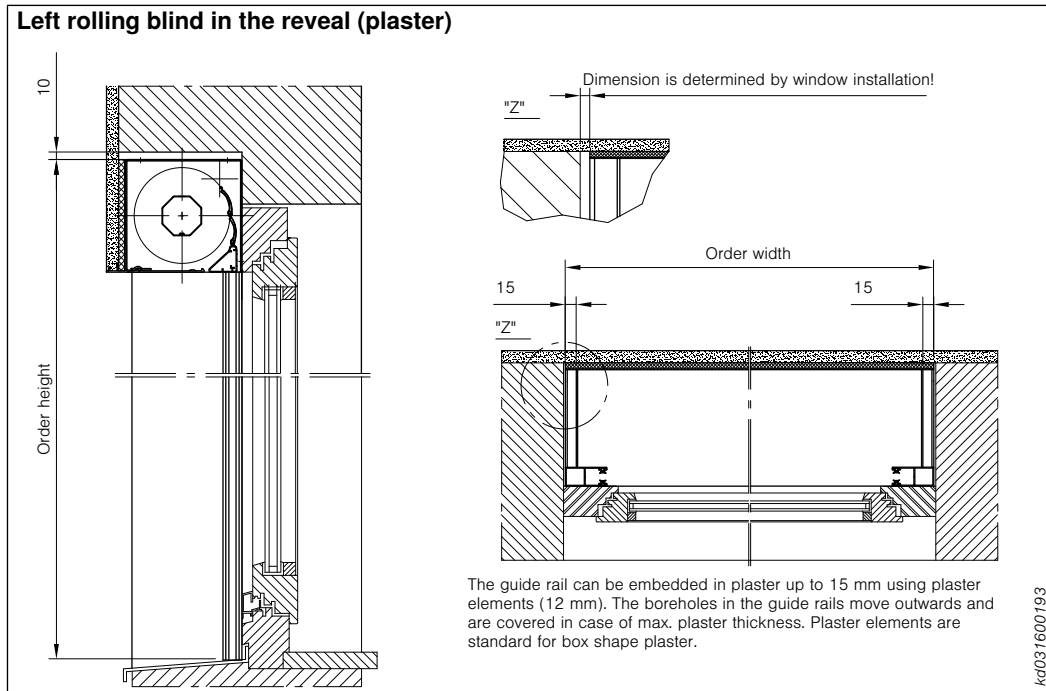

Type matrix

V4	-	-	-	o
V6	-	-	-	o

Fig. 23: Left rolling blind in the reveal (plaster)

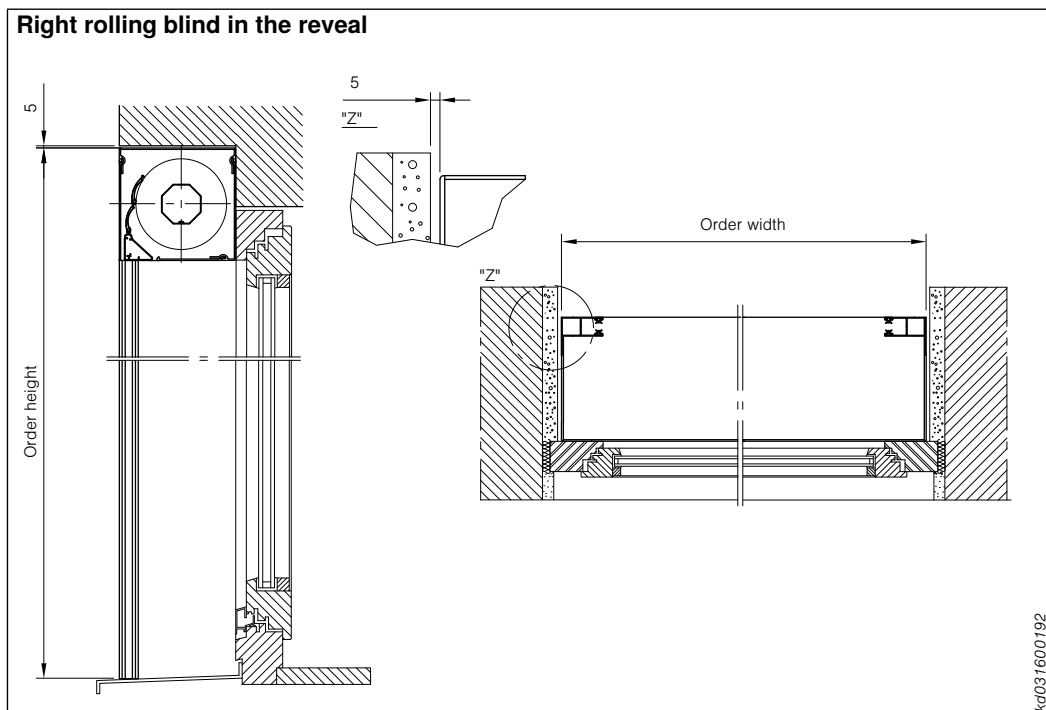

Type matrix

V4	-	-	-	-
V6	o	-	o	-

Fig. 24: Right rolling blind in the reveal

Determining dimensions/order data

Front-mounted roller shutters V4/V6

General information on order data for left rolling roller blinds with projection arm

- Min. order height 1100 mm
- Max. order height 2500 mm
- Max. order width (see table in the figure)
- Hinges and projection arms in black
- State insect screens in the projection arm for V4/V6 separately
- Units with projection arm cannot be coupled and embedded in plaster.
- Projection unit not available in combination with Minimax guide rails.

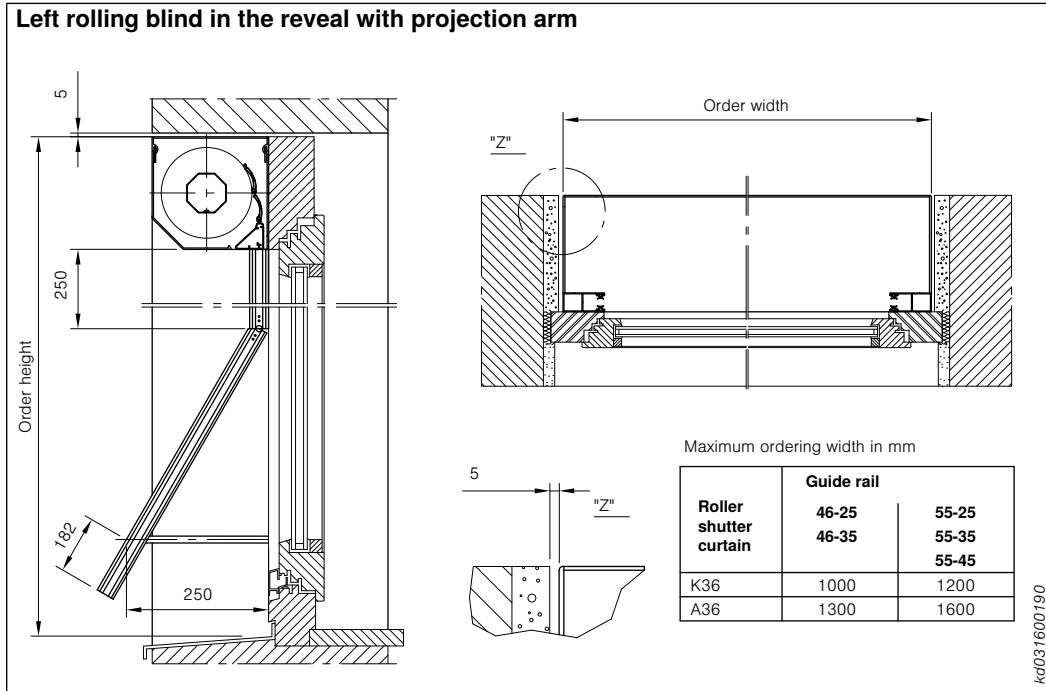

Fig. 25: Left rolling blind in the reveal with projection arm

Type matrix

V4	○	○	○	-
V6	○	○	○	-

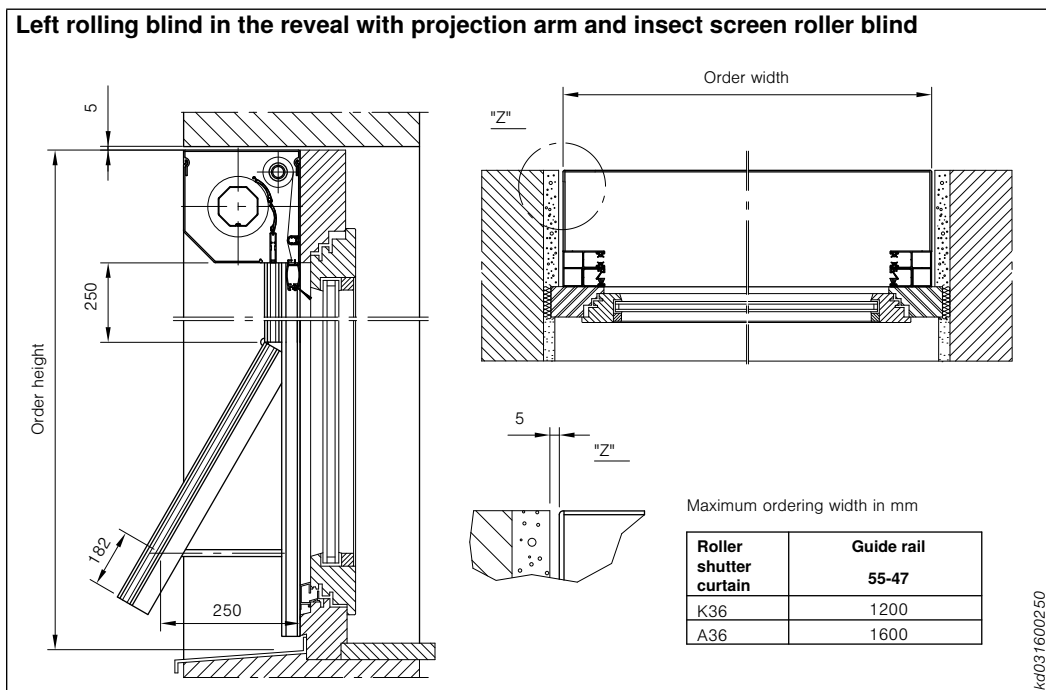

Fig. 26: Left rolling blind in the reveal with projection arm and insect screen roller blind

Type matrix

V4	○	○	○	-
V6	○	○	○	-

Determining dimensions/order data

Front-mounted roller shutters V10

General information on order data for left rolling blinds with insect screen roller blind

- Note deductions measurements (see details)
- Order width = back edge of guide rails
- Order height = bottom edge of guide rail to top edge of box
- Operation side, seen from inside
- State box size if not standard (see construction limit values)
- State plaster elements if necessary. Plaster elements are standard for box shape plaster.

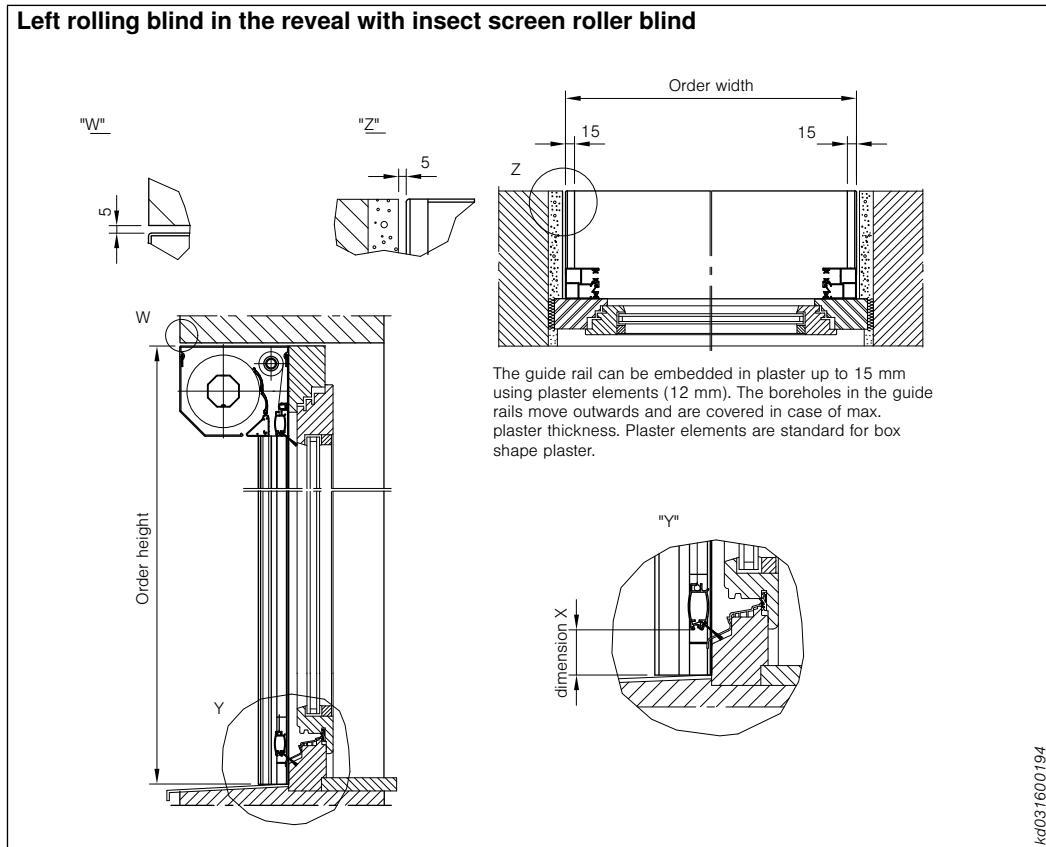

Type matrix

V10	○	○	○	○

Fig. 27: Left rolling blind in the reveal with insect screen roller blind

Determining dimensions/order data

Front-mounted roller shutters V10

General information on order data for left rolling blinds with projection arm and insect screen roller blind

- Min. order height 1100 mm
- Max. order height 2500 mm
- Max. order width (see table in the figure)
- Hinges and projection arms in black
- Units with projection arm cannot be coupled and embedded in plaster
- Projection unit not available in combination with Minimax guide rails.

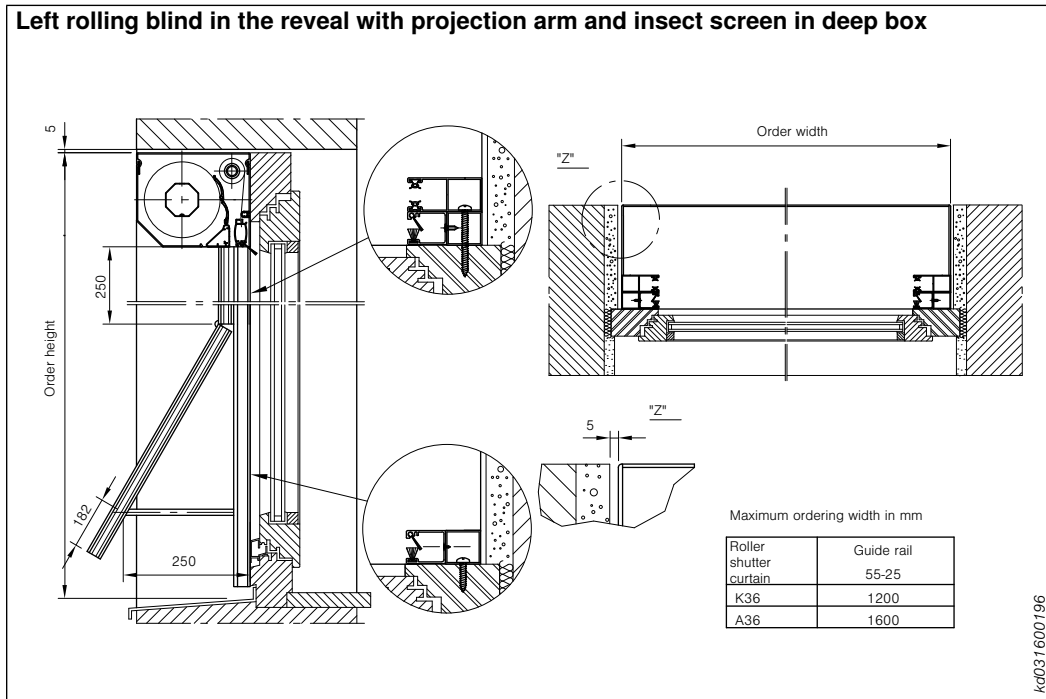

Fig. 28: Left rolling blind in the reveal with projection arm and insect screen in deep box

Type matrix

V10	○	○	○	-

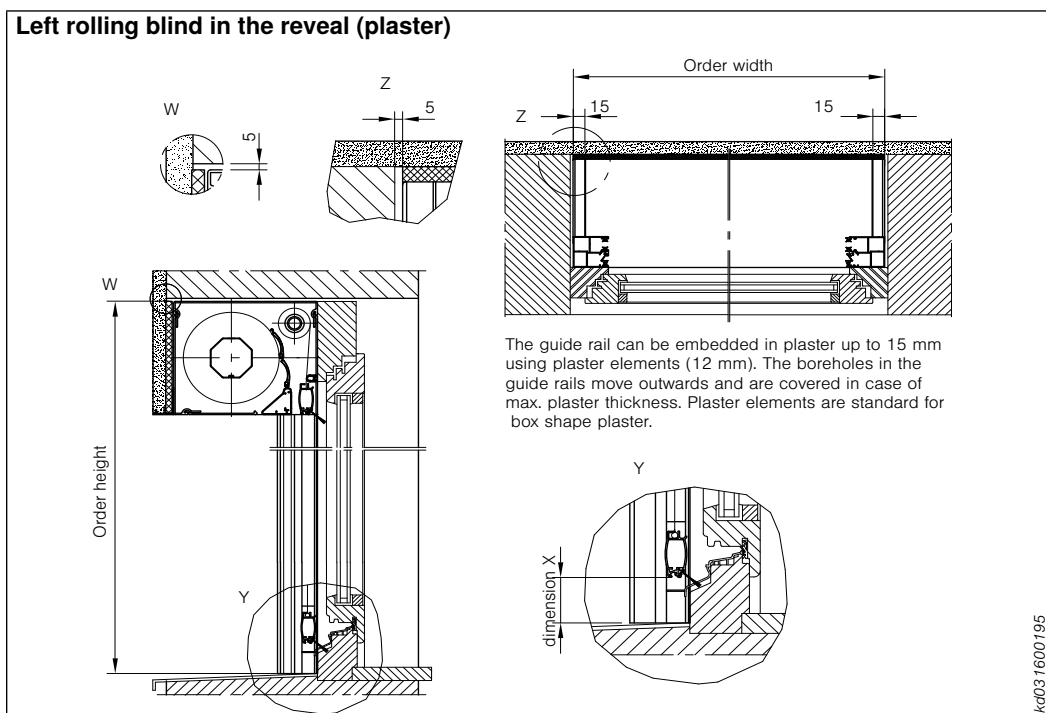

Fig. 29: Left rolling blind in the reveal (plaster)

Type matrix

V10	-	-	○	-

Determining dimensions/order data

Front-mounted roller shutter with insect screen roller blind

Standard scope of delivery for insect screen roller blinds:

- Incl. shaft, curtain, guide rails for insect screen roller blind and handle rail
- Curtain: gauze made from plastic coated fibreglass fabric in grey
- Handle rail, powder-coated, incl. brush sealing strip in the lower groove for sealing (sealing to the window frame)
- Cord tassel 85 mm
- Drive via spring-loaded shaft
- Locking device in the lower section via end cap with catch mechanism

- Smooth operation through soft raise function (minimum width 760 mm)

Optional:

- Black gauze
- Recessed plastic handle, in grey, white or black (adapted to the colour of the aluminium handle rail). Mounting alternatively for operation from inside, outside or both sides.
- Cord tassel 600 mm
- Handle rail with brush sealing strip diagonally towards the back or alternatively sealing towards the bottom (window sill)

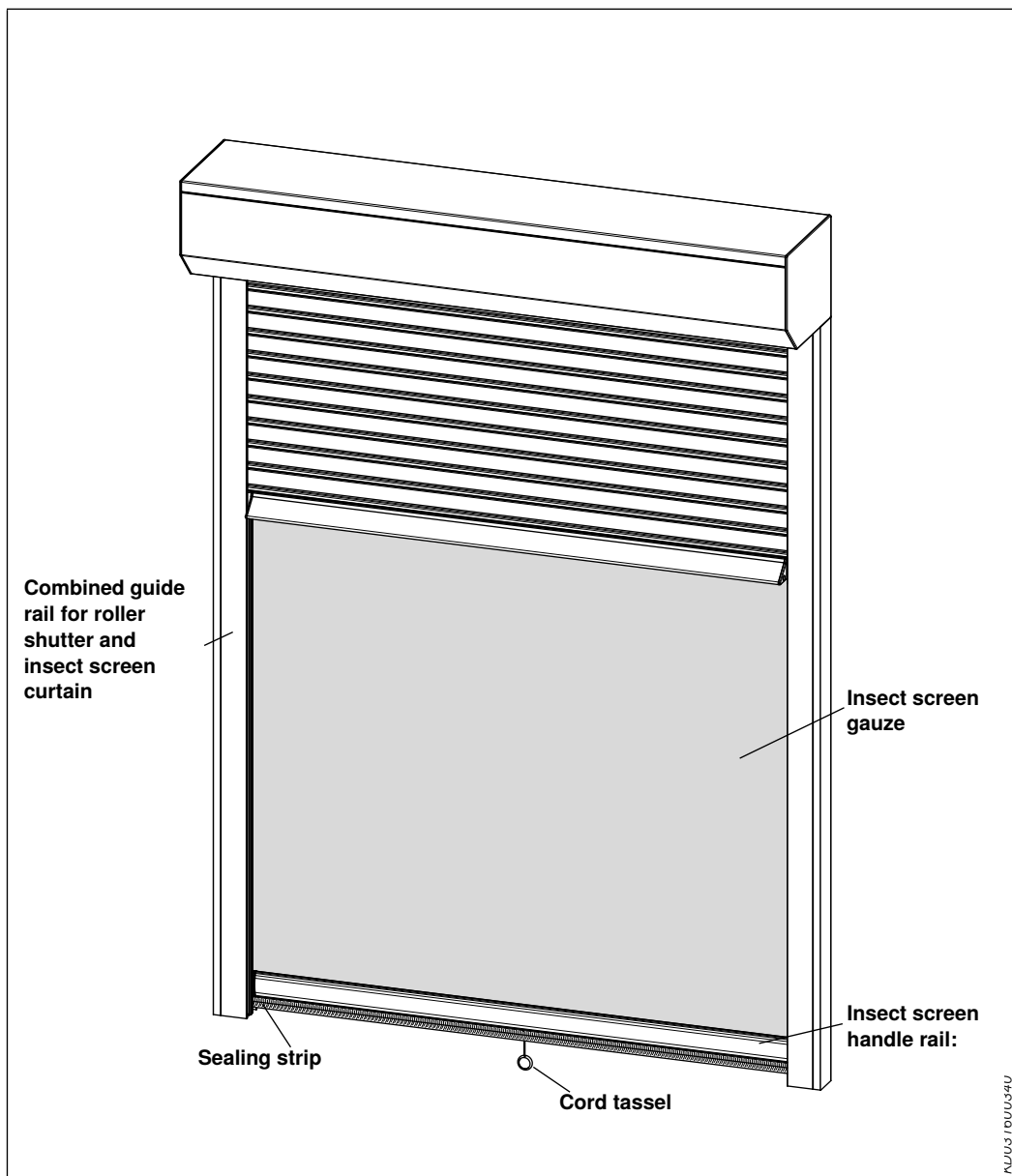

Type matrix

V4	○	○	○	○
V6	○	○	○	○
V10	●	●	●	●

Fig. 30: Front-mounted roller shutters with integrated insect screen roller blind

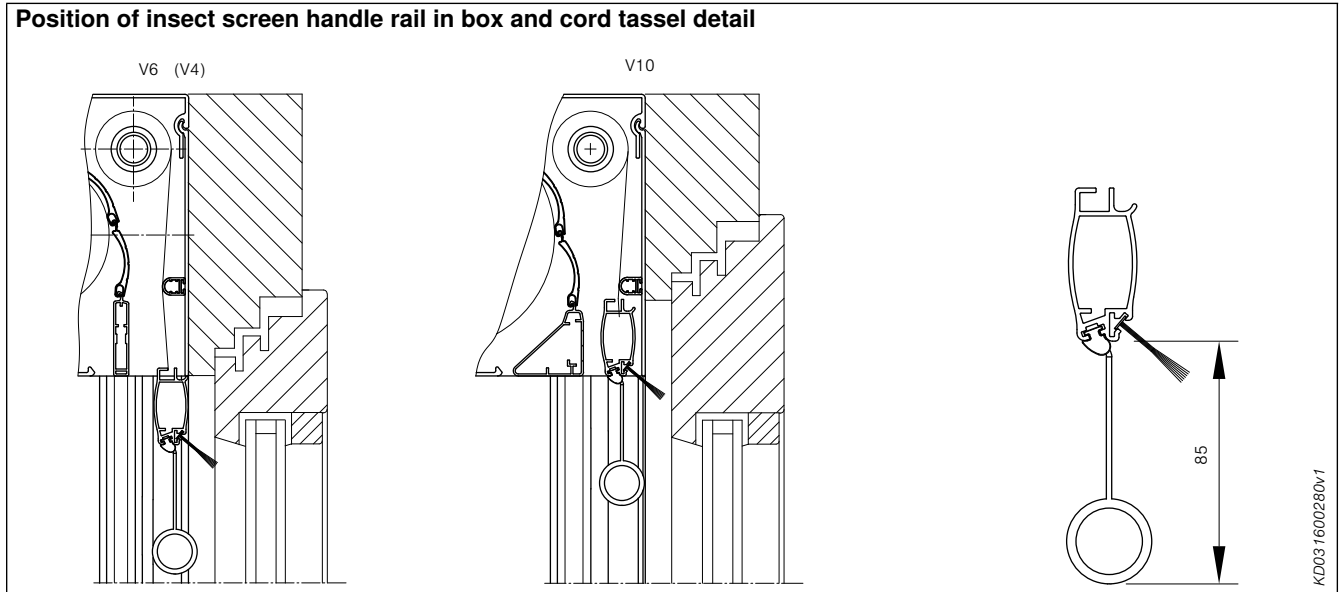

Fig. 31: Position of insect screen handle rail in box and cord tassel detail

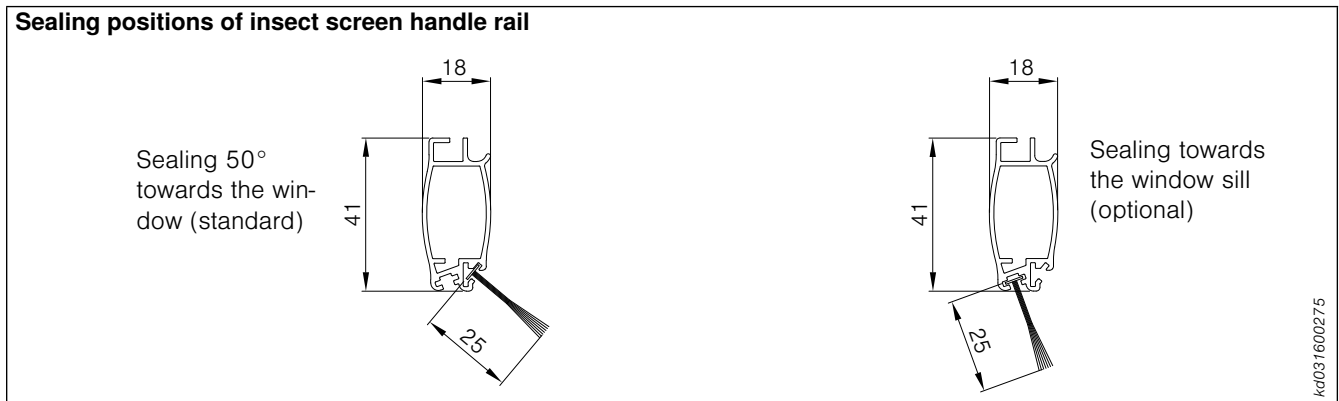

Fig. 32: Sealing positions of insect screen handle rail

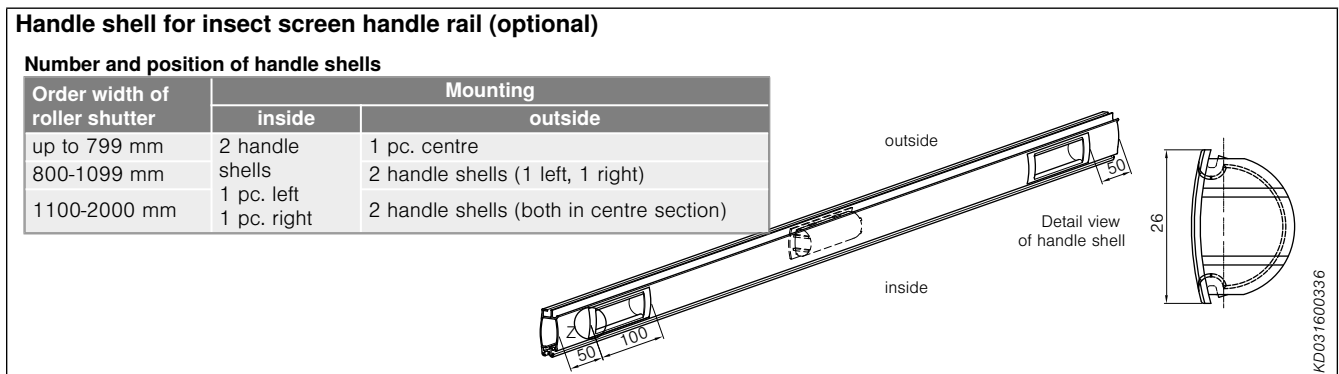

Fig. 33: Handle shell for insect screen handle rail

Determining dimensions/order data

Front-mounted roller shutter with insect screen swivel frame

Standard scope of delivery for insect screen swivel frame:

- Insect screen swivel frame with brush sealing strip and magnetic strip inserted, incl. mounting frame
- Brush sealing strip sealing towards the window (state dimension X)
- Gauze made of plastic-sheathed fibre glass fabric, grey
- Hinges and fixing screws
- Includes automatic door closing unit
- from a side hung window height of 1500 mm; incl. central support rail made of extruded aluminium, dim. 10x25 mm, powder-coated; without integrated handle rail

- from a side hung window height of 1800 mm; incl. central support rail made of extruded aluminium, dim. 10x52 mm, powder-coated with integrated handle rail, incl. kick plate
- Powder coated in roller shutter colour (box/guide rails)

Optional:

- Gauze in colour black, highly transparent
- Sealing bottom brush sealing strip "to the window sill"
- Other bar position possible (state dimension W)
- Additional bars
- Stainless steel gauze

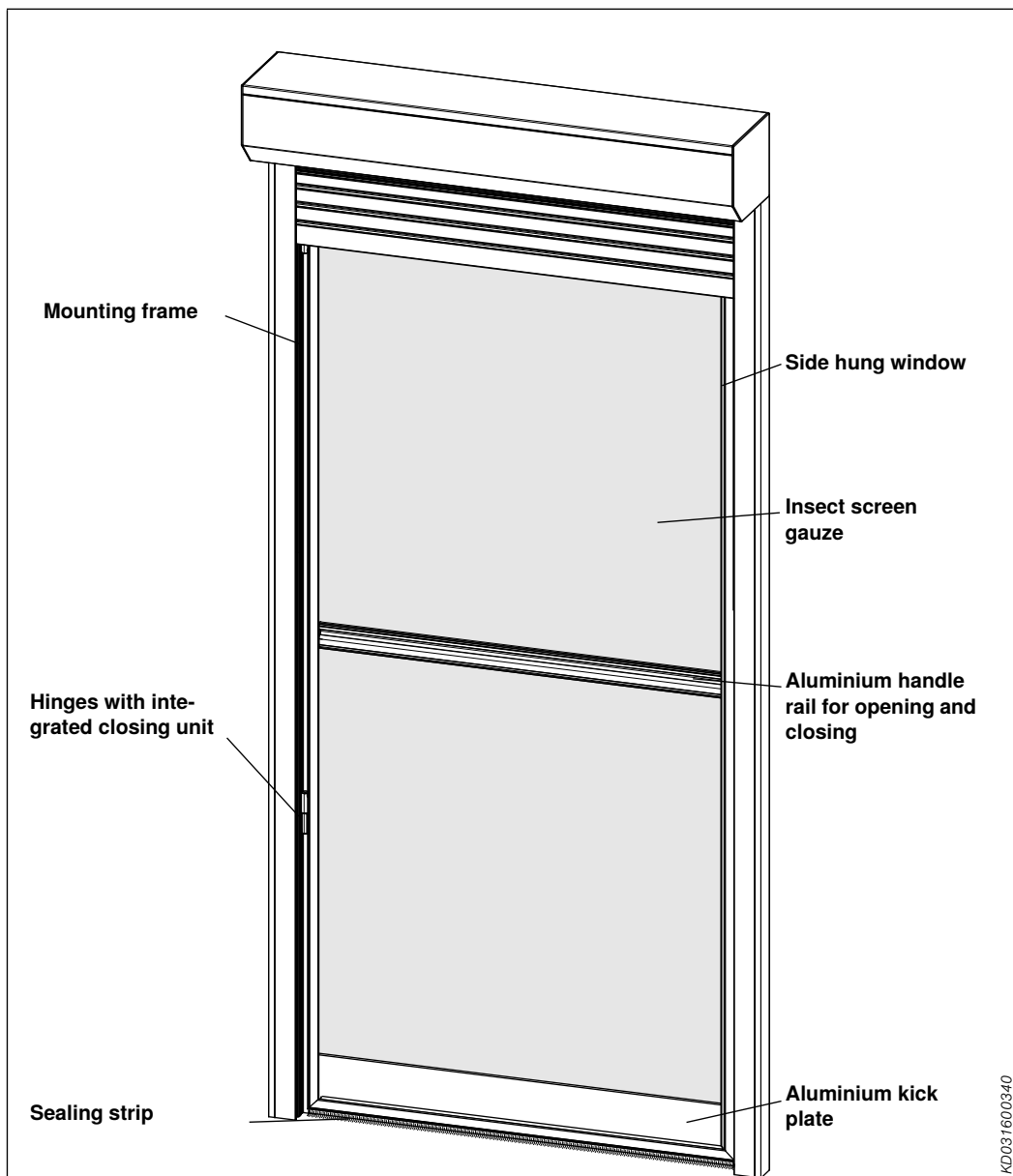

Type matrix





				
V4	○	○	○	○
V6	○	○	○	○
V10	○	○	○	○

Fig. 34: Front-mounted roller shutters with integrated insect screen roller blind

KD031600340

Front-mounted roller shutter with insect screen swivel frame

Construction limit values with insect screen swivel frame

(component dimensions front-mounted roller shutters V4/V6/V10)

V4-V10	Width in mm		Height in mm		Surface area in m ²
	min.	max.	min.	max.	
one-wing	500	1300	700	2700	2.7
two-wing	1000	2600	700	2700	5.4

V6 Round with insect screen swivel frame – one-wing model

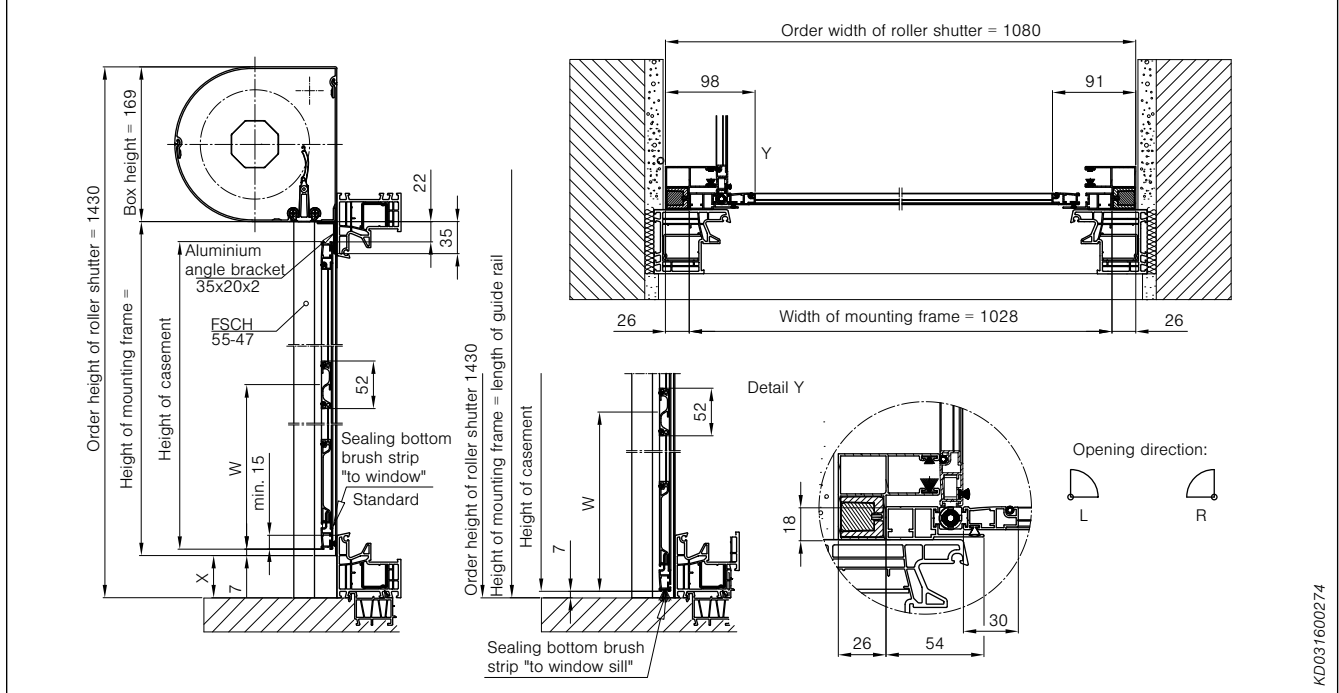

KD031600274

Fig. 35: Insect screen swivel frame standard 1 casement available for V4/V6/V10

V6 Round with insect screen swivel frame – two-wing model

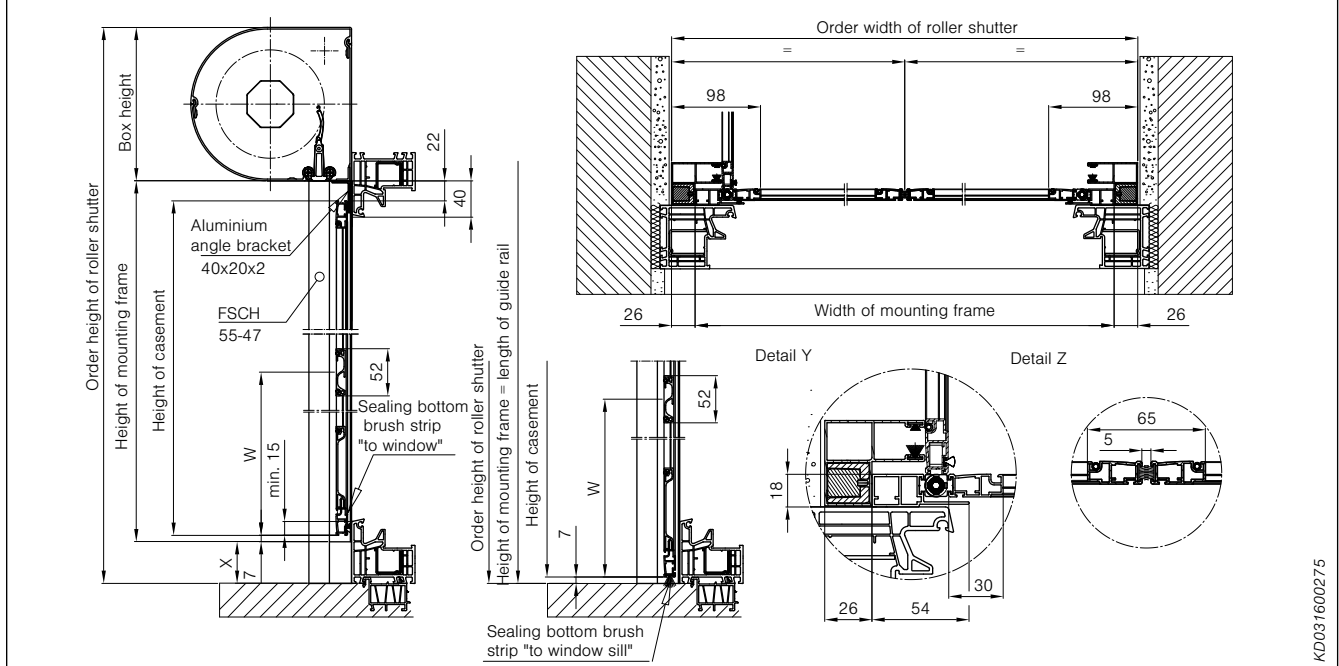

KD031600275

Fig. 36: Insect screen swivel frame standard 2 casement available for V4/V6/V10

Determining dimensions/order data

Front-mounted roller shutter with insect screen swivel frame

For standard scope of delivery and construction limit values see page 76 f.

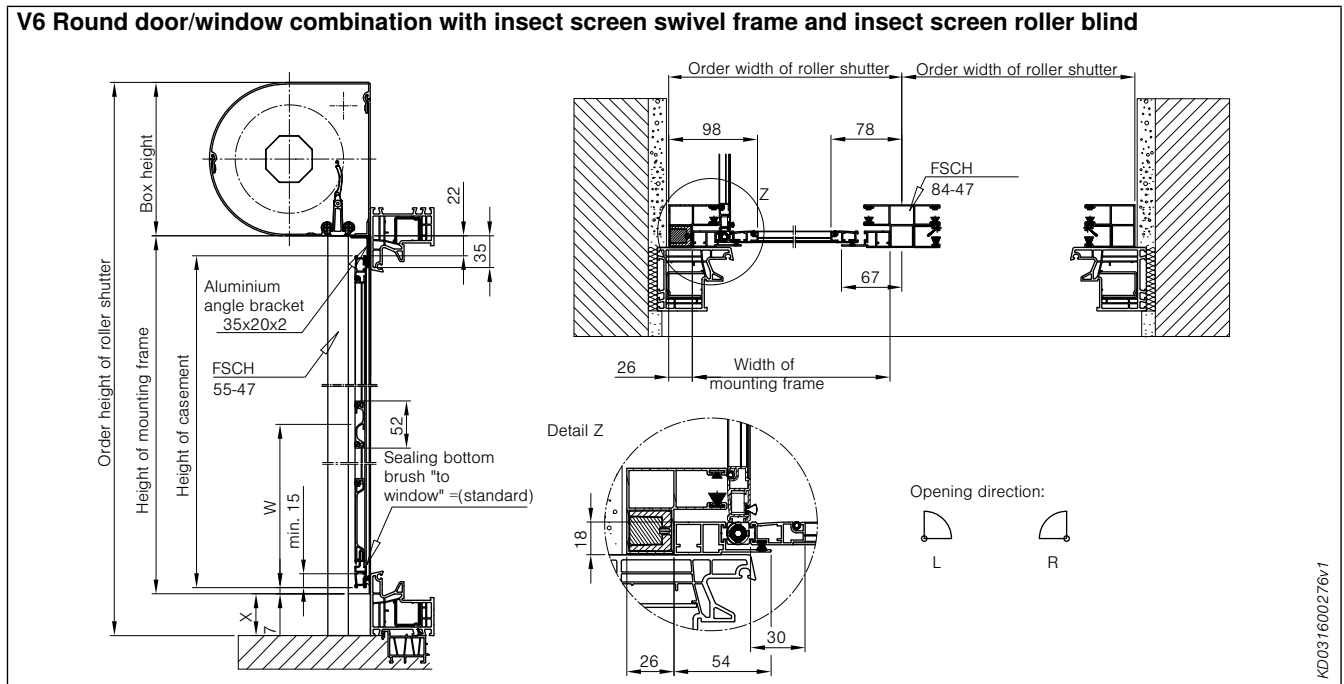

Fig. 37: Insect screen swivel frame together with door/window combination available for V4/V6/V10

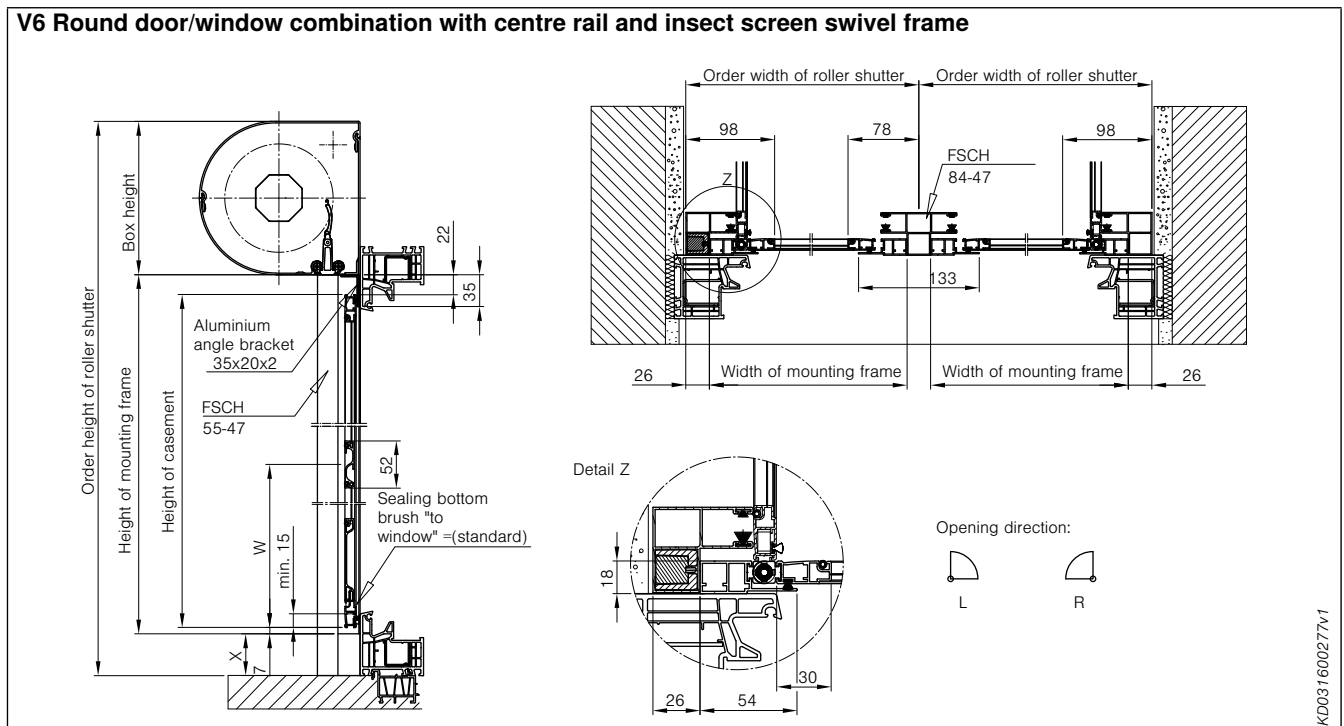

Fig. 38: Insect screen swivel frame V4/V6/V10 available

Determining dimensions/order data

Front-mounted roller shutter with Minimax guide rails and insect screen swivel frame

Standard scope of delivery for insect screen swivel frame:

- see page 76
- If Minimax guide rails are used with furring profile instead of mounting frame

Type matrix

V4	-	-	-	-
V6	o	o	o	o
V10	o	o	o	o

V6 Round with Minimax guide rails and insect screen swivel frame – one-wing model

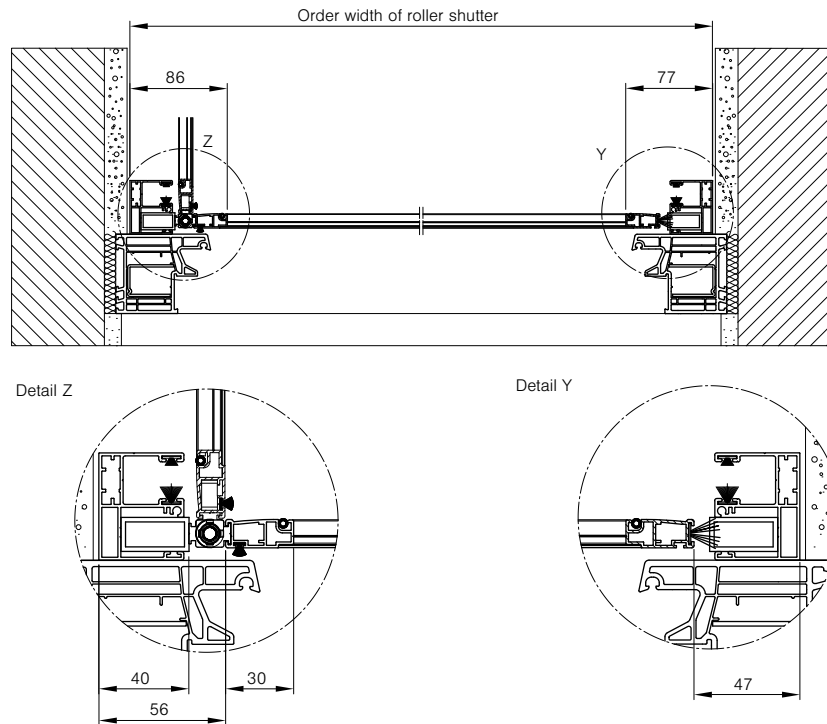

Fig. 39: Insect screen swivel frame, 1-wing model, for V6/V10 with Minimax guide rails

Determining dimensions/order data

Font-mounted roller shutter V10 solar

Notes on order data

- Note deductions measurements (see details)
- Order width = back edge of guide rails
- Order height = bottom edge of guide rail to top edge of box
- Please state side of the solar panel, seen from the inside (the motor is always on the opposite side)
- State box size if not standard (see construction limit values)

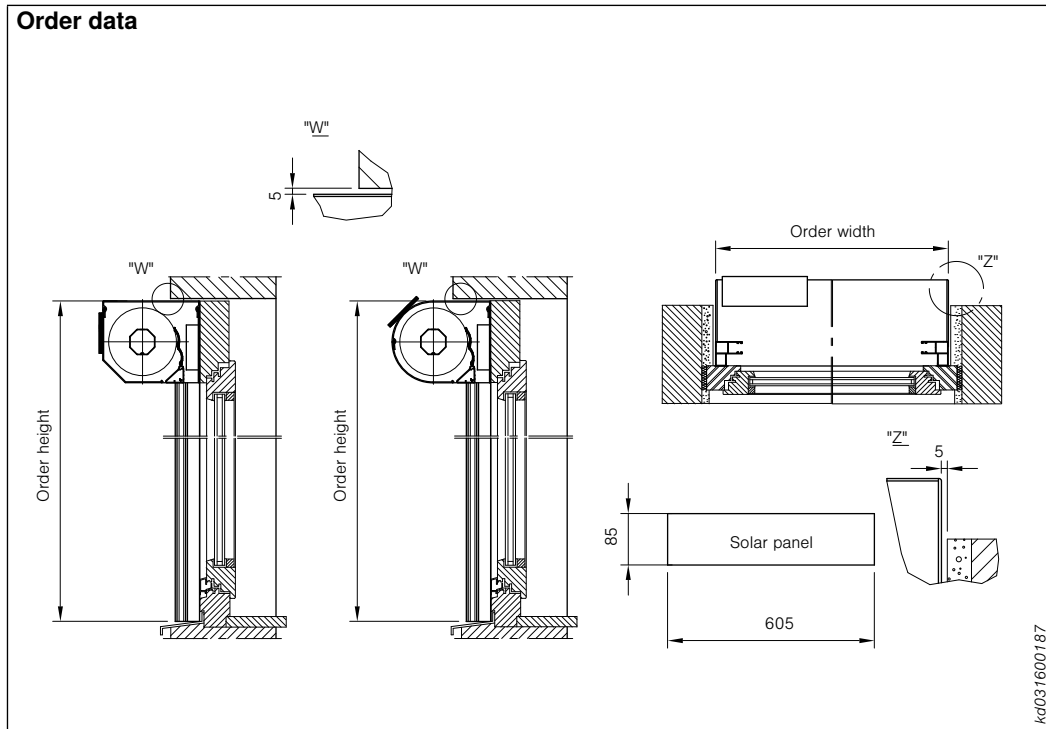

Type matrix

V4	-	-	-	-
V6	-	-	-	-
V10	o	o	o	-

Fig. 40: Order data

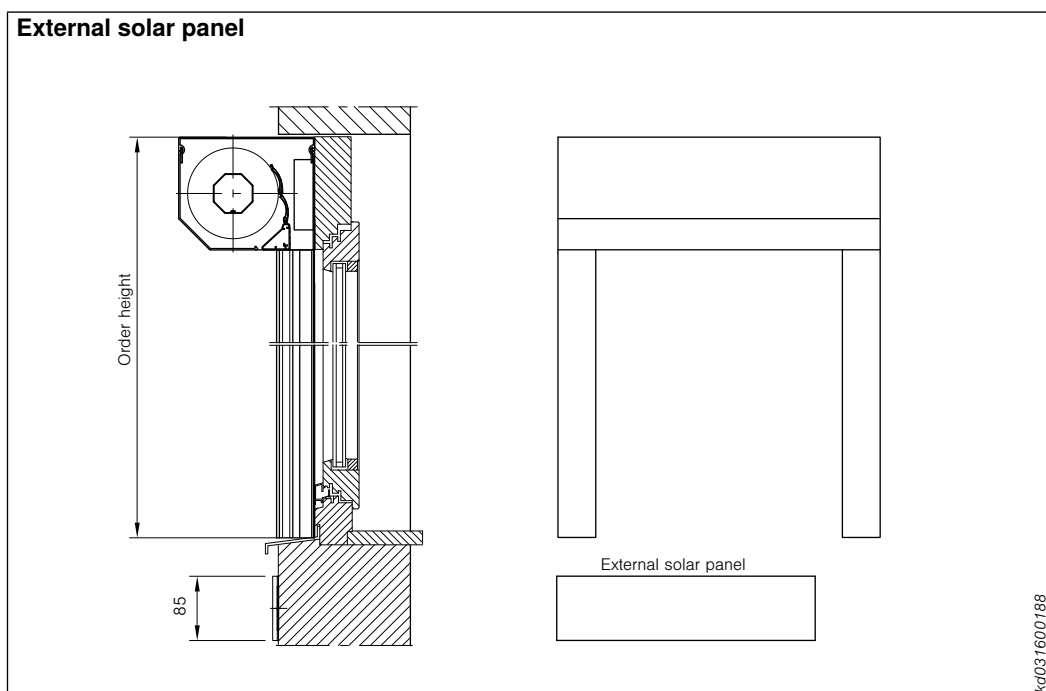

Type matrix

V4	-	-	-	-
V6	-	-	-	-
V10	o	o	o	o

Fig. 41: External solar panel

Determining dimensions/order data for combinations

Front-mounted roller shutters V4/V6

Notes for combinations:

- Order data always from left to right
- Please indicate on the order form:
2-part systems: **A** start position – **E** end position
3-part systems: **A** start position – **M** centre position – **E** end position
- Continuous box:
- folded, closed on 4 sides and extruded, closed on 3 sides up to 3000 mm width
- Extruded, closed on 4 sides up to 6000 mm width

Notes on coupling:

- A maximum of 3 units can be coupled, please note maximum drive areas and friction (see construction limit values)
- Units with different ordering heights cannot be coupled
- Centre drives (i.e. for both sides) available for centre rail size 75, 92, 101, and 110
- For centre rail size 84 and 85 only one centre drive possible
- For centre rail size 66 and 67 no centre drive possible
- On coupled units no centre drive possible

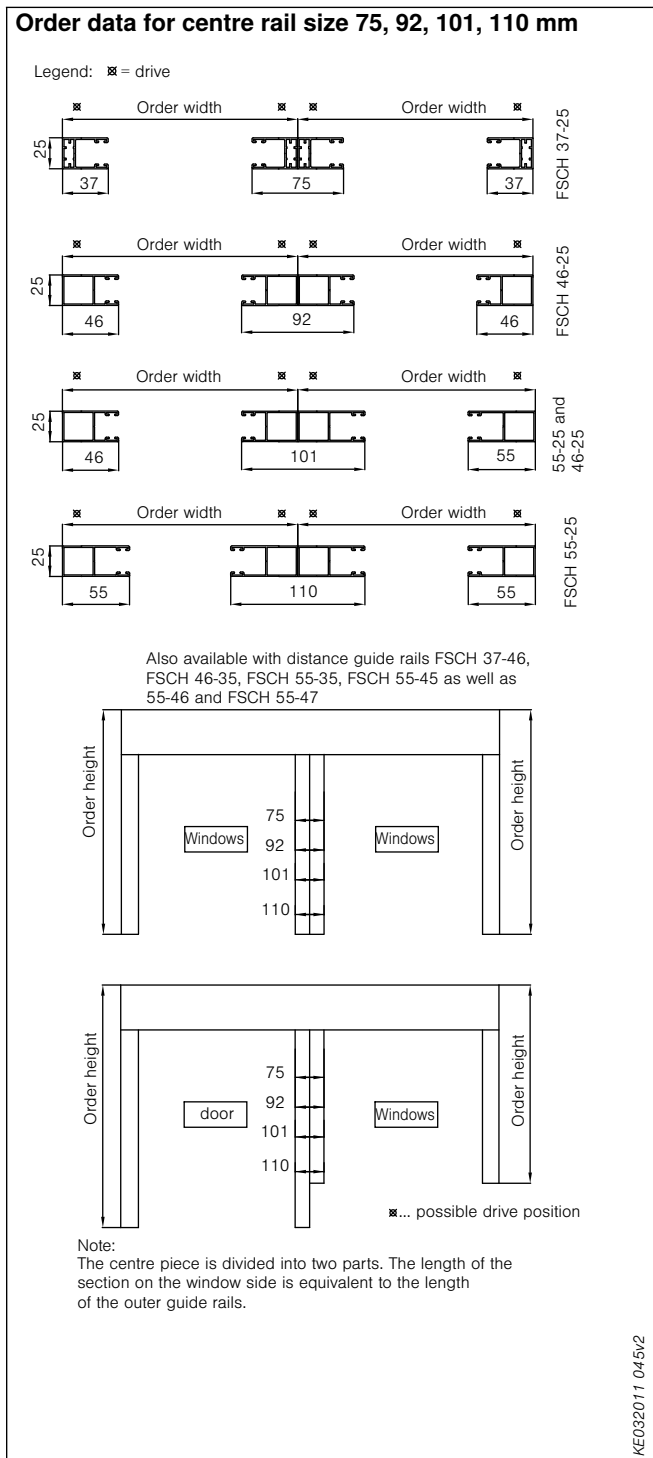

Fig. 42: Centre rail size 92, 101, 110

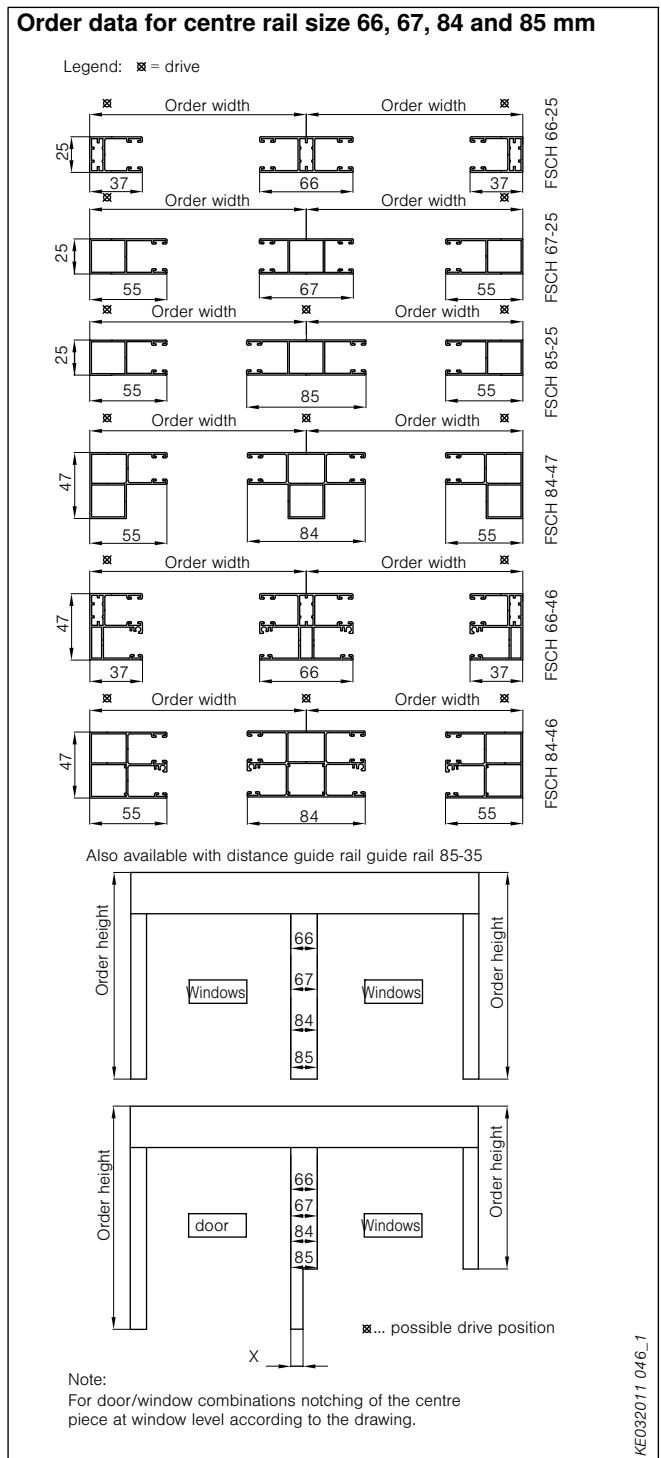

Fig. 43: Centre rail size 67, 85

Determining dimensions/order data for combinations

Front-mounted roller shutters V10

Notes for combinations:

- Order data always from left to right
- Please indicate on the order form:
2-part systems: **A** start position – **E** end position
3-part systems: **A** start position – **M** centre position – **E** end position

Notes on coupling:

- A maximum of 3 units can be coupled, please note maximum drive areas and friction (see construction limit values)
- Units with different ordering heights cannot be coupled
- Centre drives available for centre rail 110 mm
- For centre rail size 85 only one centre drive possible
- On coupled units no centre drive possible
- For centre rail size 85 no right centre drive possible

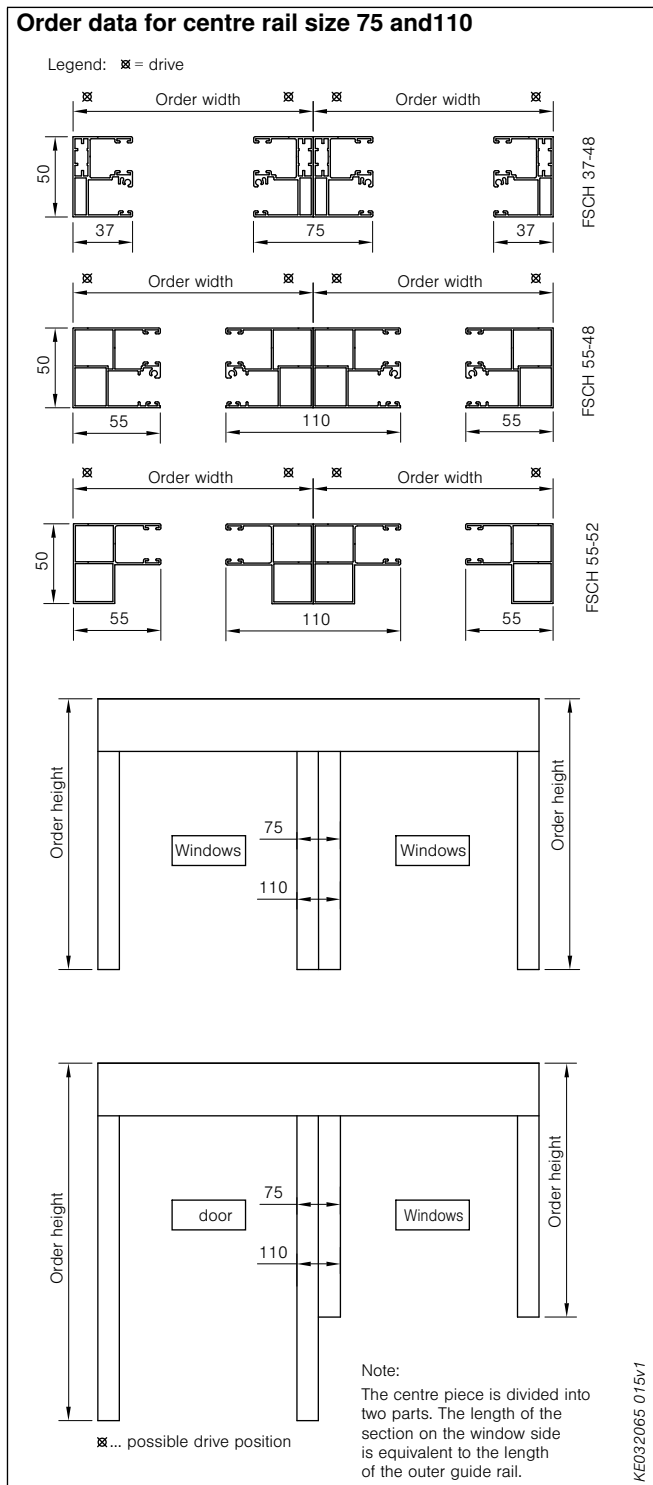

Fig. 44: Centre rail size 110

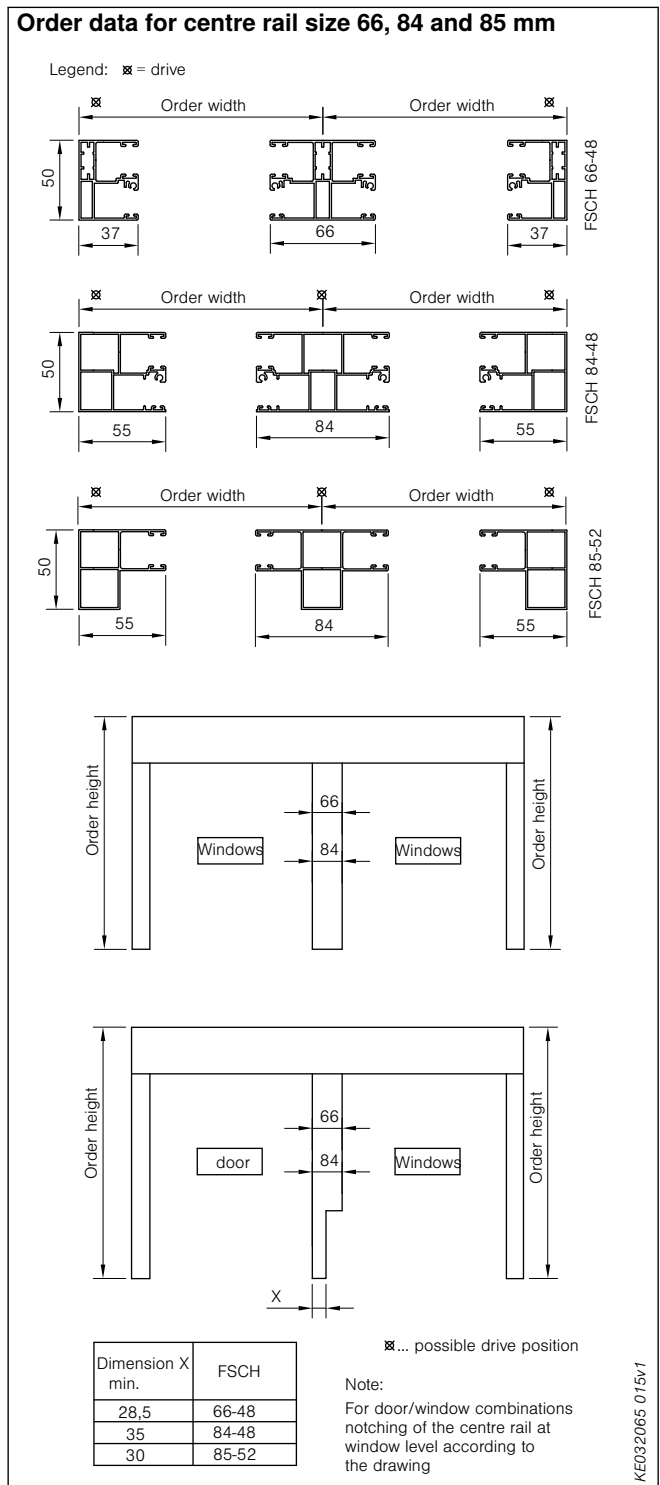

Fig. 45: Centre rail size 85

Control systems	Accessories Roller shutter curtains	Front-mounted external Venetian blinds	Security roller shutters	Guide and end rails	Additional options	Determining dimensions/operating details	Front-mounted roller shutters V10	Front-mounted roller shutters V6	Front-mounted roller shutters V4	Overview
-----------------	--	--	--------------------------	---------------------	--------------------	---	--------------------------------------	-------------------------------------	-------------------------------------	----------

Details of belt operation

Front-mounted roller shutters

General information for belt

- Horizontal belt outlet = standard
- from box size 14.5 a 90° outlet (vertical) is available on request
- Details also valid for 2:1 step-up gears, only available from box size 14.5 (16.5 for round box shape)
- Crank winder not available with step-up gear

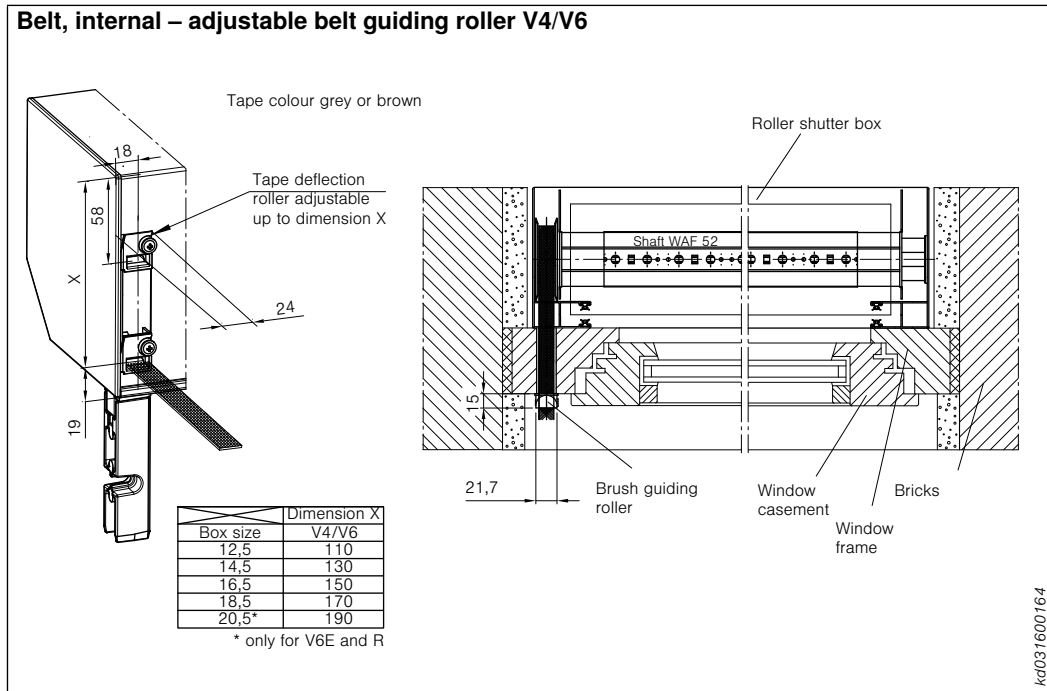
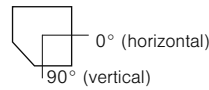

Operation

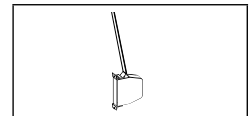

Type matrix

V4	○	○	○	○
V6	●	●	●	●

Fig. 46: Belt, internal – adjustable belt guiding roller V4/V6

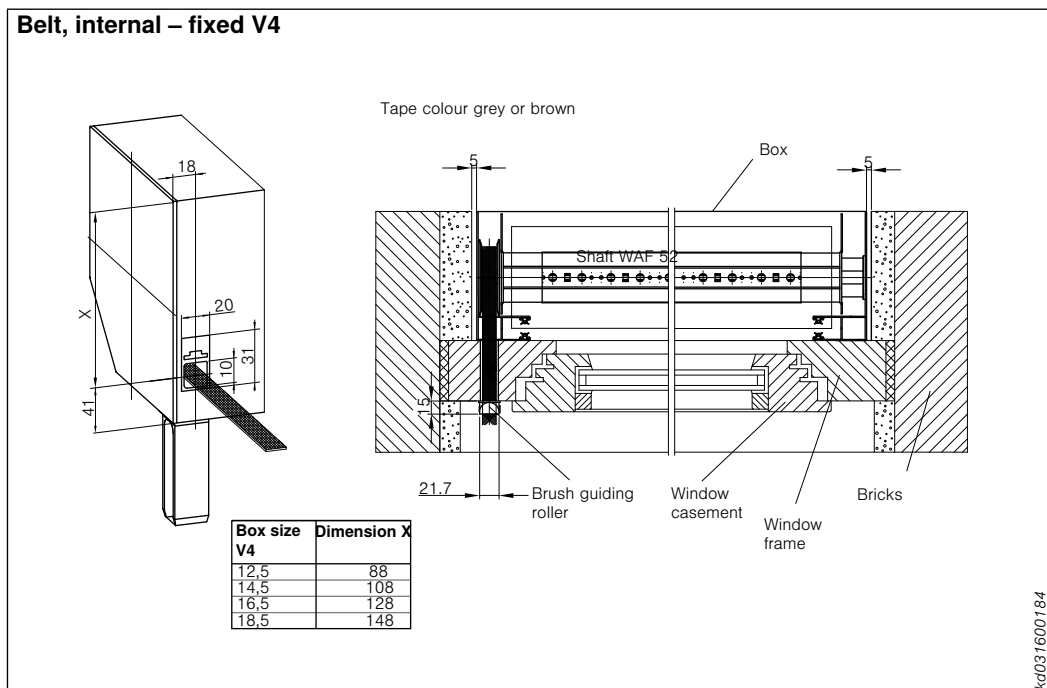

Operation

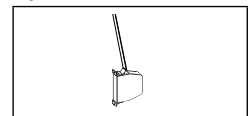

Type matrix

V4	●	●	●	●
V6	-	-	-	-

Fig. 47: Belt, internal – fixed V4

Details of belt operation

Front-mounted roller shutters

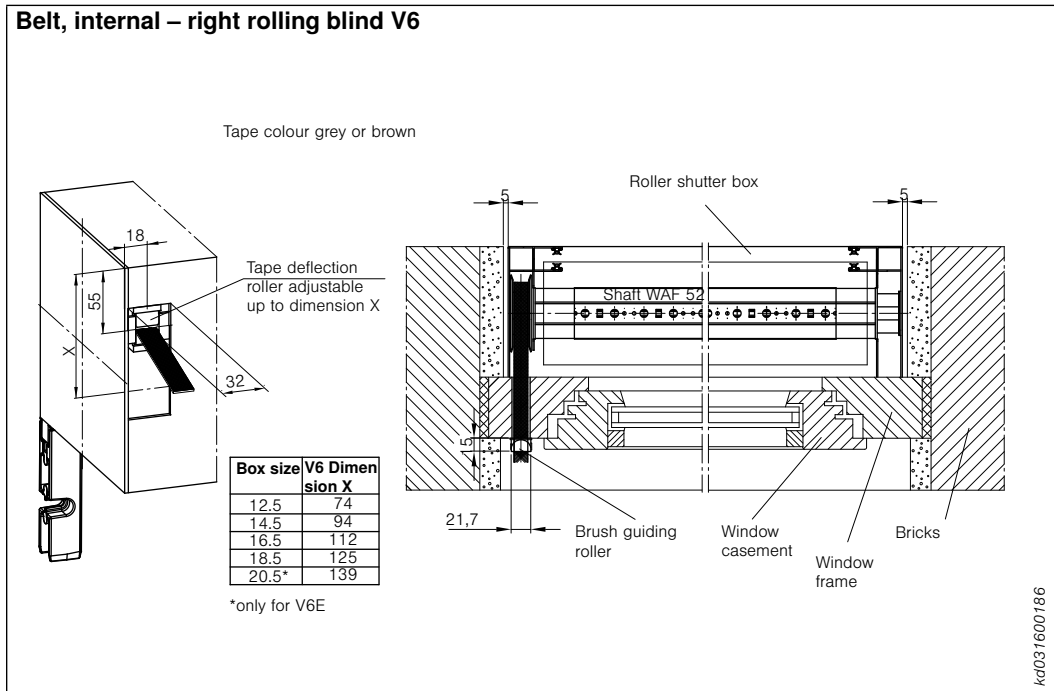
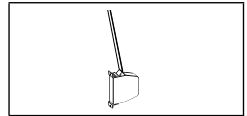

Fig. 48: Belt, internal – right rolling blind V6

Operation



Type matrix

V4	-	-	-	-
V6	o	-	o	-

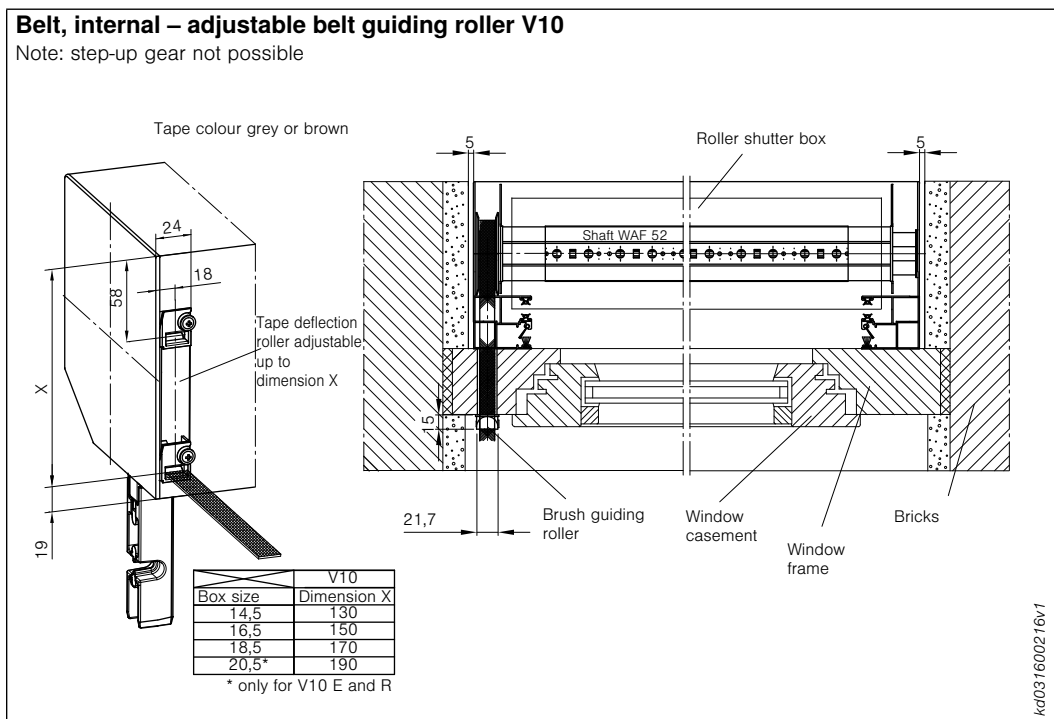
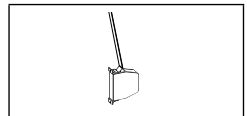

Fig. 49: Belt, internal – adjustable belt guiding roller V10

Operation



Type matrix

V10	•	•	•	•

Details of belt operation

Front-mounted roller shutters

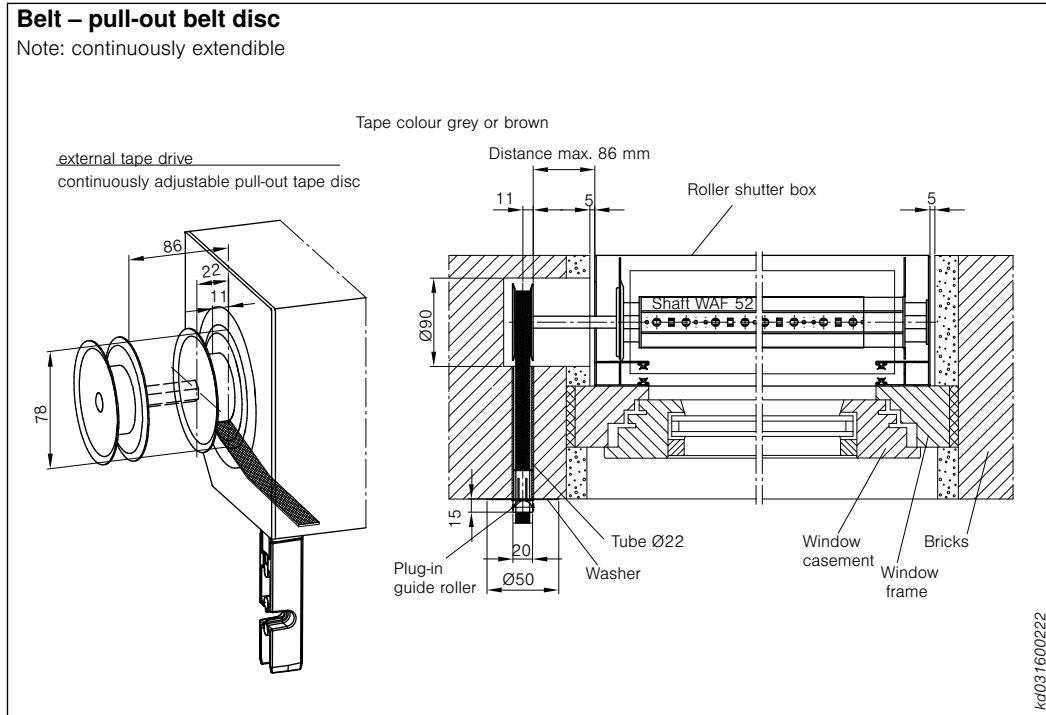

Operation

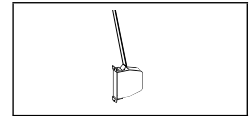

Type matrix

V4	○	○	○	-
V6	○	○	○	-
V10	○	○	○	-

Fig. 50: Belt – pull-out belt disc

Details of belt operation

Front-mounted roller shutters

General information for belt deflection:

- Belt width 14 mm
- Belt outlet, fixed (dimension x)
- Step-up gear and crank winder not available.
- The guide rails must not be embedded in plaster when using belt deflection (inspection).

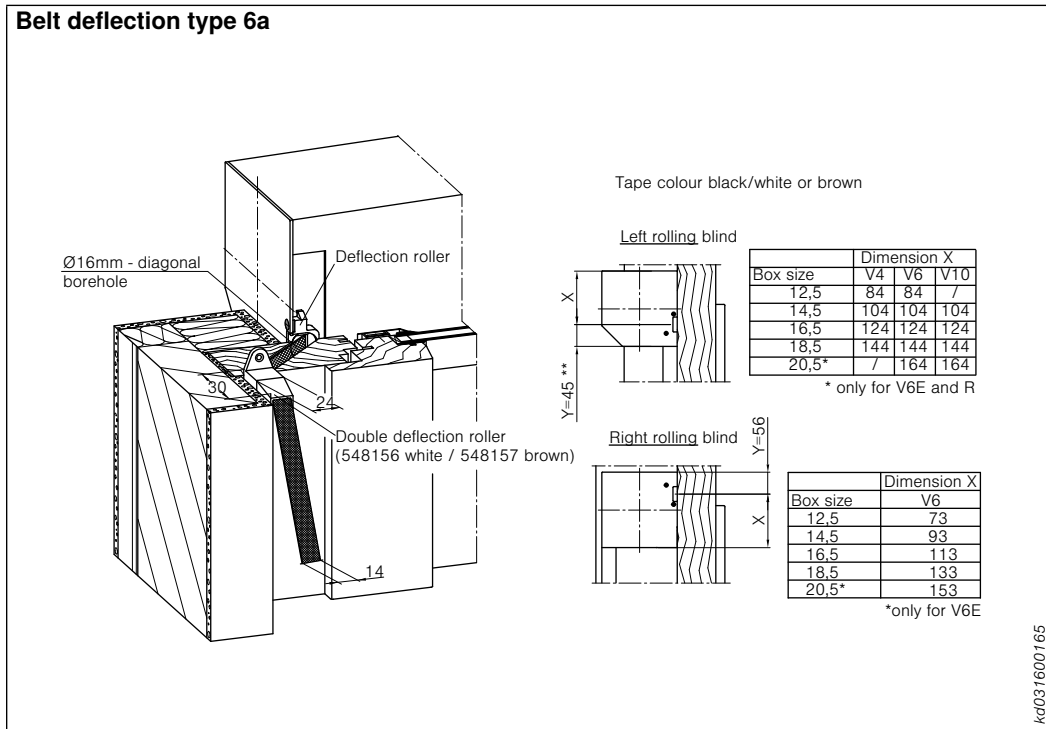

Fig. 51: Belt deflection type 6a

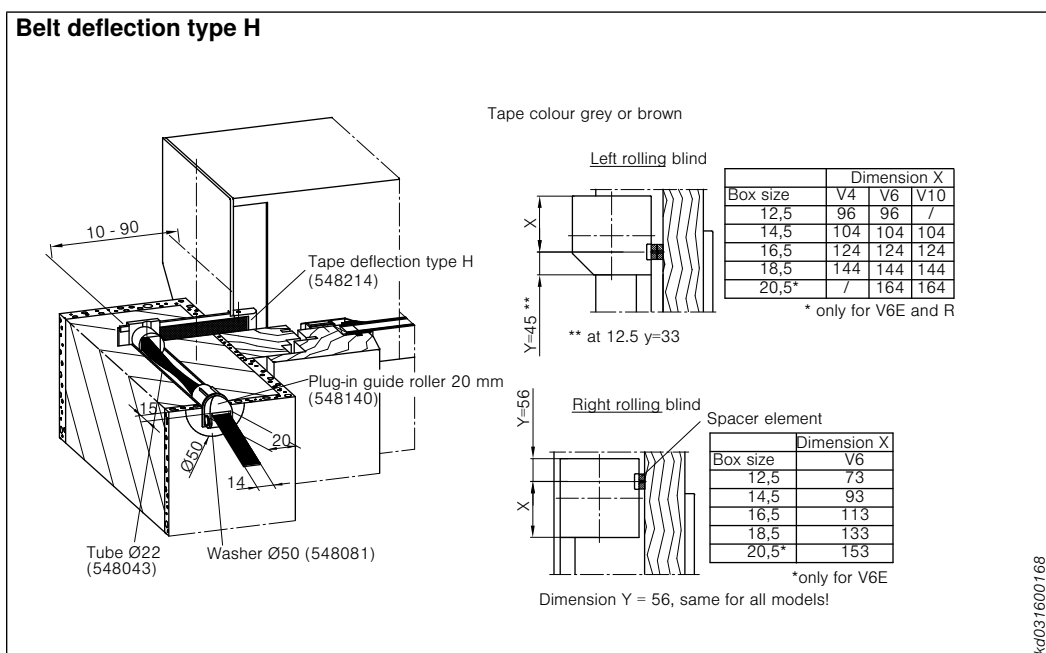
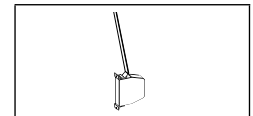

Fig. 52: Belt deflection type H

Operation



Type matrix

V4	○	○	○	-
V6	○	○	○	-
V10	○	○	○	-

Operation

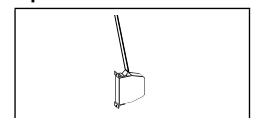

Type matrix

V4	○	○	○	-
V6	○	○	○	-
V10	○	○	○	-

Details of belt/cord operation with crank winder

Front-mounted roller shutters

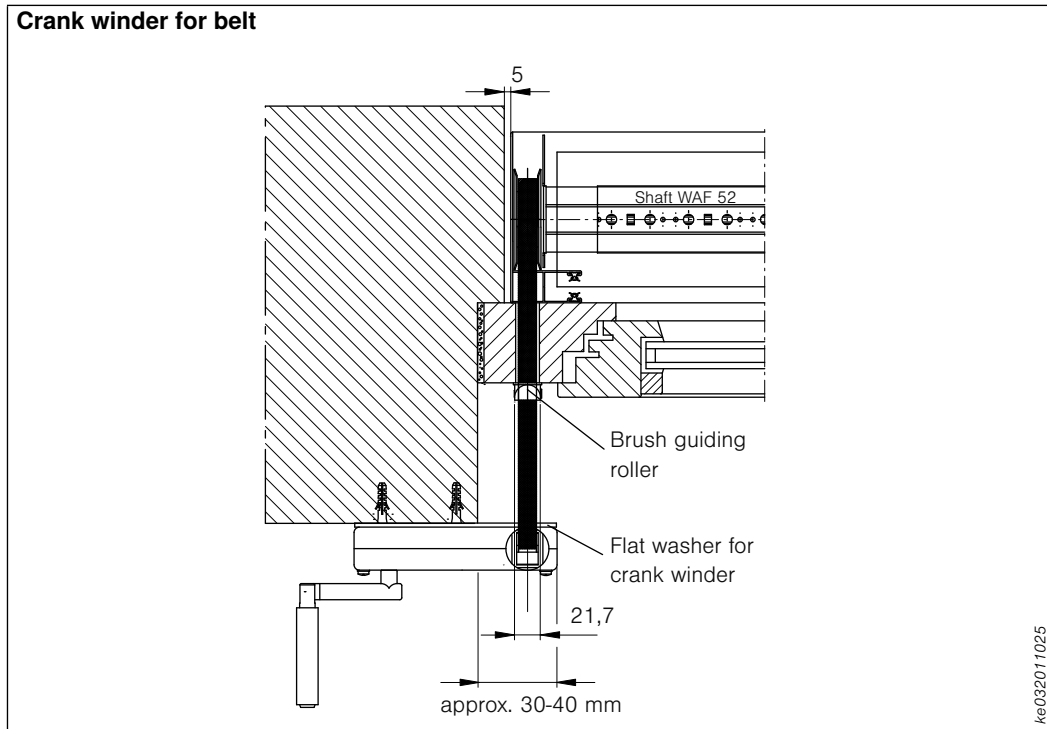

Operation

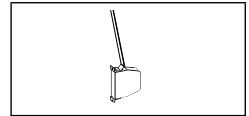

Type matrix

V4	○	○	○	○
V6	○	○	○	○
V10	○	○	○	○

Fig. 53: Crank winder for belt

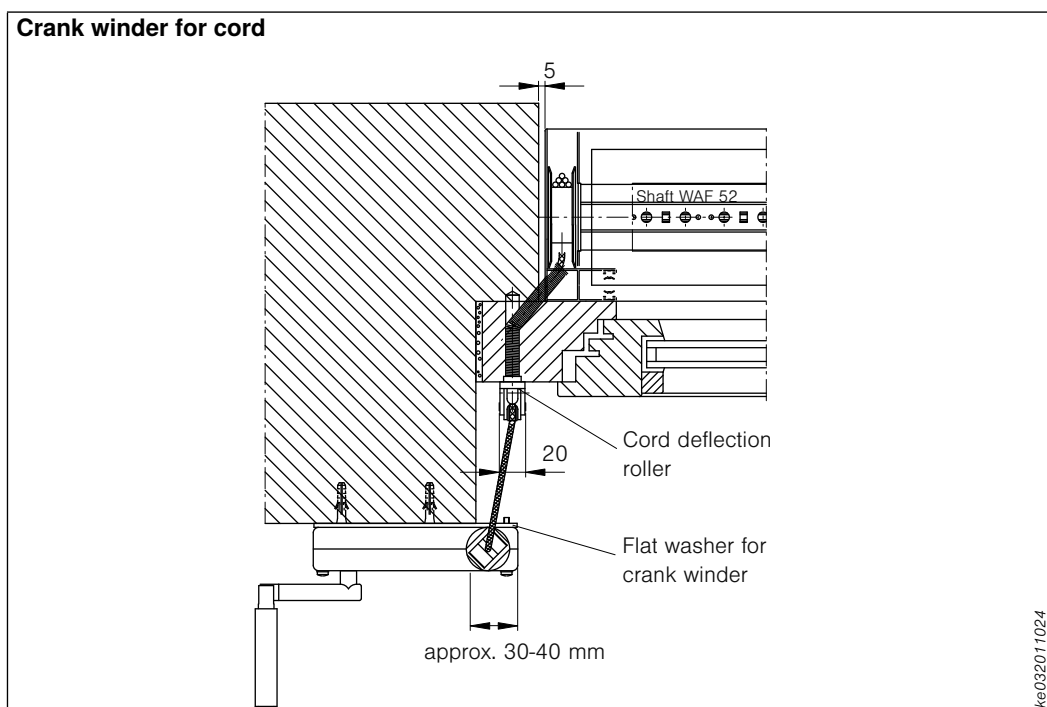

Operation

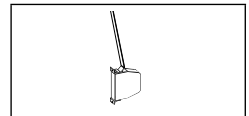

Type matrix

V4	○	○	○	○
V6	○	○	○	○
V10	○	○	○	○

Fig. 54: Crank winder for cord

Cord operation details

Front-mounted roller shutters

Note for cords

- Without pulling aid, please order separately if necessary (see accessories)

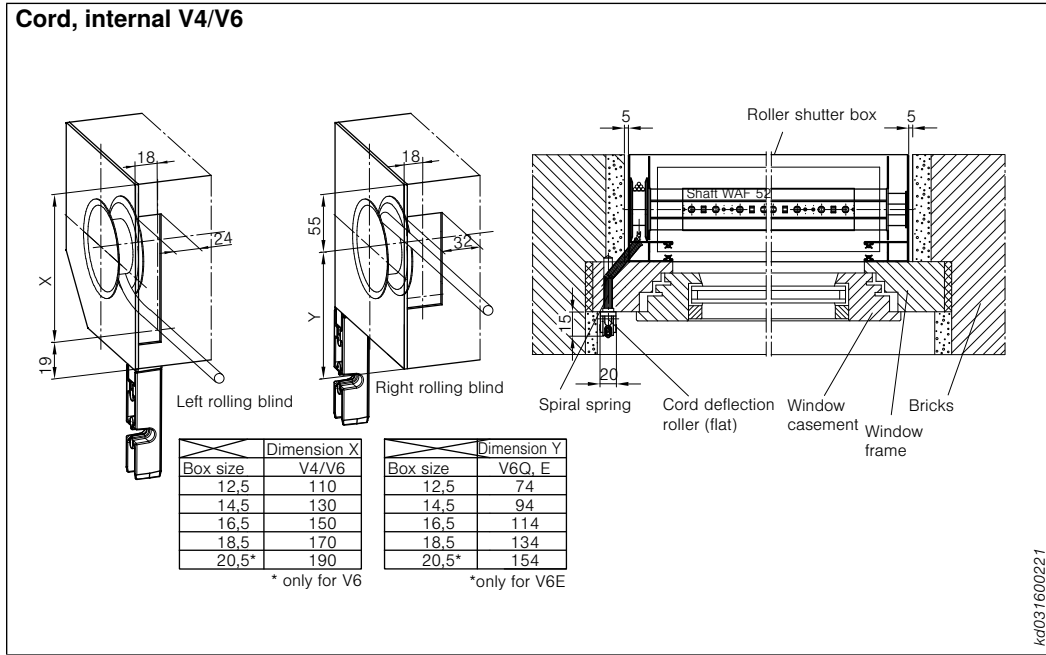

Fig. 55: Cord, internal V4/V6

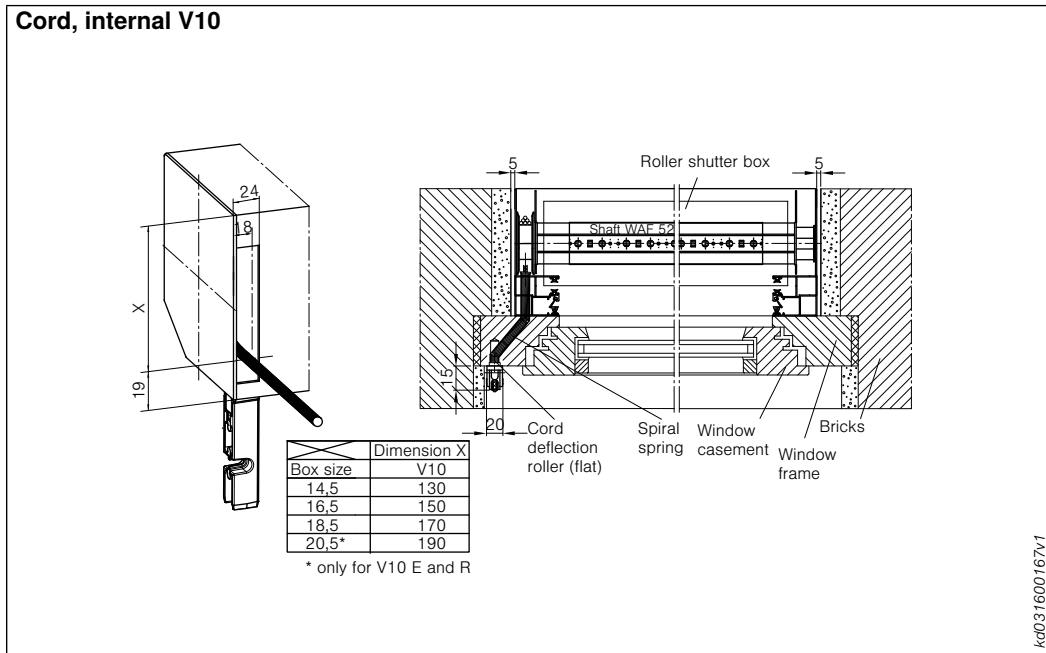
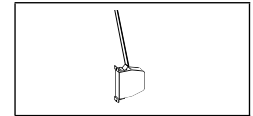

Fig. 56: Cord, internal V10

Operation



Type matrix

V4	○	○	○	○
V6	○	○	○	○

Operation

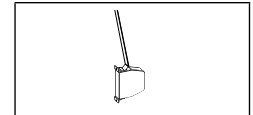

Type matrix

V10	○	○	○	○

Crank operation details

Front-mounted roller shutters

Notes for crank:

- Standard crank length 1200 mm, please specify if different (see Accessories for determination of length)
- Crank rod with collapsible crank; sealed joint plate and square with thermal separation.
- Horizontal gear outlet = standard
- from box size 14.5 a 90° outlet (vertical) is available on request

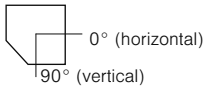

Crank, internal – left rolling blind V4/V6/V10

Internal crank drive type 1 Internal crank drive type 2

Gear outlet: square WAF 6mm Roller shutter box

Shaft WAF 52

Pivot bearing Window casement Bricks Window frame

Crank type 1 Crank type 2

Outlet angle for V4/V6 with crank type 1

Box size	Dimension X for W max.	W min.	W max.
12.5	90	0°	43°
14.5	110	0°	49°
16.5	129	0°	48°
18.5	148	0°	48°
20.5 x	168	0°	47°

* only for V6E and R

Outlet angle for V4/V6 with crank type 2

Box size	Dimension X for W max.	W min.	W max.
12.5	103	0°	29°
14.5	122	0°	32°
16.5	142	0°	33°
18.5	164	0°	35°
20.5 x	182	0°	36°

* only for V6E and R

Outlet angle for V10 with crank type 1

Box size	Dimension X for W max.	W min.	W max.
14.5	71	0°	40°
16.5	91	0°	40°
18.5*	111	0°	40°
20.5**	131	0°	41°

* only for V10
** only for V10 E and R

Outlet angle for V10 with crank type 2

Box size	Dimension X for W max.	W min.	W max.
14.5	124	0°	25°
16.5	143	0°	27°
18.5	162	0°	29°
20.5 x	181	0°	30°

* only for V10 E and R

KD031600337

Operation

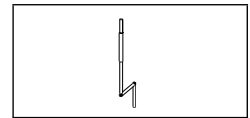

Type matrix

V4	●	●	●	●
V6	●	●	●	●
V10	●	●	●	●

Fig. 57: Crank, internal – left rolling blind V10

Crank operation details

Front-mounted roller shutters

Information about crank with pull-out gear:

- Standard crank length 1200 mm, please specify if different (see Accessories for determination of length)
- Crank rod with collapsible crank; sealed joint plate and square with thermal separation.
- Please note max. drive areas
- Continuously extendible

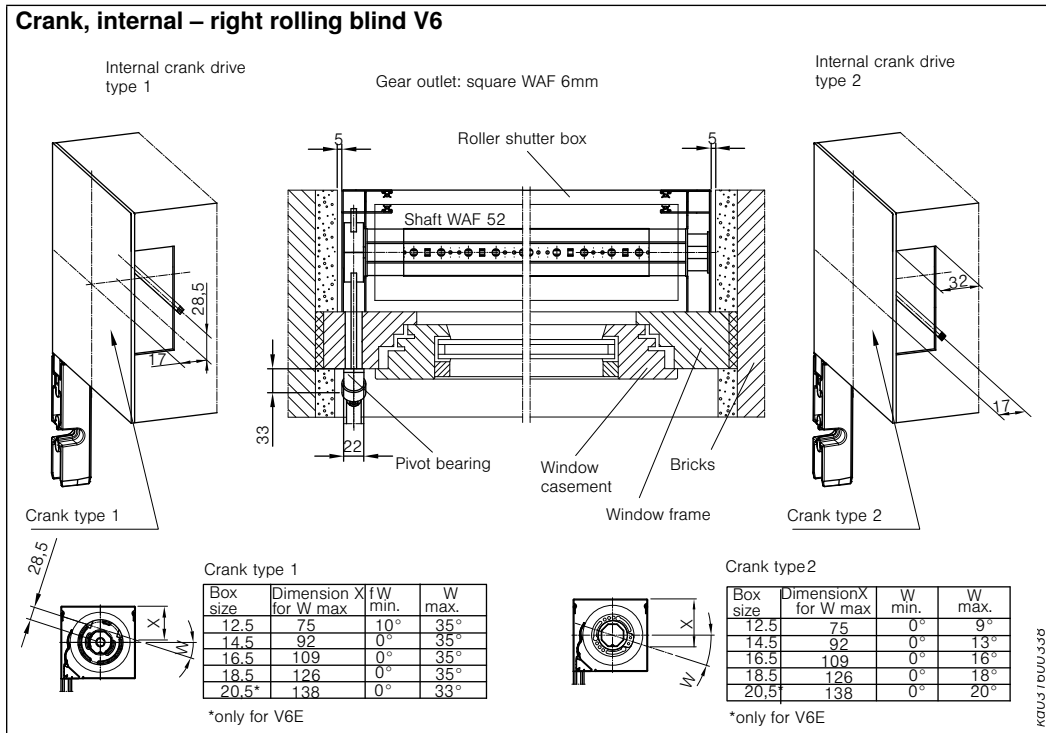
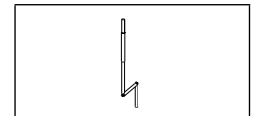

Fig. 58: Crank, internal – right rolling blind V6

Operation



Type matrix

V4	-	-	-	-
V6	o	-	o	-
V10	-	-	-	-

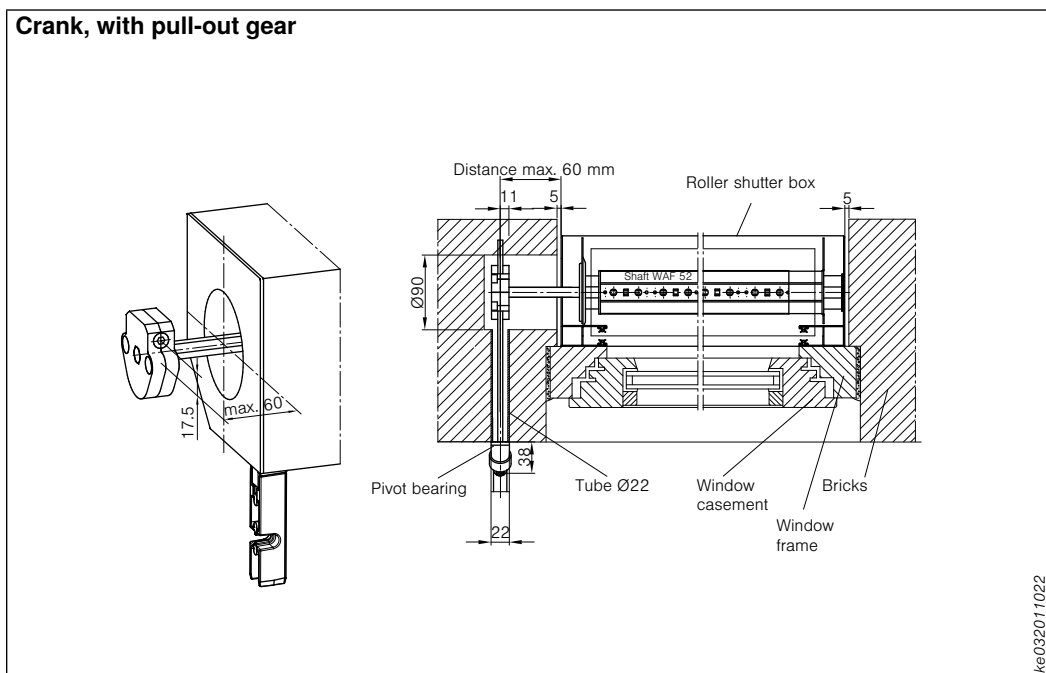
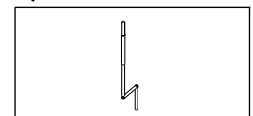

Fig. 59: Crank, with pull-out gear

Operation



Type matrix

V4	o	o	o	-
V6	o	o	o	-
V10	o	o	o	-

Motor operation details

Front-mounted roller shutters

Notes for motor:

- Standard motor cable length 1000 mm
- Special lengths 2500 mm, 5000 mm and 10000 mm, please specify in your order
- Motor cable without plug-in connector as standard, please state separately if necessary (will be supplied loose)
- Front-mounted roller shutters with motor drive can generally be commissioned with one drive cable when mounting. Making further settings for motors with torque overload protection requires a programming cable art. no. 617641).
- The model with motor with emergency crank handle (optional) makes the use of a flat end rail necessary

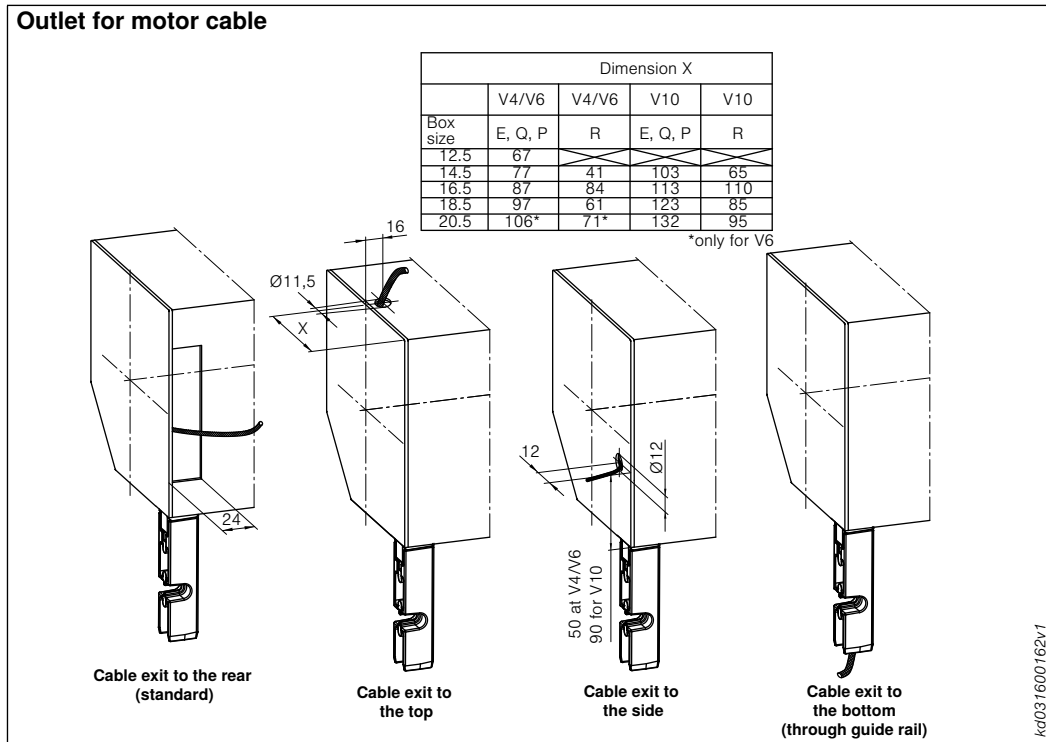

Operation

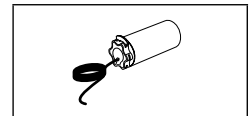

Type matrix

V4	○	○	○	○
V6	○	○	○	○
V10	○	○	○	○

Fig. 60: Outlet for motor cable

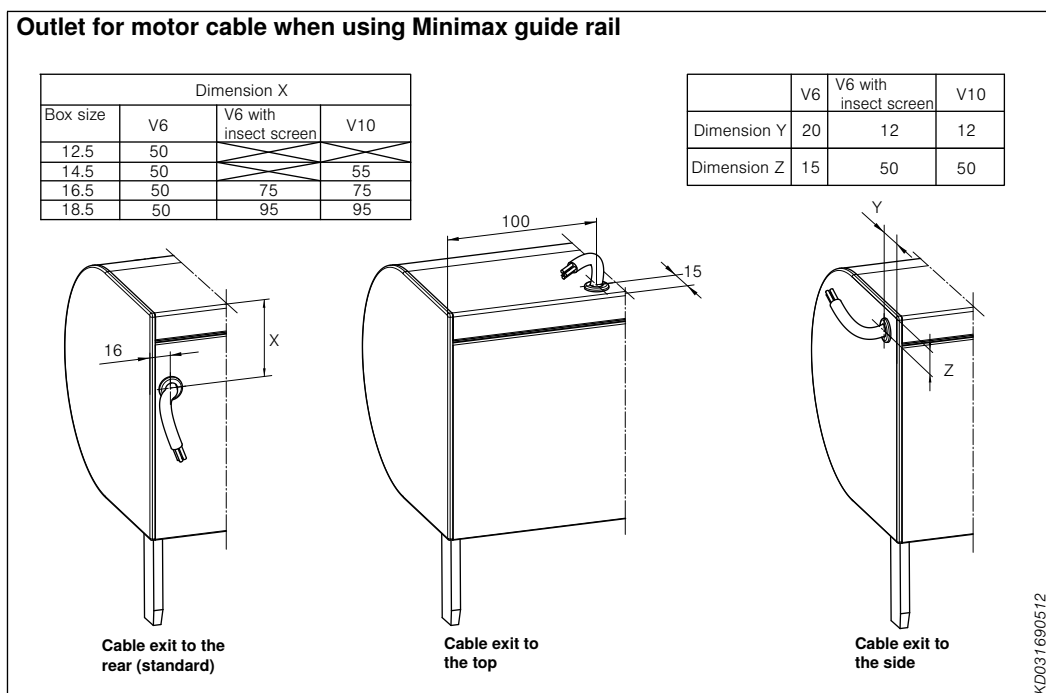

Type matrix

V4	-	-	-	-
V6	○	○	○	○
V10	○	○	○	○

Fig. 61: Outlet for motor cable when using Minimax guide rail

Contents

Supplementary accessories

Minimax guide rails	94
Security package in accordance with DIN 18073	95
Quick installation kit	96
Additional box fastening	97
Outlet gap closed for models without insect screen	98
Box extensions	99

Minimax guide rails

Front-mounted roller shutters

Minimax guide rails:

- The hollow chamber section of the guide rail is shortened, resulting in a slim visible guide rail width of only 37.5 mm
- also available with insect screen
- The time, work and expense required for the installation is identical to that of models with standard guide rails
- For illustrations of the different guide rails see page 115.

Notes:

- available for front-mounted roller shutters V6 and V10

- compatible with the box shapes rectangular, round, square and plaster with a box closed on 4 sides
- available box sizes: 14.5, 16.5 and 18.5
- left rolling model
- available only with motor operation (solar drive and motor with emergency crank handle not possible)
- in combination with the profiles A 36, A 44, K 36 and V 36
- no additional accessories available (such as quick installation kit, security package or projection arm).

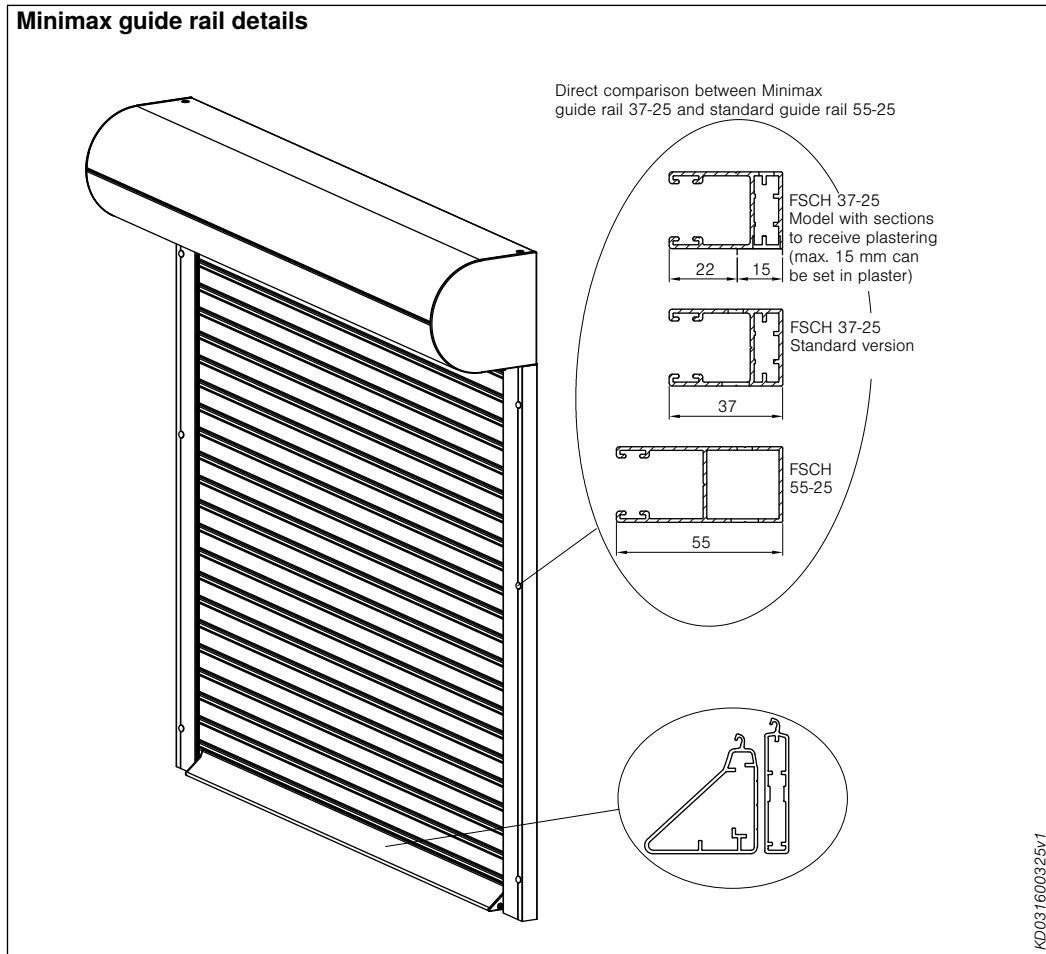

Type matrix

V4	-	-	-	-
V6	o	o	o	o
V10	o	o	o	o

Fig. 62: Minimax guide rail details

The construction limit values are identical to those of the standard guide rails, such as e.g. FSCH 55-25. Please also refer to the tables on page 49 and page 59.

Security package in accordance with DIN 18073

Front-mounted roller shutters

Security package for advanced security requirements in accordance with DIN 18073:

- Reinforced push-up guard
- Guide rails secured with aluminium bolts against dismantling from outside
- Increased lateral curtain insertion length using wider guide rails (60 mm)
- Reinforced guide rails prevent bending from the outside
- Protection against prying out the box with screw connection of adapter to guide rail
- Riveted inspection cover for increased protection against dismantling

Notes:

- For front-mounted roller shutters V6 and V10
- in combination with the aluminium profiles A 36, A 44, A 53, S 37 within wind resistance class 6
- Available with triangular design end rail or flat end rail with sliding bolt locking
- Independent of drive type, for belt, crank and motor operation (exception: S 37 – only motor operation)
- Only for boxes closed on all 4 sides

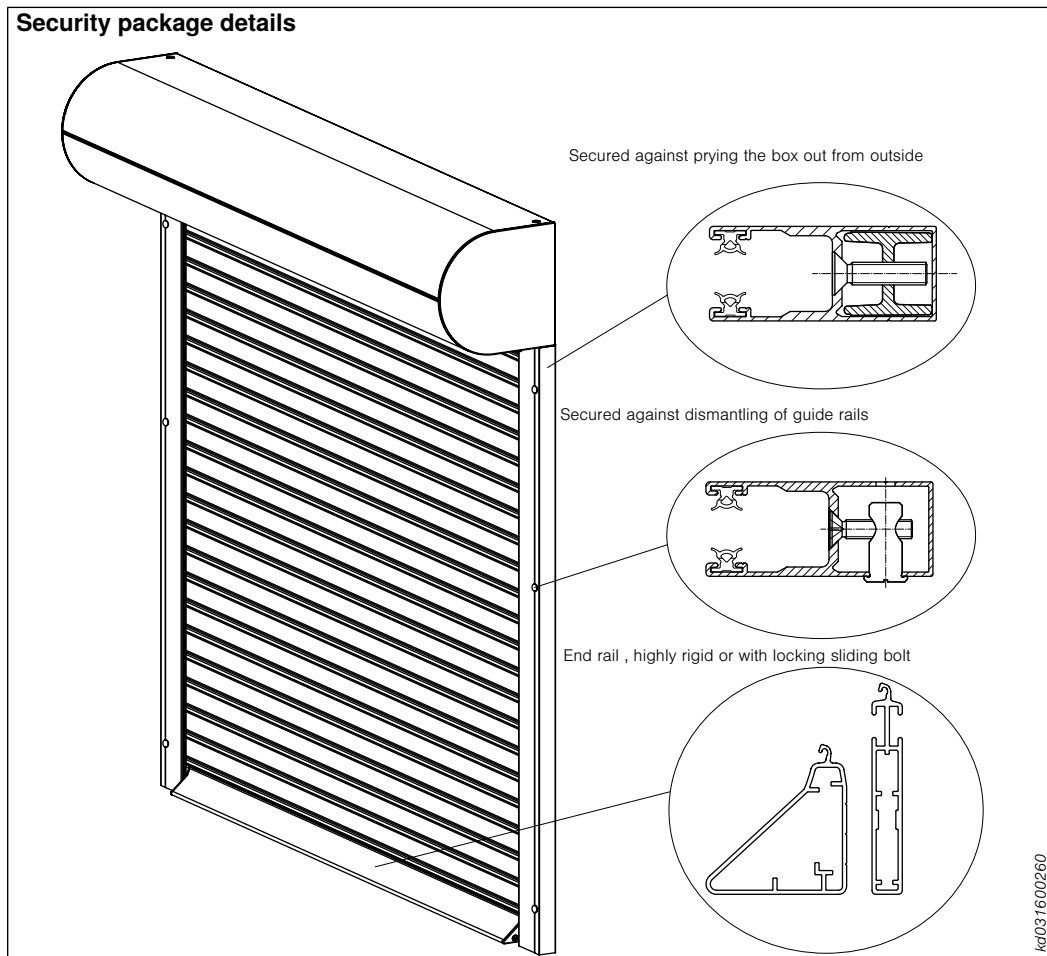

Fig. 63: Security package details

Type matrix

V4	-	-	-	-
V6	o	o	o	o
V10	o	o	o	o

Max. widths for wind resistance class 6 in mm

Roller shutter profile	Width	Guide rail
A 36	1700	60-25, 95-25, 60-47, 95-47, 60-48, 94-48
A 44	1800	60-25, 95-25, 60-48, 94-48
A 53 ¹⁾	2100	60-25, 95-25
S 37	2100	60-25, 95-25, 60-48, 94-48

¹⁾ not suitable for V10

Quick installation kit

Front-mounted roller shutters

Mounting procedure

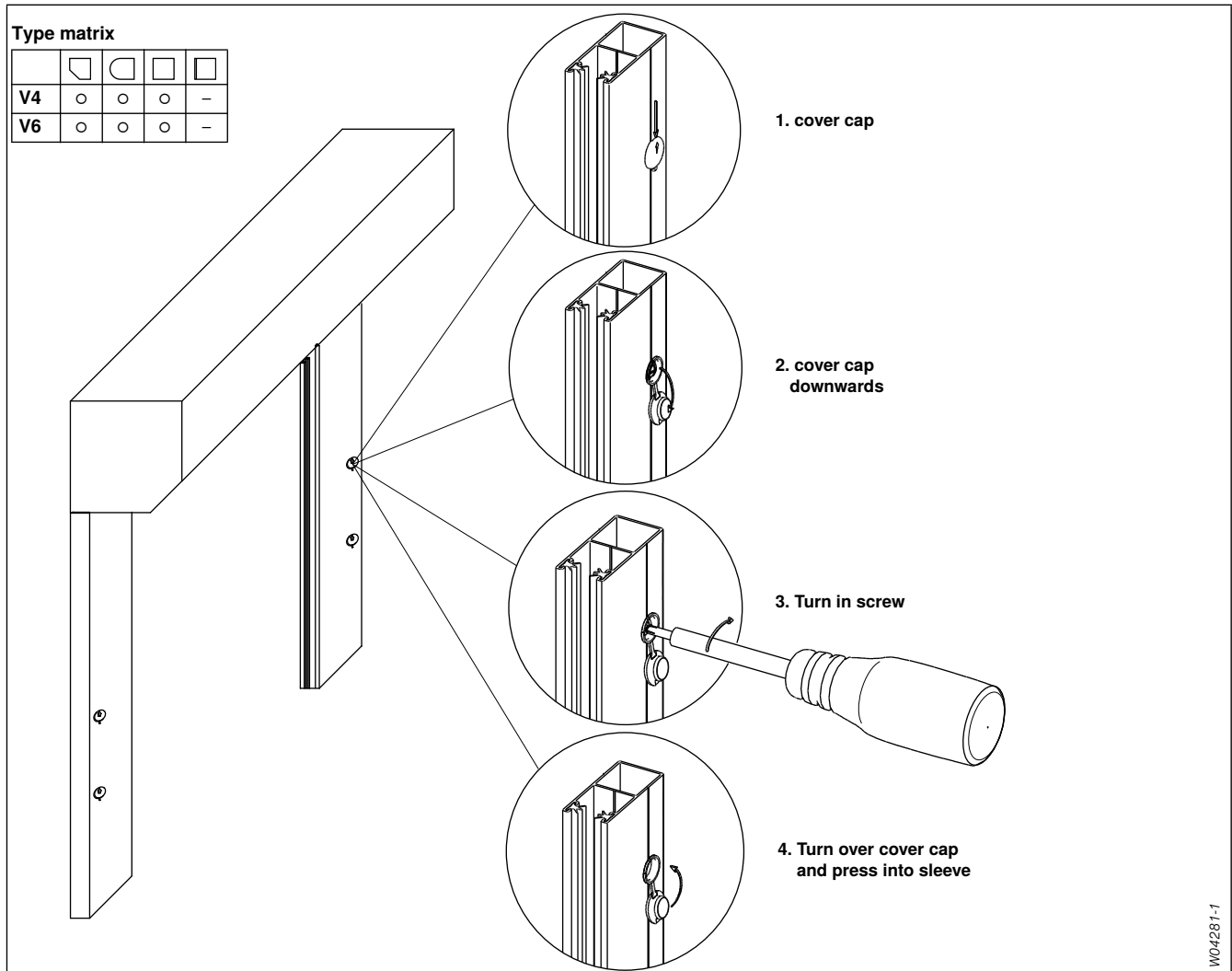

Fig. 64: Mounting procedure

Notes on quick installation kit:

- Only suitable for drilled hole 2
- Not possible in combination with guide rail drilled hole moved outwards for plaster elements
- Only for guide rails 46-25, 46-35, 55-25, 55-35, 85-25, 85-35
- Only in white, grey, brown and black.

Mounting substructure

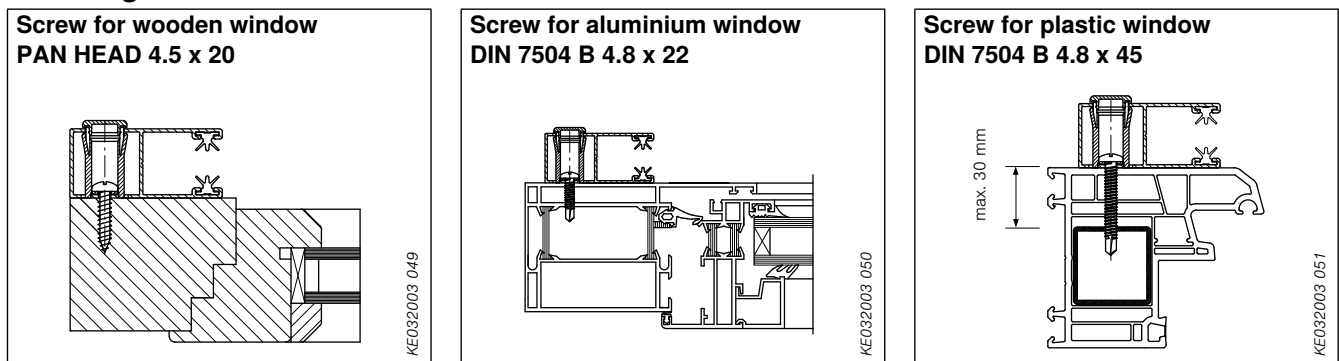

Fig. 65: Mounting substructure

Additional box fastening

Front-mounted roller shutters

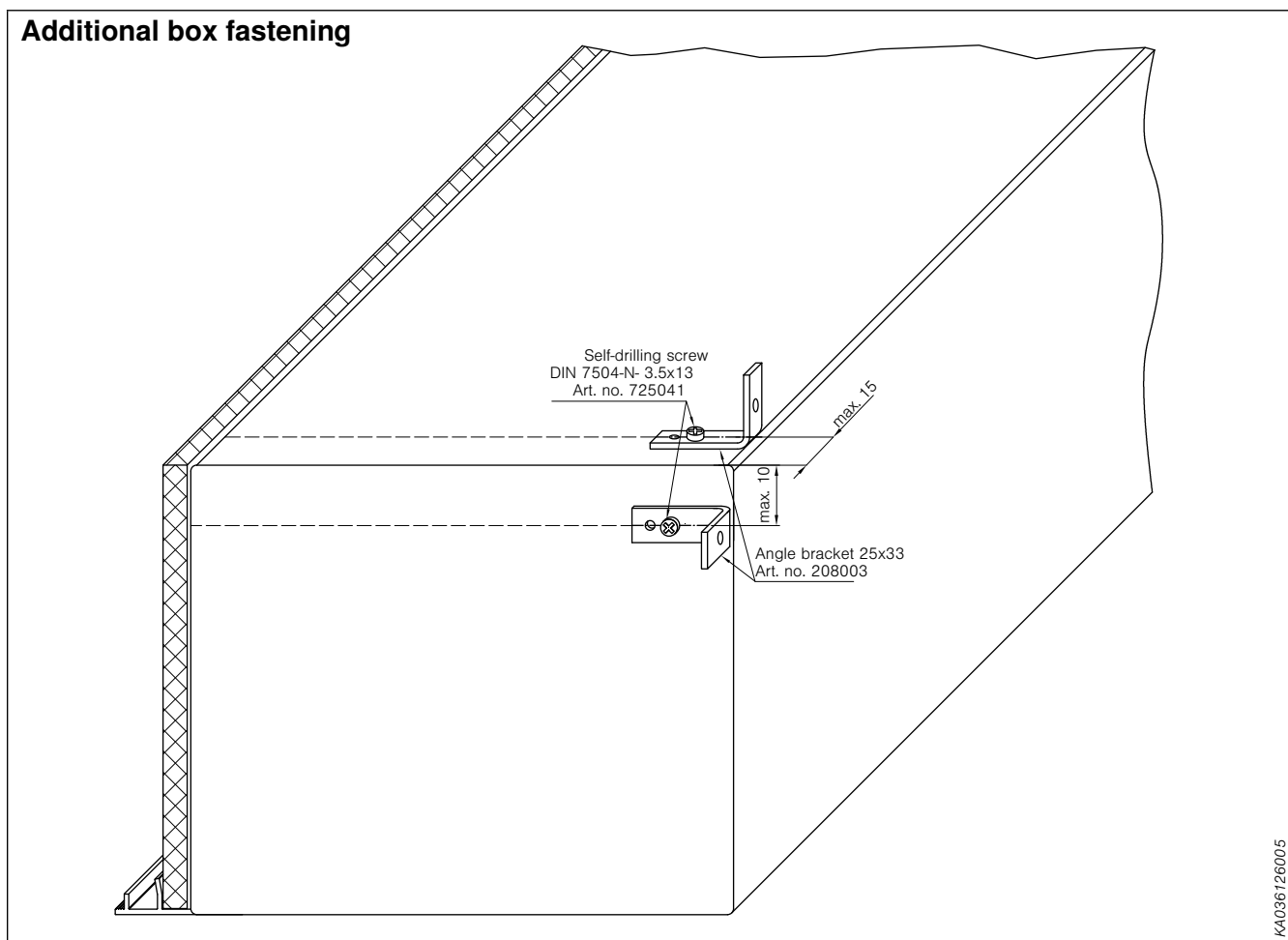

Fig. 66: Additional box fastening

From order widths of over 1500 mm we recommend additional box fastening. For models with plaster elements or for box shape plaster these angle brackets are supplied as a standard.

Scope of delivery

Angle bracket 25x33 mm, art. no. 208003.
Per bracket: 2 drilling screws DIN 7504-3,5x13, art. no. 725041

Notes:

- The fixing brackets can be positioned alternatively at the top or at the side
- Do not use any screws longer than the ones supplied
- The maximum clearances (10 and 15 mm, resp.) have to be observed
- The angle bracket can also be turned and moved along the lines shown
- Drilled hole for on-site installation 4.2 mm

Type matrix

V4	○	○	○	●
V6	○	○	○	●
V10	○	○	○	●

Legend:

- standard
- optional
- not possible

Outlet gap closed for models without insect screen

Front-mounted roller shutters

When using guide rails 55-47, 55-46, 55-48, 55-52, 37-46 and 37-48 without insect screen roller blind, the outlet gap can optionally be closed with an angle bracket.

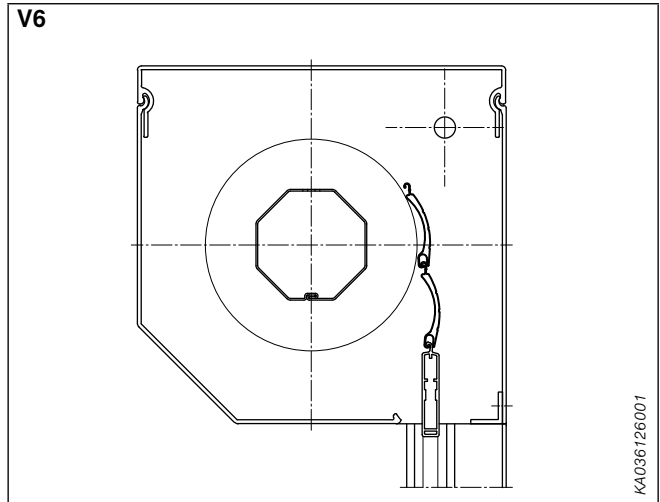
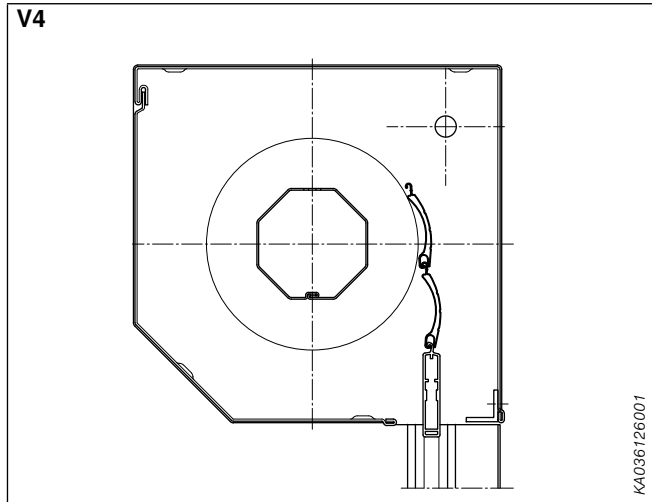

Fig. 67: V4/V6: Outlet gap closed

V4/V6: Angle bracket 15x15 mm, art. no. 114100, with riveted rear side

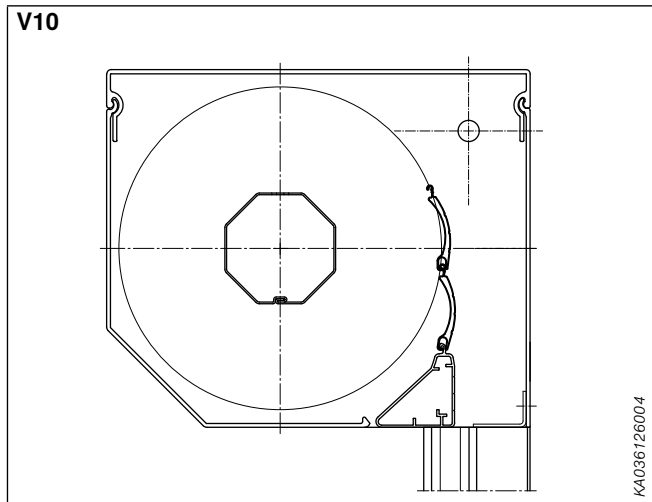

Fig. 68: V10: Outlet gap closed

V10: Angle bracket 25x17 mm, art. no. 502314, with riveted rear side

- The option "outlet gap closed" has to be ordered separately for models without insect screen.
- For subsequent retrofitting of an insect screen roller blind the angle bracket has to be removed.
- When retrofitting an insect screen swivel frame the angle bracket is required for the upper fastening of the frame profile.

Type matrix

V4	○	○	○	○
V6	○	○	○	○
V10	○	○	○	○

Legend:
 ● standard
 ○ optional
 - not possible

Box extensions

Front-mounted roller shutters

Type matrix

Box extension	available for		
	V4	V6	V10
Type 3	–	○	○
Type 4	–	○	○
Type 5	○	○	○
Type 6	○	○	○
Type 7	–	○	○
Type 8	–	○	○

Legend:

- standard
- optional
- not possible

Box extension type 3

Left rolling blind

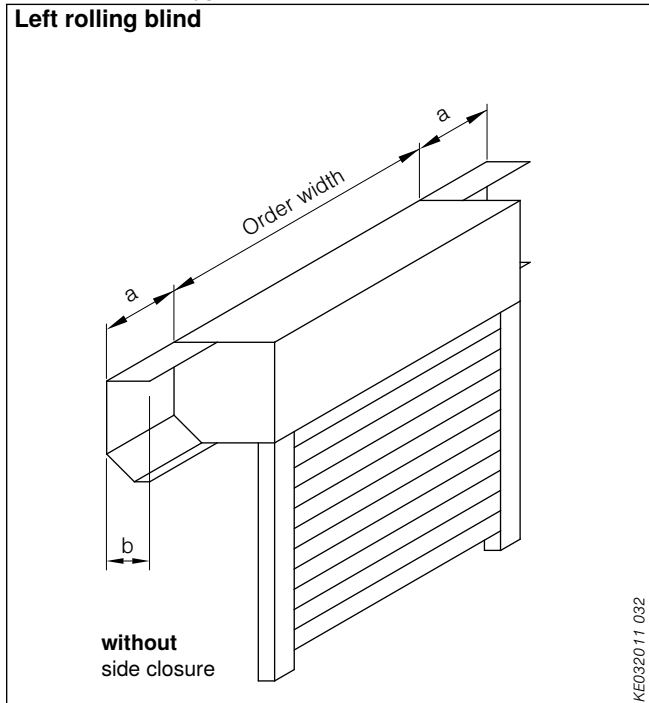

Fig. 69: Left rolling blind

Notes on box extension type 3:

- For extruded boxes with box shapes rectangular, round and square
- Without side closure
- Please state dimension of the extension "a" (one or both sides) as well as depth dimension "b"

Box extension type 4

Left rolling blind

Box extension 35 mm

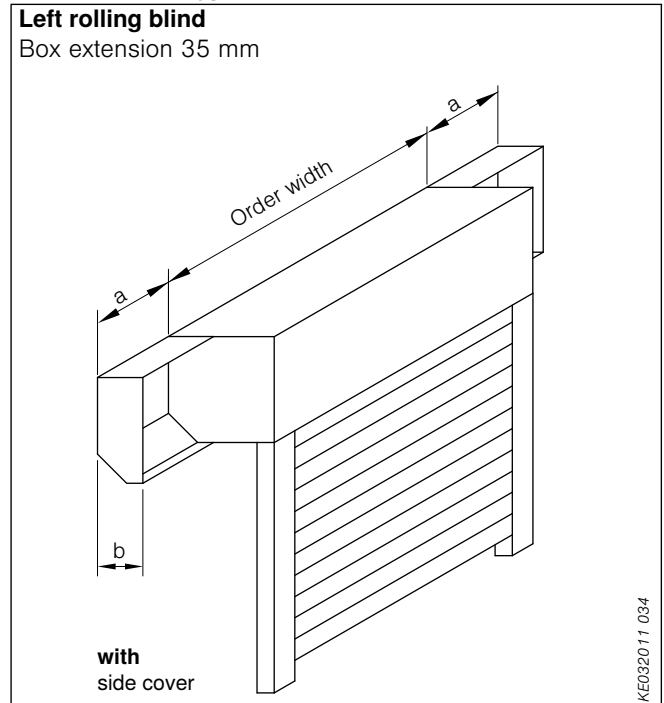

Fig. 70: Left rolling blind

Notes on box extension type 4:

- For extruded boxes with box shapes rectangular, round and square
- With side cover
- Please state dimension of the extension "a" (one or both sides), min. 35 mm, as well as depth dimension "b"

Box extensions

Front-mounted roller shutters

Box extension type 5

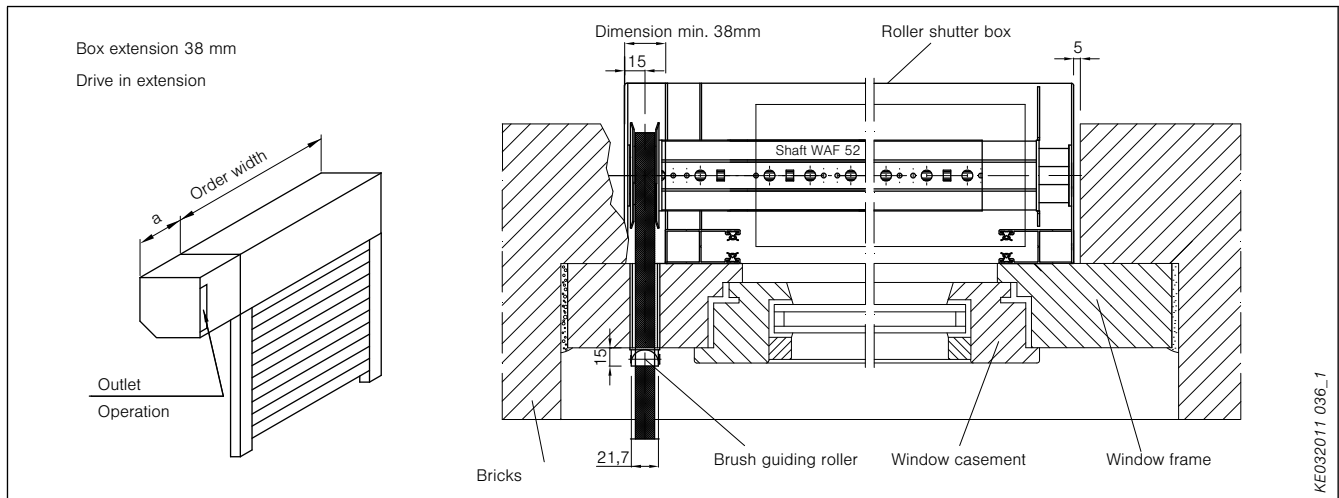

Fig. 71: Box extension type 5 (shown with belt operation)

Note on box extension type 5 (box visible):

- For box shapes rectangular, round and square, closed on 4 sides
- Please state dimension of the extension "a" (one or both sides)
- Outlet gap open as a standard, optionally closed
- If the outlet gap is closed, the box extension has to be min. 50 mm
- Belt (only width 14 mm), crank and motor drives in the extension
- The Minimax guide rail is not available for box extension type 5

Box extension type 5 (Plaster)

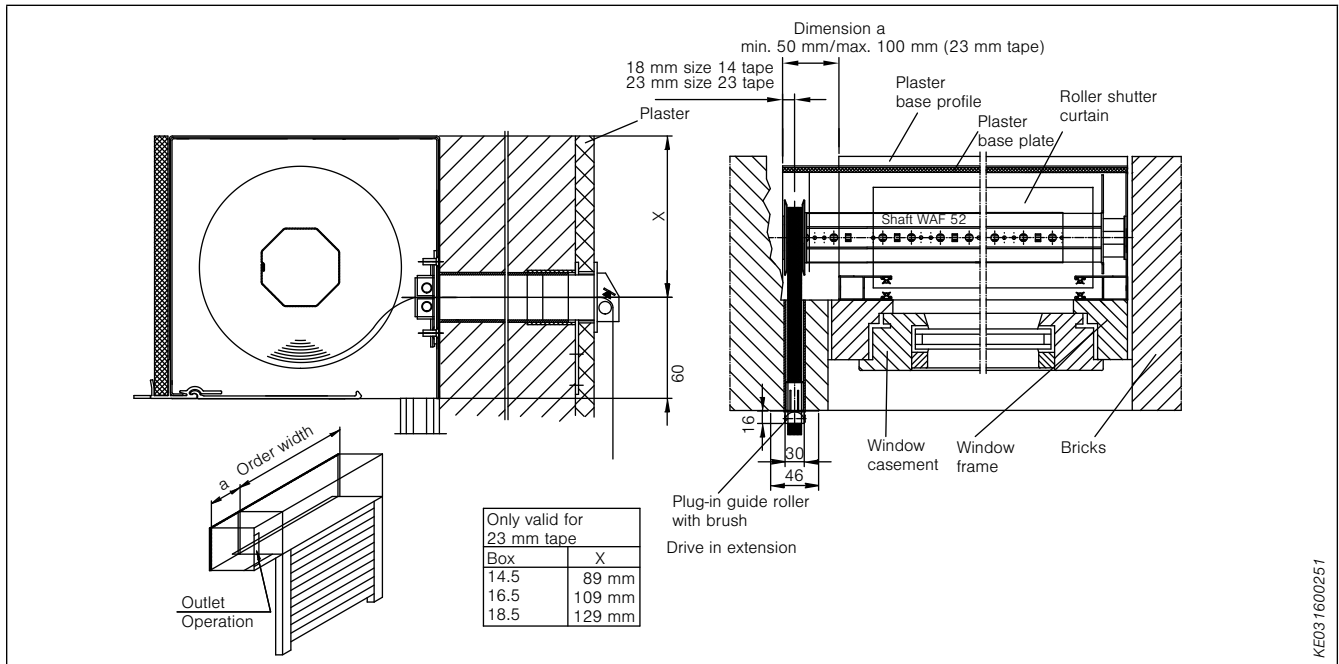

Fig. 72: Box extension type 5 (shown with belt operation)

Notes on box extension type 5 (box embedded in plaster):

- For box shape plaster, closed on 4 sides
- Please state dimension of the extension "a" (one or both sides)
- Belt, crank and motor drives in the extension
- Belt width 23 mm (standard): dimension a min. width 50 mm, max. 100 mm
- Belt width 14 mm (optional): dimension a min. width 38 mm
- Outlet gap open as a standard, optionally closed
- If the outlet gap is closed, the box extension has to be min. 50 mm
- Plaster base profile notched in the box extension
- The Minimax guide rail is not available for box extension type 5

Box extensions

Front-mounted roller shutters

Box extension type 6

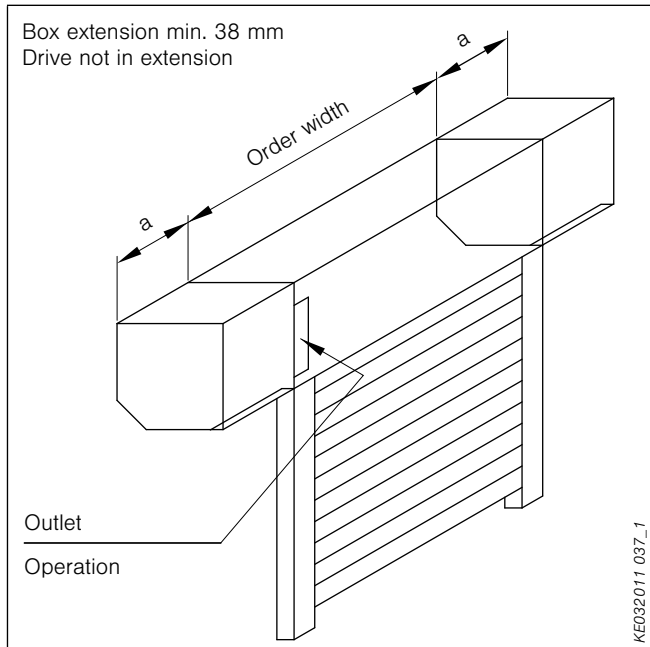

Fig. 73: Box extension type 6

Notes on box extension type 6

- For box shapes rectangular, round, square and plaster
- Please state dimension of the extension "a" (one or both sides)
- Belt and crank drives not in the extension
- Outlet gap open as a standard, optionally closed
- If the outlet gap is closed, the box extension has to be min. 50 mm
- If the outlet gap is closed, a box closed on 4 sides is required for the box types rectangular, round and square
- for box shape plaster the plaster base profile is cut out in the box extension

Box extension type 7 (blind box)

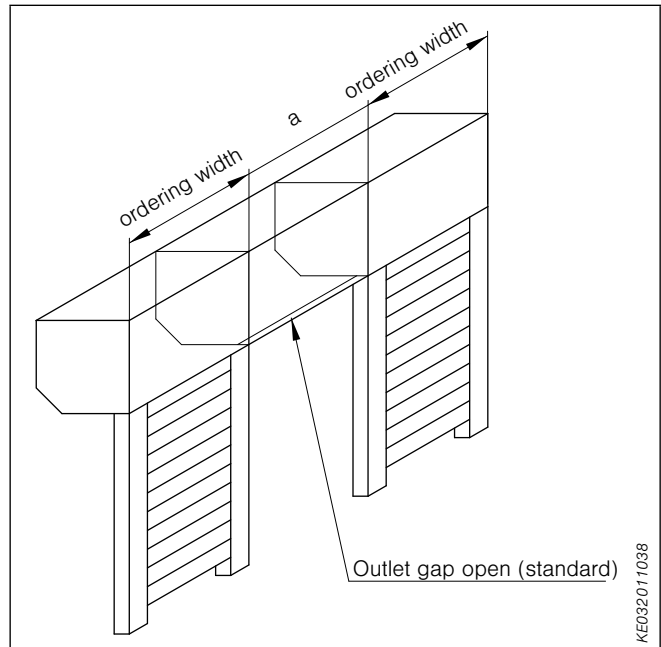

Fig. 74: Box extension type 7 for combination

Notes on box extension type 7

- For combinations with continuous box
- for extruded boxes
- For box shapes rectangular, round, square and plaster
- Please state dimension of the extension "a" as well as depth dimension "b"
- Outlet gap open as a standard, optionally closed
- If the outlet gap is closed, the box extension has to be min. 50 mm
- If the outlet gap is closed, a box closed on 4 sides is required for the box types rectangular, round and square

Box extensions

Front-mounted roller shutters

Notes on box extension type 8:

- For extruded boxes with box shapes rectangular, round, square and plaster.
- Only boxes closed on 4 sides
- Outlet gap open as a standard, optionally closed
- If the outlet gap is closed, the box extension has to be min. 50 mm

Box extension type 8 (mitred corner) – inner angle, single mitre

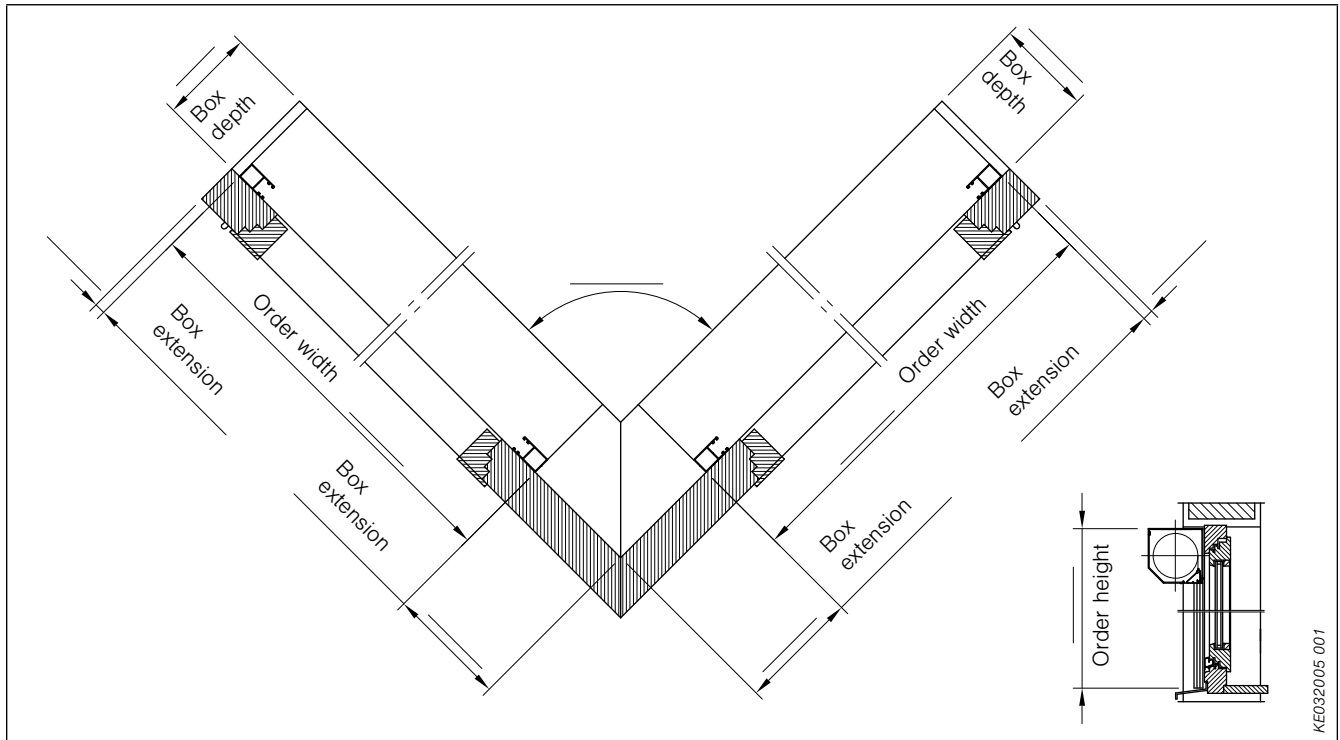

Fig. 75: Inner angle, single mitre

Box extension type 8 (mitred corner) – inner angle, polygonal

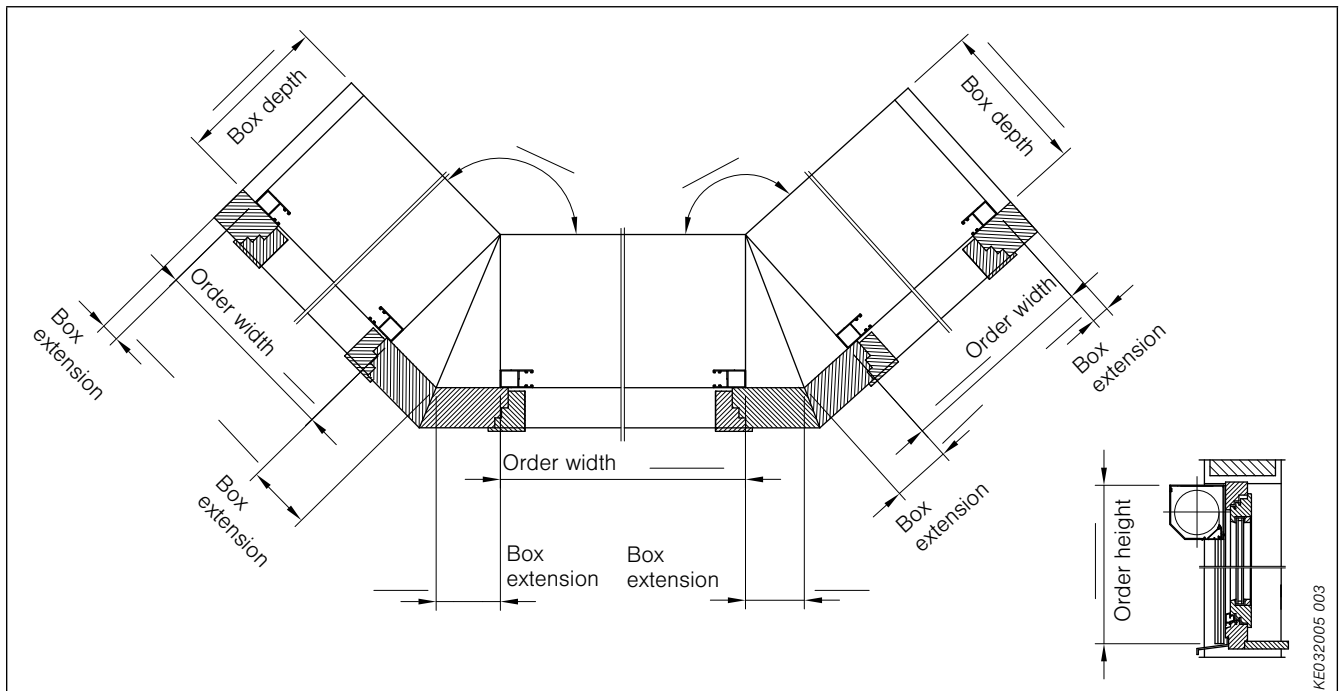

Fig. 76: Inner angle, polygonal

Box extensions
Front-mounted roller shutters

Box extension type 8 (mitred corner) – outer angle, single mitre

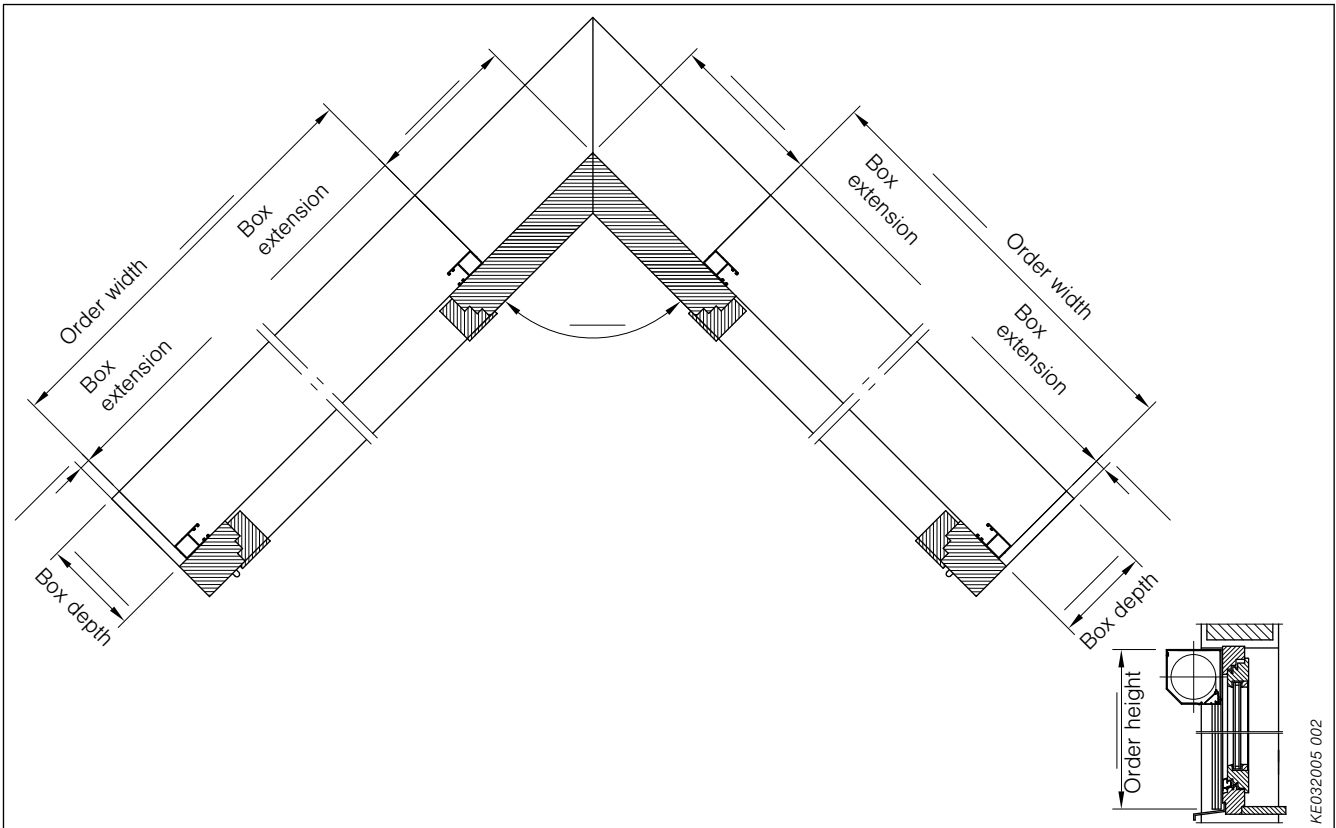

Fig. 77: Inner angle, single mitre

Box extension type 8 (mitred corner) – outer angle, polygonal

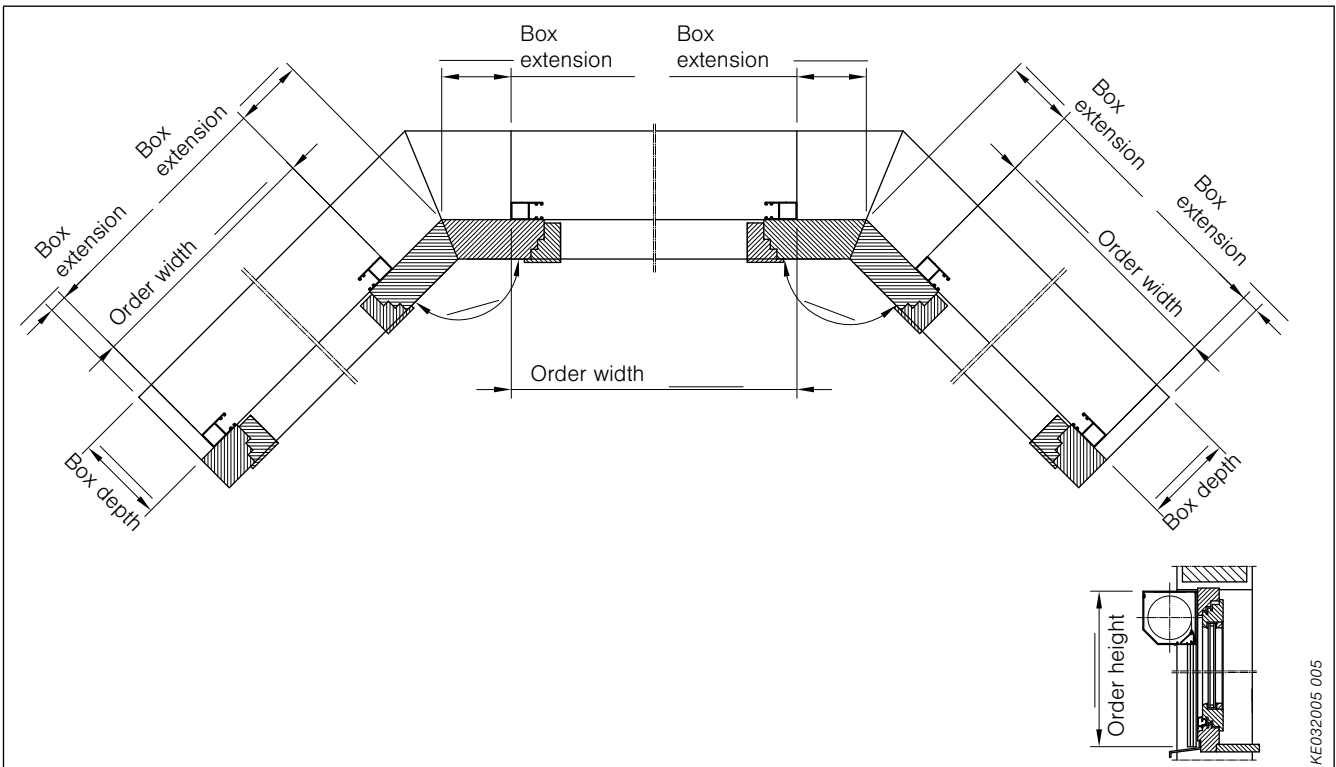

Fig. 78: Outer angle, polygonal

Box extensions

Front-mounted roller shutters

Notes on box extension type 8:

- For extruded boxes with box shapes rectangular, round, square and plaster.
- Only boxes closed on 4 sides
- Outlet gap open as a standard, optionally closed
- If the outlet gap is closed, the box extension has to be min. 50 mm

Outer angle 90°, cut-out in the box

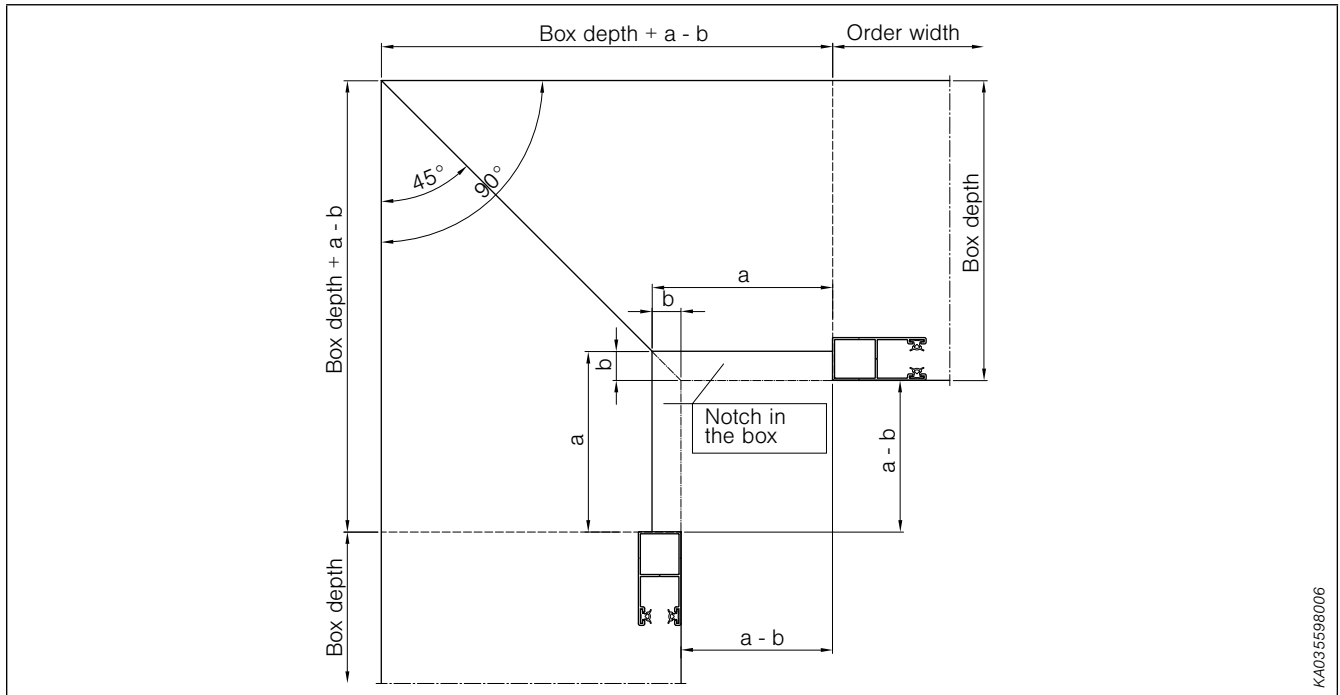

Fig. 79: Outer angle 90°, cut-out in the box

Combination of outside and inner angle

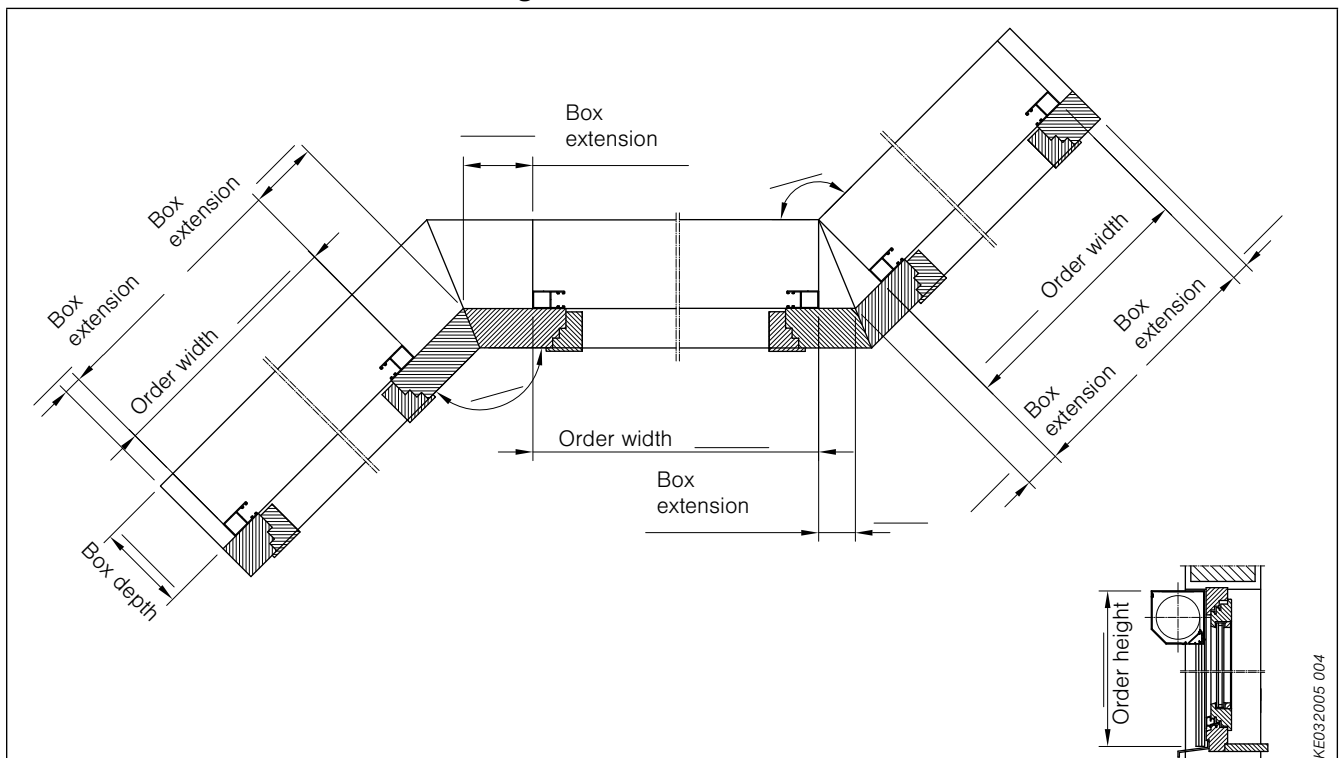

Fig. 80: Combination of outside and inner angle

Contents

Guide and end rails

Guide rails	108
Sealing strips for guide rails	117
End lockings for guide rails	118
End rails	119
Locking device for end rails	120

Guide rails

Front-mounted roller shutters

General information on guide rails:

- Always state the desired guide rail type in your order
- If not specified differently, we will use FSCH 55-25 for V4/V6
- Apart from the standard FSCH 55-25 guide rail, the guide rail FSCH 46-25 may also be used (taking into consideration the construction limit values for guide rails size 46!)
- Mixed orders with size 46 and 55 guide rails will be universally delivered with brush sealing strip (against a surcharge for size 55 guide rails)
- Half-round cover for guide rails with a visible width of 55 mm at a surcharge
- For centre rail size 85 only a half round cover centrally at window rail height is available.

Rear cover panel detail for distance guide rails

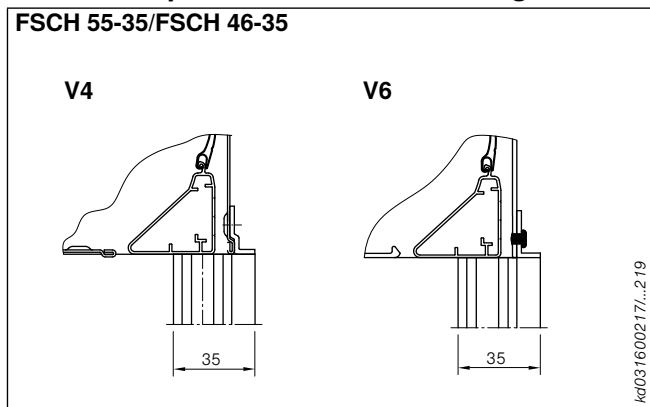
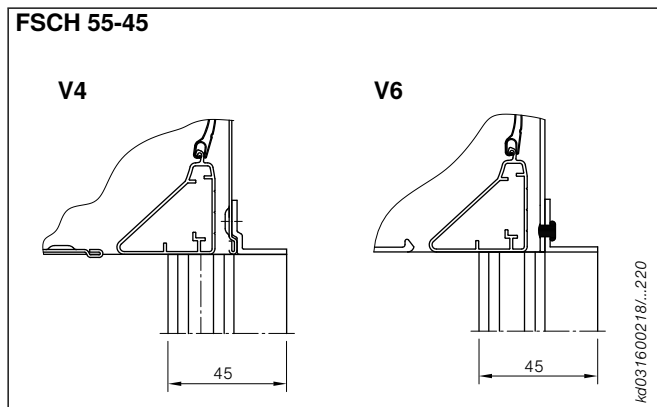

Fig. 81: Rear cover panel detail for distance guide rails

Note on rear cover panel detail:

- Must be stated separately when ordering.
- Only for boxes closed on all 4 sides.



Guide rails

Front-mounted roller shutters

Note:

All front-mounted roller shutters are only equipped with guide rails made of extruded aluminium.

Type	Drawing	Front drilled hole	Lateral drilled hole
Guide rails V4/V6 for left rolling blinds without insect screen			
FSCH 46-25 not for A 44, A 53 and S 37			
FSCH 55-25			
FSCH 67-25 not for A 44, A 53 and S 37			
FSCH 85-25			
FSCH 80-25			

Guide rails

Front-mounted roller shutters

Note:

All front-mounted roller shutters are only equipped with guide rails made of extruded aluminium.

Type	Drawing	Front drilled hole	Lateral drilled hole
Guide rails V4/V6 for left rolling blinds, optionally with insect screen (suitable for retrofitting)			
FSCH 55-47 not for A 44, A 53 and S 37			
FSCH 84-47 not for A 44, A 53 and S 37			
FSCH 29-25			
Guide rails V4/V6 for left rolling blinds with integrated insect screen roller blind			
FSCH 55-46 not for A 44, A 53 and S 37			
FSCH 84-46 not for A 44, A 53 and S 37			

Guide rails

Front-mounted roller shutters

Note:

All front-mounted roller shutters are only equipped with guide rails made of extruded aluminium.

Type	Drawing	Front drilled hole	Lateral drilled hole
Distance guide rails V4/V6 for left rolling blinds without insect screen¹⁾			
FSCH 46-35¹⁾ not for A 44, A 53 and S 37			
FSCH 55-35¹⁾			
FSCH 85-35¹⁾			
FSCH 55-45¹⁾			
FSCH 55-65¹⁾			

¹⁾ in connection with rear cover panel detail

Guide rails

Front-mounted roller shutters

Note:

All front-mounted roller shutters are only equipped with guide rails made of extruded aluminium.

Type	Drawing	Front drilled hole	Lateral drilled hole
FSCH 55-75 ¹⁾			

¹⁾ in connection with rear cover panel detail

Guide rails

Front-mounted roller shutters

Note:

All front-mounted roller shutters are only equipped with guide rails made of extruded aluminium.

Type	Drawing	Front drilled hole	Lateral drilled hole
Guide rails V6 Q for right rolling blinds without insect screen			
FSCH 46-85 not for A 44, A 53 and S 37			
FSCH 55-85			

Guide rails

Front-mounted roller shutters

Note:

All front-mounted roller shutters are only equipped with guide rails made of extruded aluminium.

Type	Drawing	Front drilled hole	Lateral drilled hole
Guide rails V10 with integrated insect screen			
FSCH 55-48			
FSCH 84-48			
Guide rails V10 optionally with insect screen roller blind (suitable for retrofitting) or with solar drive			
FSCH 55-52			
FSCH 85-52			
FSCH 29-25			
Half-round cover for V4, V6, V10 (optional)			
for guide rails with a visible width of 55 mm			

Guide rails

Front-mounted roller shutters with Minimax guide rails

Note:

All front-mounted roller shutters are only equipped with guide rails made of extruded aluminium.

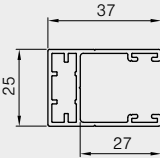
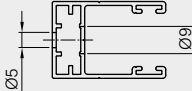
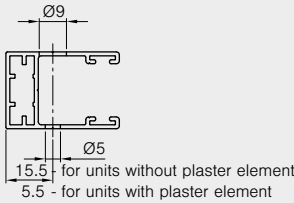
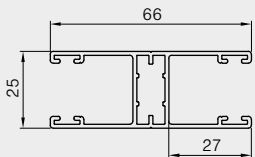
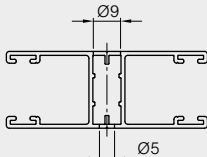
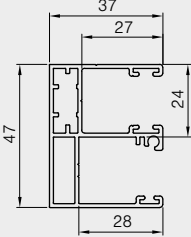
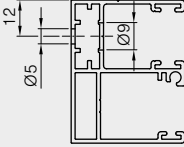
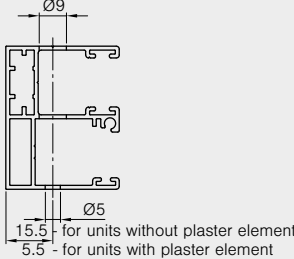
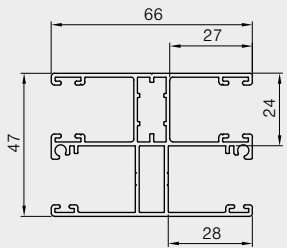
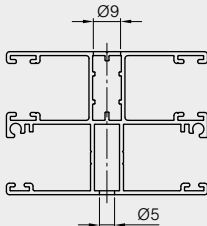
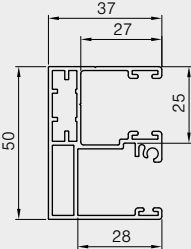
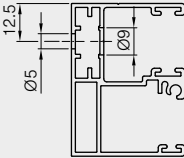
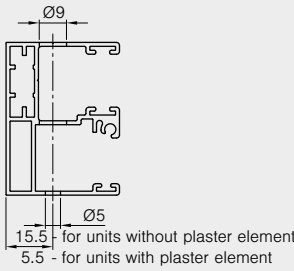
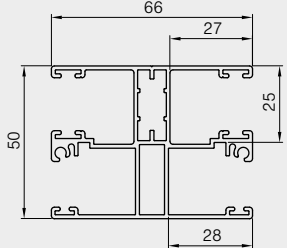
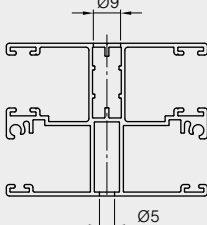
Type	Drawing	Front drilled hole	Lateral drilled hole
Minimax guide rails V4/V6			
FSCH 37-25			
FSCH 66-25			
FSCH 37-46			
FSCH 66-46			
Minimax guide rails V10			
FSCH 37-48			
FSCH 66-48			

Guide rails





Front-mounted roller shutters with reinforced guide rails

Note: All front-mounted roller shutters are only equipped with guide rails made of extruded aluminium.

Type	Drawing	Front drilled hole	Lateral drilled hole
Reinforced guide rails for V6 without insect screen (security package)			
FSCH 60-25			
FSCH 95-25			
Reinforced guide rails for V6 with integrated insect screen (security package)			
FSCH 60-47 not for A 44, A 53 and S 37			
FSCH 95-47 not for A 44, A 53 and S 37			
Reinforced guide rails for V10 with integrated insect screen roller blind (security package)			
FSCH 60-48			
FSCH 94-48			

Sealing strips for guide rails

Front-mounted roller shutters

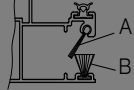
Minimum aperture in mm	Sealing strip categories							
								
Designation of strip	Co-Ex strip	Brush sealing strip, short	Brush sealing strip, long				PE strip	Brush sealing strip for insect screen roller blind
Art. No. sealing strip	301203	301045	301065				301093	A = 301224 B = 301313
Used for profile	A 36, A 44, K 36, V 36	A 53	A 36	A 44	K 36	V 36	S 37	Insect screen roller blind
for type V4/V6								
FSCH 46-25	-	-	●	-	●	●	-	-
FSCH 55-25	●	●	○	○	○	○	●	-
FSCH 67-25	-	-	●	-	●	●	-	-
FSCH 85-25	●	●	○	○	○	○	-	-
FSCH 80-25	●	●	○	○	○	○	●	-
FSCH 55-47	-	-	● ¹⁾	-	● ¹⁾	● ¹⁾	-	-
FSCH 84-47	-	-	● ¹⁾	-	● ¹⁾	● ¹⁾	-	-
FSCH 29-25	-	-	-	-	-	-	-	●
FSCH 55-46	-	-	● ¹⁾	-	● ¹⁾	● ¹⁾	-	●
FSCH 84-46	-	-	● ¹⁾	-	● ¹⁾	● ¹⁾	-	●
FSCH 46-35	-	-	●	-	●	●	-	-
FSCH 55-35	●	●	○	○	○	○	●	-
FSCH 85-35	●	●	○	○	○	○	-	-
FSCH 55-45	●	●	○	○	○	○	●	-
FSCH 55-65	●	●	○	○	○	○	●	-
FSCH 55-75	●	●	○	○	○	○	●	-
FSCH 46-85	-	-	●	-	●	●	-	-
FSCH 55-85	●	●	○	○	○	○	●	-
for type V10								
FSCH 55-48	●	-	○	○	○	○	●	●
FSCH 84-48	●	-	○	○	○	○	-	●
FSCH 55-52	●	-	○	○	○	○	●	-
FSCH 85-52	●	-	○	○	○	○	-	-
for front-mounted roller shutters with Minimax guide rails								
FSCH 37-25	●	-	○	○	○	○	-	-
FSCH 37-46	-	-	● ¹⁾	-	● ¹⁾	● ¹⁾	-	●
FSCH 37-48	●	-	○	○	○	○	-	●
FSCH 66-25	●	-	○	○	○	○	-	-
FSCH 66-46	-	-	● ¹⁾	-	● ¹⁾	● ¹⁾	-	●
FSCH 66-48	●	-	○	○	○	○	-	●
for models with security package:								
FSCH 60-25	●	●	○	○	-	-	-	-
FSCH 95-25	●	●	○	○	-	-	-	-
FSCH 60-47	-	-	● ¹⁾	-	-	-	-	-
FSCH 95-47	-	-	● ¹⁾	-	-	-	-	-
FSCH 60-48	●	-	○	○	-	-	-	●
FSCH 94-48	●	-	○	○	-	-	-	●

¹⁾ Combination of short (art. no. 301045) and long (art. no. 301065) sealing strip

Legend:



- standard
- optionally available
- not possible



End lockings for guide rails

Front-mounted roller shutters

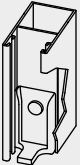
Standard end lockings

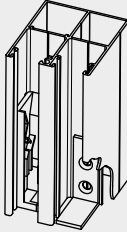
End locking illustration	Art. no.	Standard end lockings for roller shutter guide rail		Art. no. end locking for insect screen guide rail
		type V4/V6	type V10	
	314136	46-25, 67-25 46-35, 46-85	-	-
	314135	55-25, 85-25 80-25, 55-35 85-35, 55-45 55-65, 55-75 55-85, 60-25 95-25	55-48, 84-48 55-52, 85-52, 60-48, 94-48	313494
	520116	55-47, 84-47 55-46, 84-46 37-25, 66-25 37-46, 66-46 60-47, 95-47	37-48, 66-48	313494

Special end lockings¹⁾

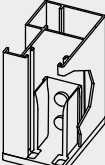
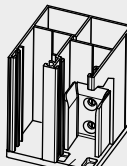
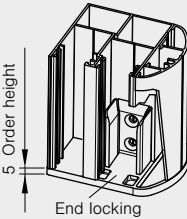
End locking illustration	Art. no.	Standard end lockings for roller shutter guide rail		Art. no. end locking for insect screen guide rail
		type V4/V6	type V10	
	left 314026 right 314027	55-35	-	313494
	left 314098 right 314099	-	55-48, 55-52	313494
	left 314093 right 314094	-	55-48 and 55-52 with half-round cover	313494

¹⁾ Attention! Take 5 mm protrusion into consideration when taking measurements.

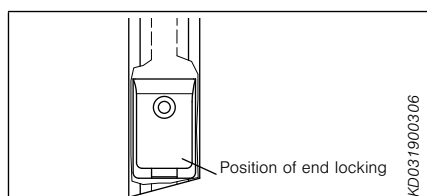

Notes on end lockings:

- End lockings are not included in the standard scope of delivery and have to be stated separately when ordering
- If no specific request is made for end lockings we will assume that an internal end locking is required

End rails

Front-mounted roller shutters

Notes:

- Available for all drives, incl. motor with torque overload protection.
- Standard end rail without sealing strip

Triangular design end rails

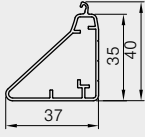
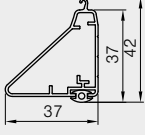
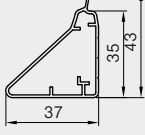
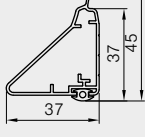
End rail type	possible roller shutter curtain					
	A36	A44	A53	S37	K36	V36
 without sealing strip	●	●	-	●	●	●
 with sealing strip	○	○	-	○	○	○
 without sealing strip	-	-	●	-	-	-
 with sealing strip	-	-	○	-	-	-

Flat end rails

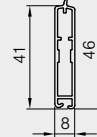
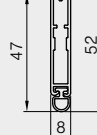
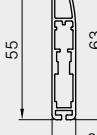
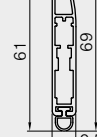
End rail type	possible roller shutter curtain					
	A36	A44	A53	S37	K36	V36
 without sealing strip	●	●	-	●	●	●
 with sealing strip	○	○	-	○	○	○
 without sealing strip	-	-	●	-	-	-
 with sealing strip	-	-	○	-	-	-

Legend:

● standard ○ optional - not available

Handle rail for insect screen gauze
 when using an insect screen roller blind (optional for V4/V6, standard for V10)

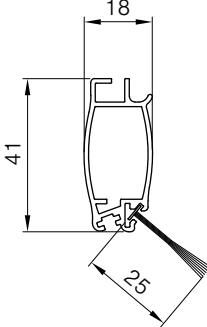

KD031900279v1

Fig. 82: Handle rail for insect screen gauze

Locking device for end rails

Front-mounted roller shutters

Notes:

- Available for all drives, incl. motor with torque overload protection.
- Locking device only available in combination with flat end rail.

Sliding bolt

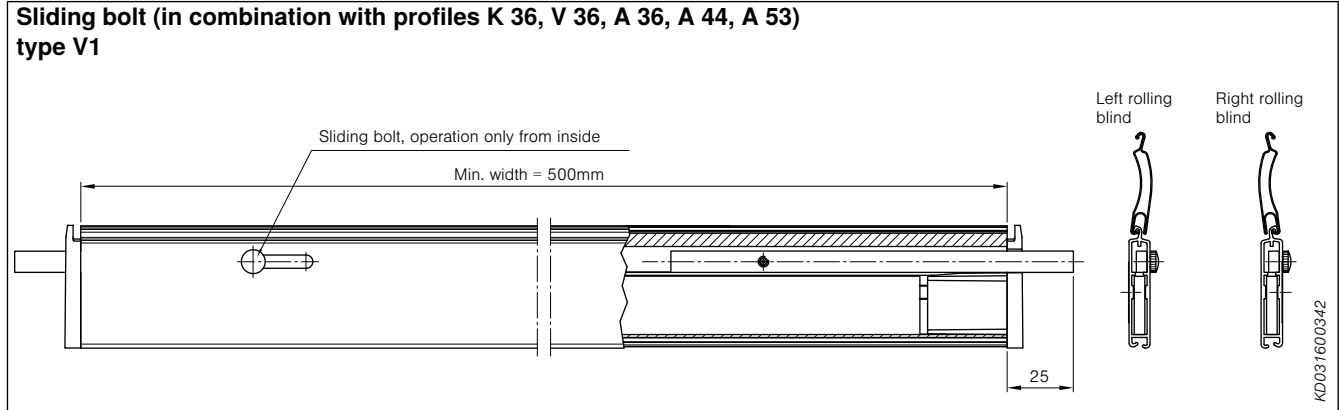

Fig. 83: Sliding bolt type V7

Type matrix

V4	-	-	-	-
V6	o	o	o	o
V10	o	o	o	o

Espagnolette lock

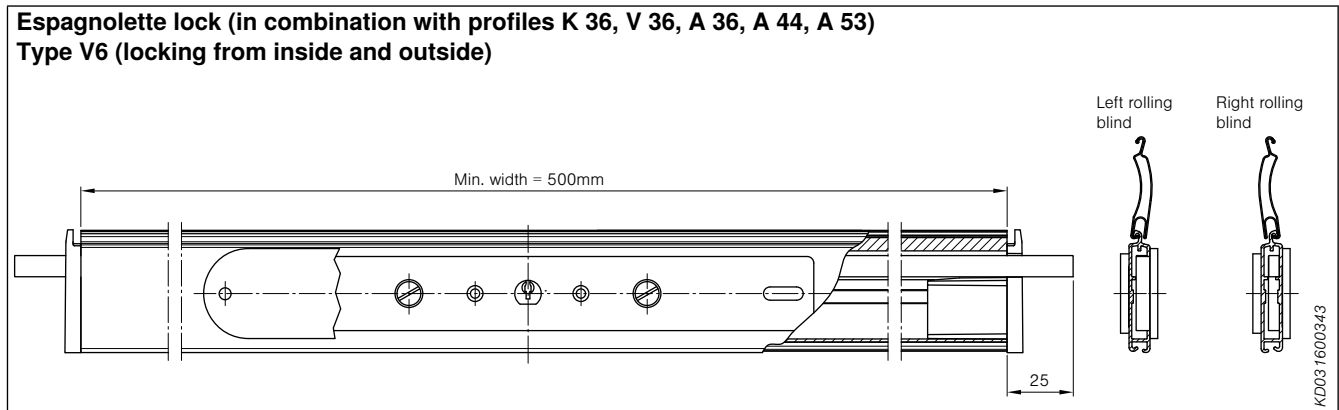

Fig. 84: Espagnolette lock

Note on espagnolette locks:

Clearance between window frame and guide rails min. 50 mm.

Type matrix

V4	-	-	-	-
V6	o	o	o	o
V10	o	o	o	o

Contents

Security roller shutters

Description	122
Construction limit values	124
Determining dimensions/order data	125
Operation details	126
Box dimensions/details	127
Guide rails and fixing materials	128
Guide rails/end rail	129
Certificate	130
Test certificate	131

Description

Security roller shutter FR 23/FR 24

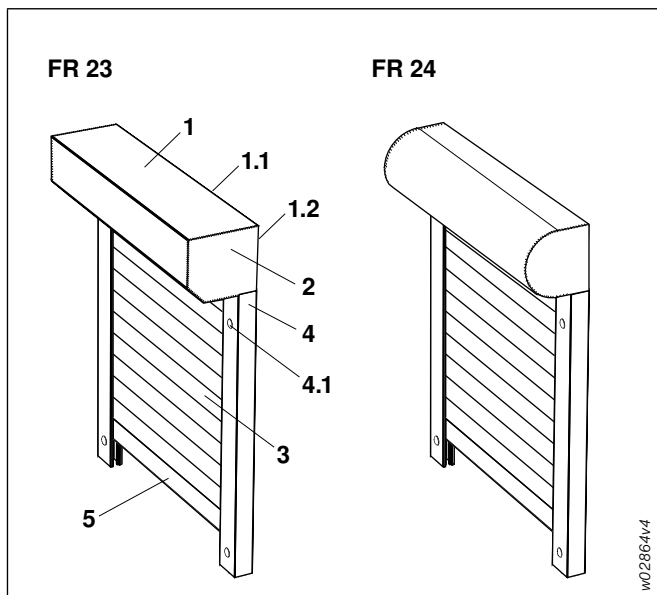

Fig. 85: Security roller shutter FR 23/FR 24

- 1 Box**
 - 1.1 Inspection cover
 - 1.2 Side cover
- 2 Shaft**
- 3 Roller shutter curtain**
- 4 Lateral guidance**
 - 4.1 Locking pin
- 5 End rail**

Application

This roller shutter has a resistance class 2 classification and offers particularly effective burglary protection (WK 2 is equivalent to the new RC 2 classification). The roller shutter is equipped with reinforced components and is suitable for retrofitting as well as for new buildings.

Burglary resistant properties certified in accordance with WK2 for dimensions of up to 2250x2500 mm (WxH).

Operation

Motor

with torque overload protection; no operating switch

Voltage: 230 V AC

Frequency: 50 Hz

Protection class: IP 44

Cable whip (L): 1000 mm, optionally 2500 mm or 5000 mm

Radio receiver (optional)

EWFS plug receiver with EWFS hand-held transmitter, 1 channel

Crank

Crank rod with collapsible crank; sealed joint plate and square with thermal separation

Material: aluminium

Surface: C0 anodised, optionally powder-coated in RAL 9016 or anodised C34

Crank holder: plastic, grey, white or brown, crank holder with magnet optional

Box (1)

2 box sizes, closed on 4 sides

Box shapes: rectangular, round

Material: aluminium, folded

Material thickness: 2 mm

Dimensions: see box cross-sections

Surface: powder-coated

Box available as left rolling blind

Maximum box width 3000 mm.

Inspection cover (1.1)

Material: aluminium, folded

Surface: powder-coated

Inspection access at the back.

Side cover (1.2)

Material: aluminium

Surface: powder-coated

Side covers welded to cover panel.

FR 23 – box size 16

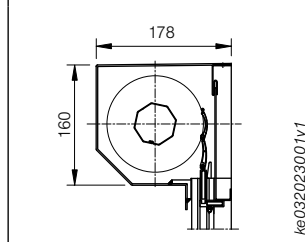

FR 23 – box size 18

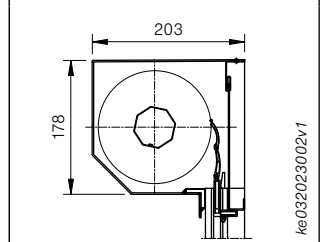

FR 24 – box size 16

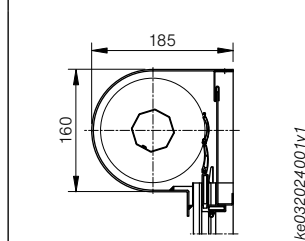

FR 24 – box size 18

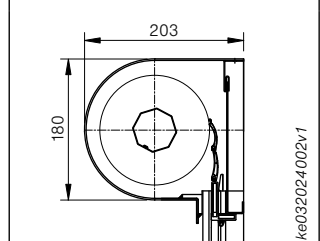

Fig. 86: Box

Ordering heights per box size in mm

Box size	Roller shutter profile S 37
16	1500
18	2500

Shaft (2)

Material: steel, zinc-coated

Material thickness: 0.8 mm

Dimensions (WAF): 52 mm

Profile: octagonal

Surface: plain

Description

Security roller shutter FR 23/FR 24

Roller shutter curtain (3)

without light slots

S 37

Material: aluminium, double walled, extruded
Fastening: directly on the shaft
Surface: powder-coated
Push-up guard with automatic locking device.
Hooked into the guide rails.

Lateral guide (4 and 4.1)

Security guide rails (4)

with reinforced front leg

Material: aluminium, extruded
Dimensions (w x d): 75 x 52 mm
Fixing: stepped drilled hole in the guide rail
Surface: powder-coated
Sealing strip: plastic
Guide rails with dismantling protection using locking pins (4.1).

End rail (5)

reinforced (for increased security), with stop squares, incl. plastic sealing strip

Material: aluminium, extruded
Surface: powder-coated

Colours

Powder coating of aluminium parts (except roller shutter curtains) with chrome-free pre-treatment in accordance with valid RAL CLASSIC colour chart (except camouflage and luminous colours) or in DB colours 701, 702 and 703, as well as eight textured colours (W4914 - W4921), four anodised-look colours (WC31 - WC34), and further colours according to WAREMA standard colour chart (in WAREMA colour specification).
Other colour specifications or special colours are available upon request and at a surcharge.
Roller shutter curtain according to WAREMA colour chart for roller shutter profiles, powder-coating optional in accordance with RAL Classic colour chart.

You can also use our free planning program at www.sonnenschutzplaner.de for planning the sun shading systems – configure the product and generate a technical drawing that can be integrated into your plans.

Construction limit values

Roller shutter curtain	Limit values			Operation modes and max. areas in m ²	
	Max. width in mm	Max. height in mm	Max. area individ. units in m ²	Crank, internal	Motor with torque overload protection
S 37	3000	2500	5.6	1.6	5.6
Min. order width in mm				520	800

Notes:

- Only individual boxes, no coupling possible!
- Please observe the maximum measurements for individual areas!
- All dimensions achieve wind resistance class 6.

Construction limit values

Security roller shutter FR 23/FR 24

Maximum dimensions for individual areas in mm

Height	Width																								
	900	1000	1100	1200	1300	1400	1500	1600	1700	1800	1900	2000	2100	2200	2300	2400	2500	2600	2700	2800	2900	3000			
1000															Resist. class 2 tested										S 37
1100																									
1200																									
1300																									
1400																									
1500																									
1600																									
1700																									
1800																									
1900																									
2000																									
2100																									
2200																									
2300																									
2400																									
2500																									

The wind resistance classes for each roller shutter profile can be found in the chapter "General information".

Determining dimensions/order data

Security roller shutter FR 23/FR 24

General information:

- Note deductions measurements (see details)
- Order width = back edge of guide rails
- Ordering height = bottom edge of guide rails to top edge of box
- Operation side, seen from inside
- State box size if not standard (see construction limit values)

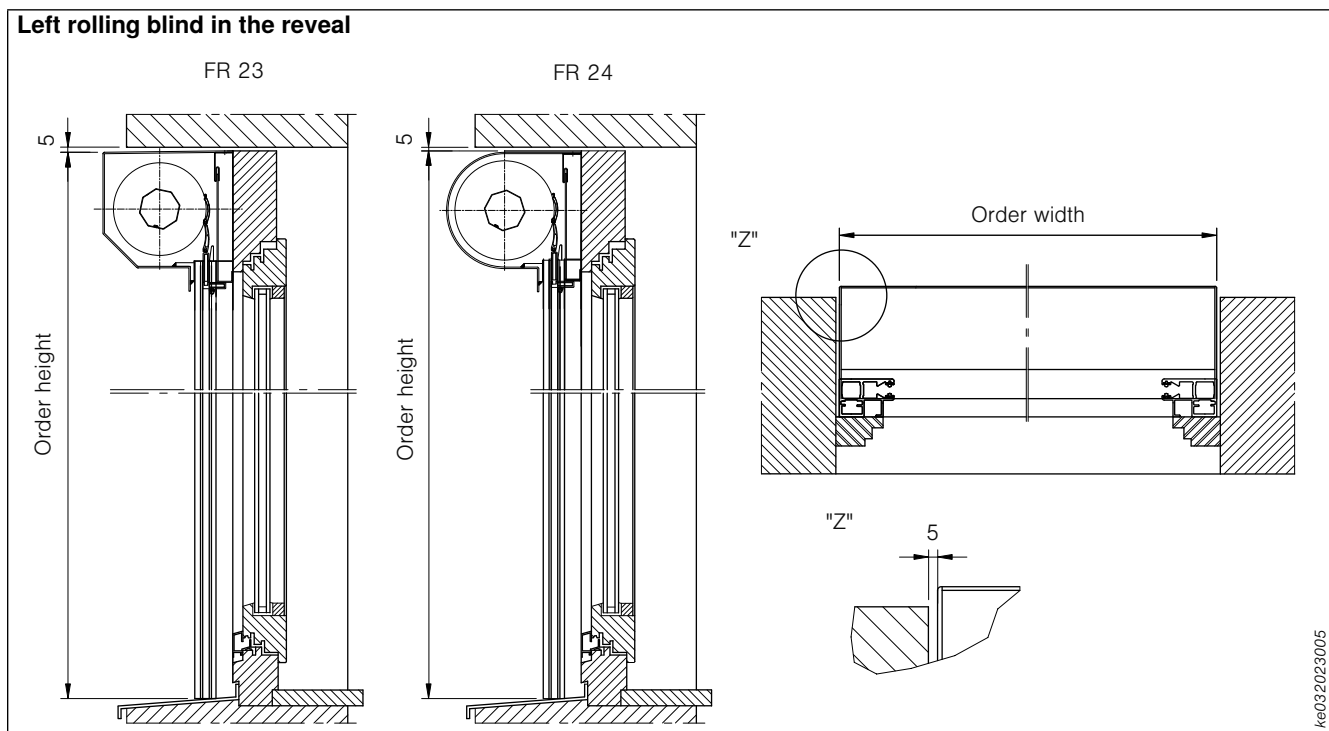

Fig. 87: Left rolling blind in the reveal

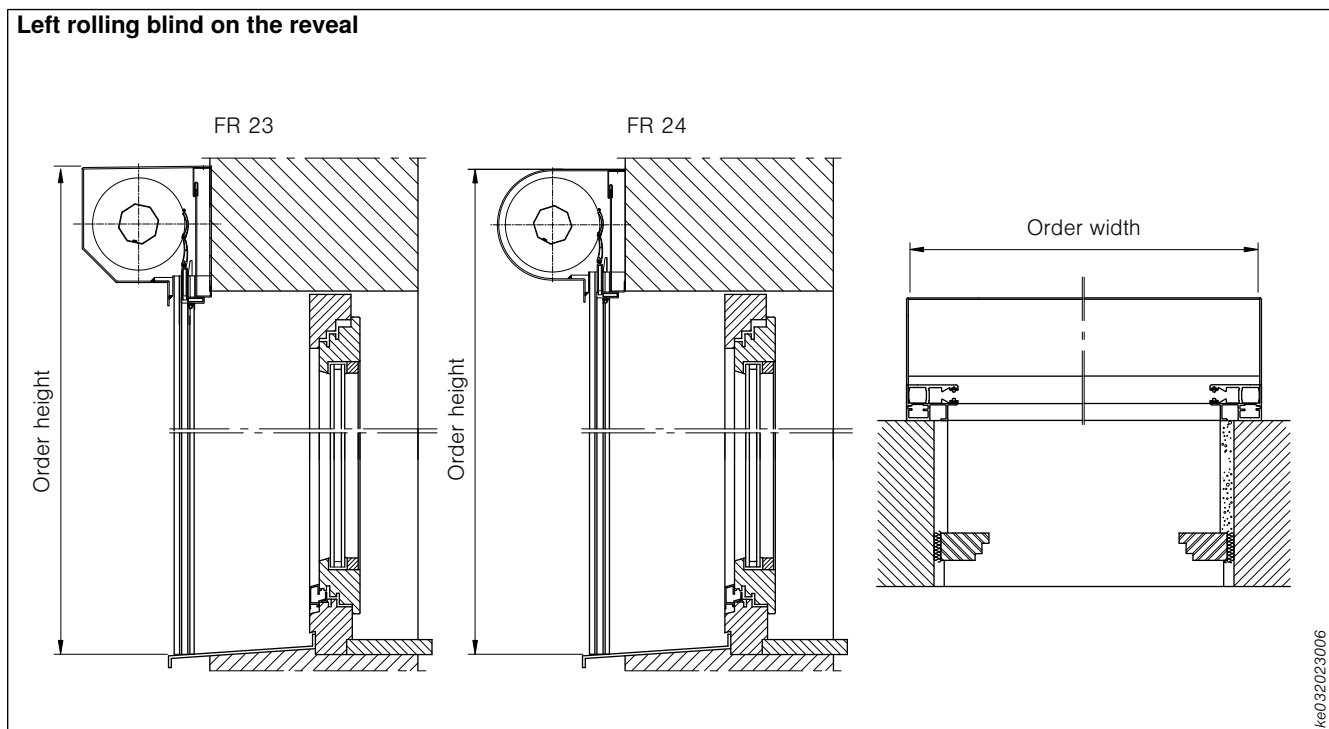

Fig. 88: Left rolling blind on the reveal

Operation details

Security roller shutter FR 23/FR 24

Crank

Internal crank drive type 1
 Standard: horizontal outlet
 Gear outlet: Square WAF 6 mm,
 continuously pivotable: max. 30°,
 with thermal separation

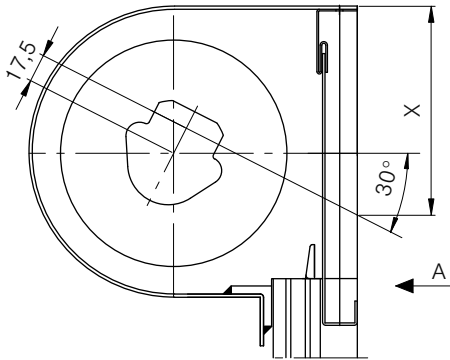
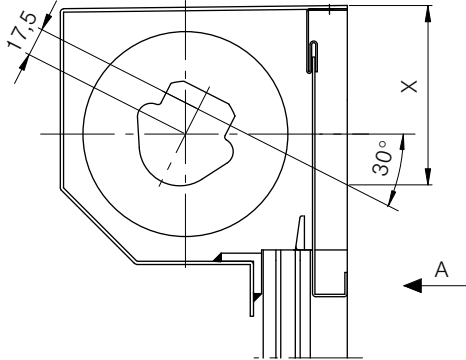

View "A"

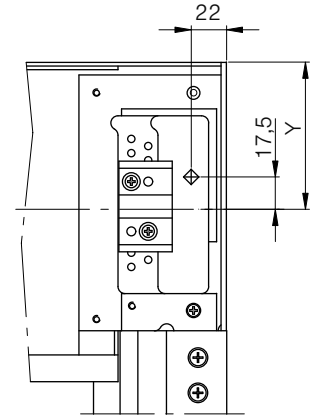

Box size	X	Y
16	118	80
18	136	88

Box size	X	Y
16	118	80
18	136	90

ke032023004

Fig. 89: Crank

Motor

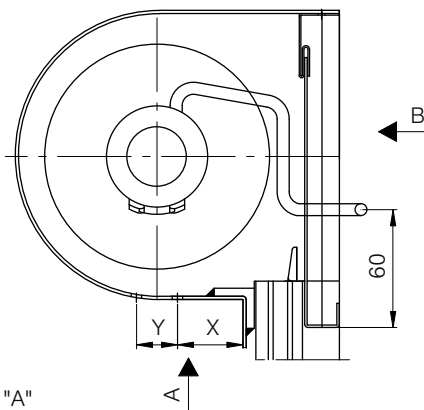
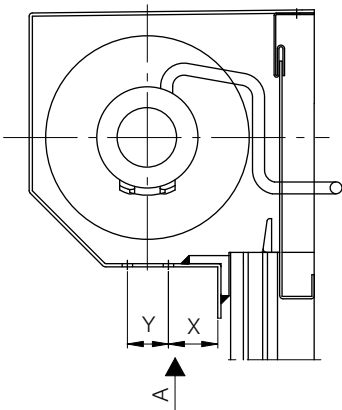

View "B"

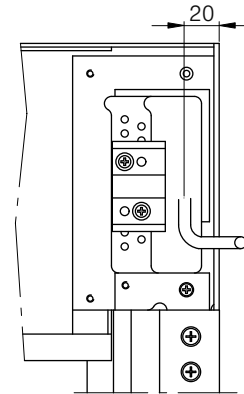

Box size	X	Y
16	35	25
18	39	30

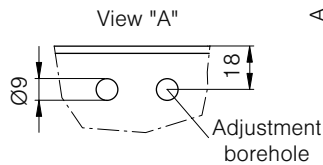

Note: There are two adjustment boreholes on the cover panel to allow for subsequent correction of the motor adjustment without dismantling the roller shutter. The adjustment boreholes are sealed with cover plugs.

ke032023008

Fig. 90: Motor

Box dimensions/details

Security roller shutter FR 23/FR 24

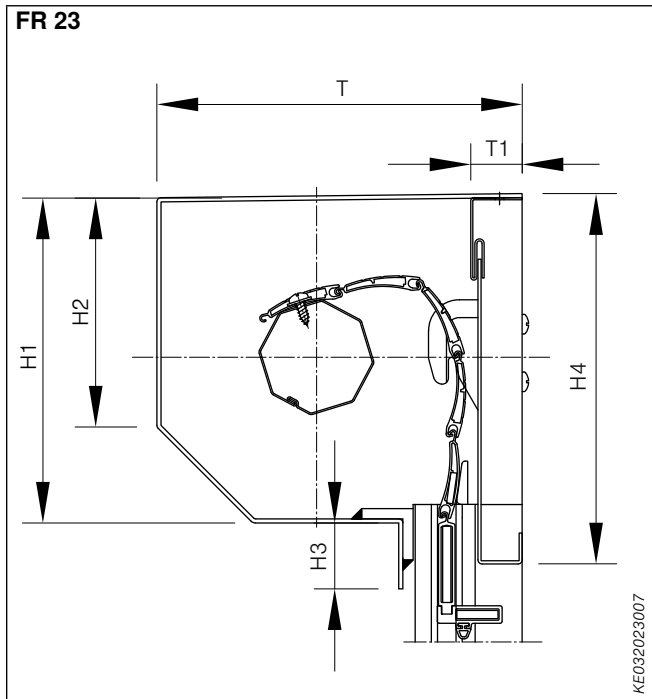

Fig. 91: FR 23

Box size	Dimensions					
	H1	H2	H3	H4	T	T1
16	160	111	32	180	178	25
18	178	126	32	200	203	25

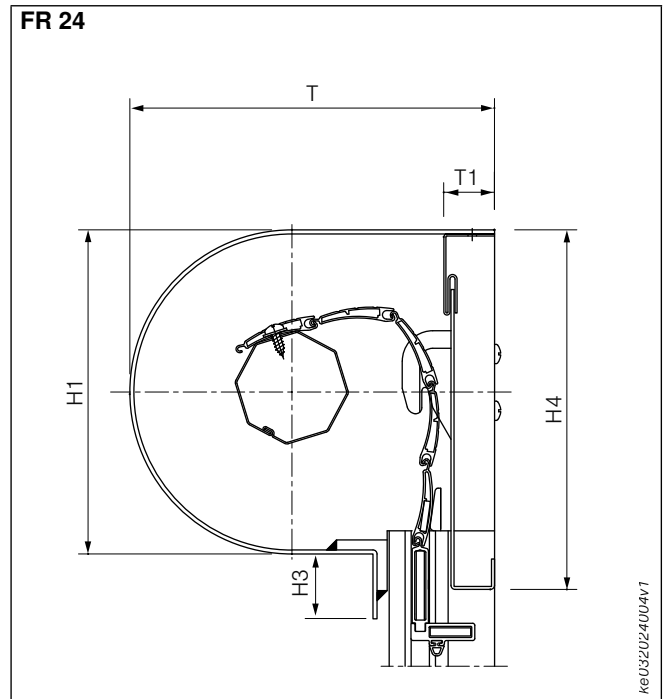

Fig. 93: FR 24

Box size	Dimensions				
	H1	H3	H4	T	T1
16	160	32	178	185	25
18	180	32	198	203	25

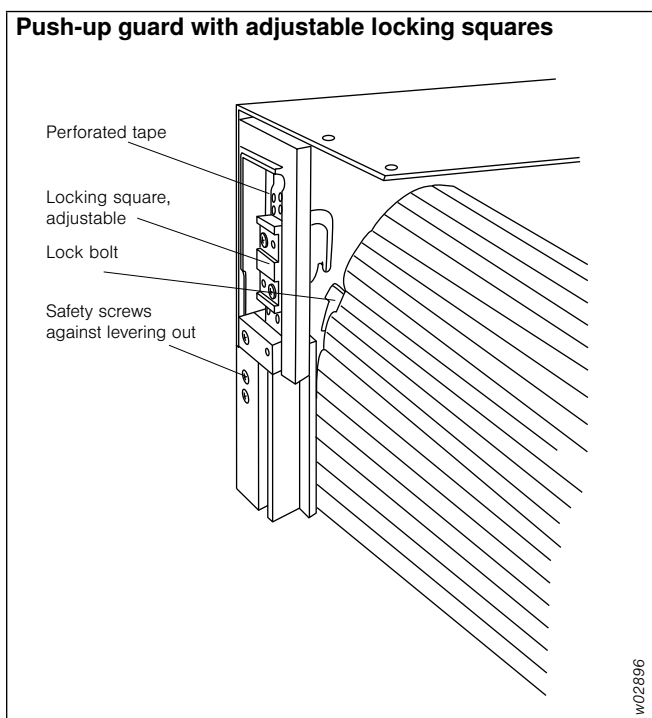

Fig. 92: Push-up guard with adjustable locking squares

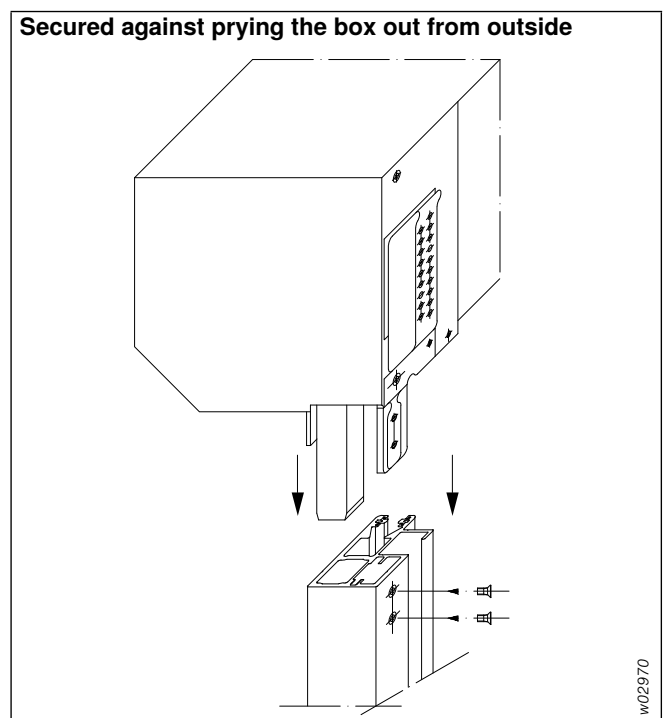

Fig. 94: Secured against prying the box out from outside

Guide rails and fixing materials

Security roller shutter FR 23/FR 24

Guide rails

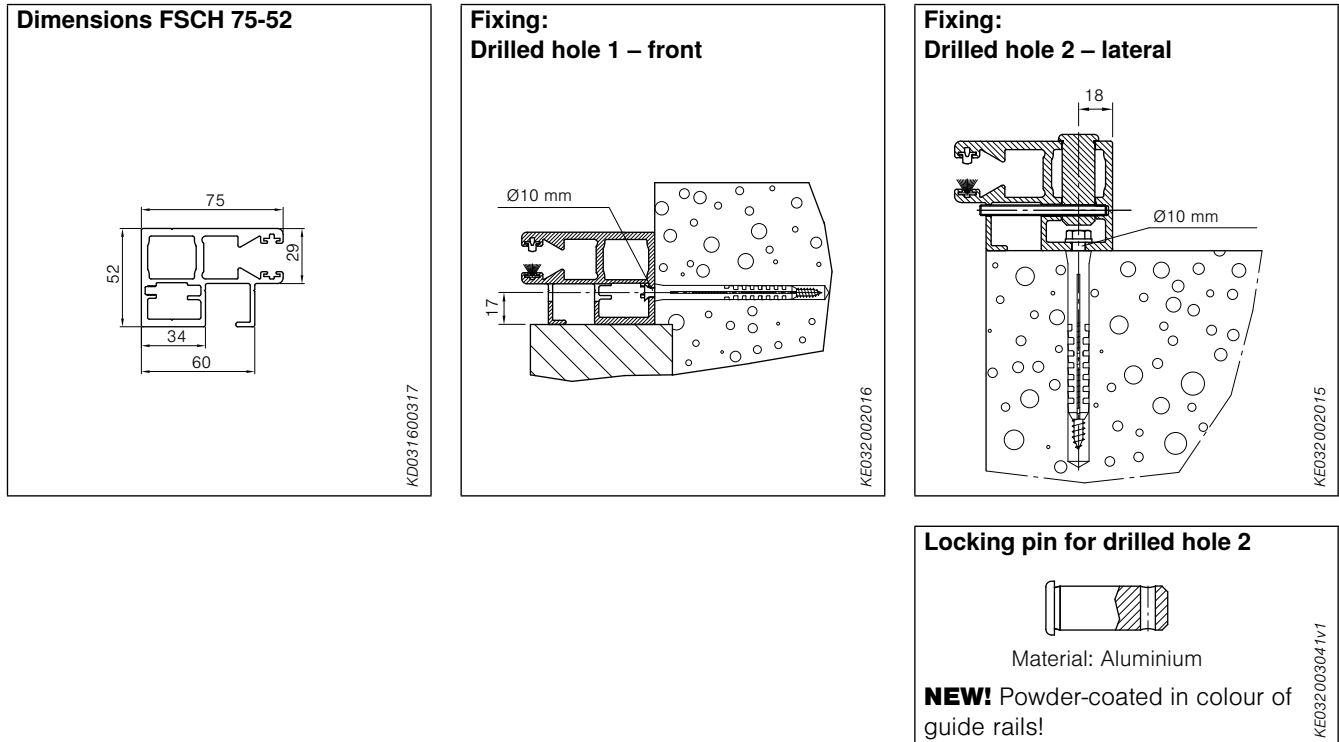

Fig. 95: Fixing

General information about fixing material:

We recommend using the fixing material described here. Other fixing materials cannot be supplied (appropriate fixing must be ensured by the customer).

Mounting security roller shutters on aluminium or plastic windows is **not** covered by the test certificate complying with resistance class WK2.

Fixing material for drilled hole 1 – front

Mounting substructure	Designation of dowels	Min. depth of drilled hole	Screw (galvanised steel)
Concrete (C20/25 (B25))	SXR10/80 art. no. 702117	100 mm	Spax screw 5x100
Brickwork (honeycomb)	SXR10/80 art. no. 702117	100 mm	Spax screw 5x100
Sand lime brick, hollow brick	SXR10/80 art. no. 702117	100 mm	Spax screw 5x100

Fixing material for drilled hole 2 – lateral

Mounting substructure	Designation of dowels	Min. depth of drilled hole	Screw (galvanised steel)
Concrete (C20/25 (B25))	SXR10/80 art. no. 702117	100 mm	Wood screw 6x100 and washer DIN 125 A6.4
Brickwork (honeycomb)	SXR10/80 art. no. 702117	100 mm	Wood screw 6x100 and washer DIN 125 A6.4
Sand lime brick, hollow brick	SXR10/80 art. no. 702117	100 mm	Wood screw 6x100 and washer DIN 125 A6.4
Wooden window (as new)	–	–	Wood screw 6x40 and washer DIN 125 A6.4

Guide rails/end rail

Security roller shutter FR 23/FR 24

Guide rail

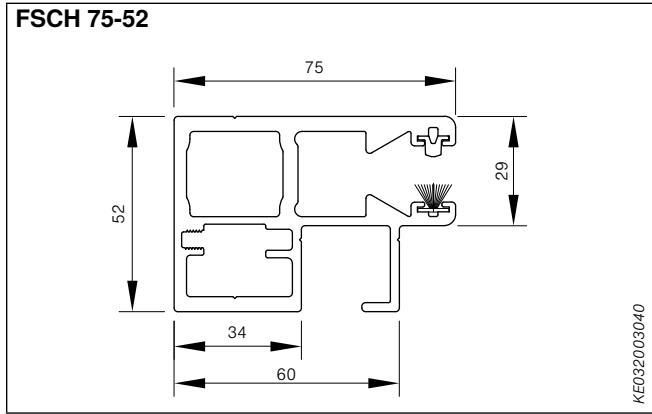

Fig. 96: Guide rail

End rail

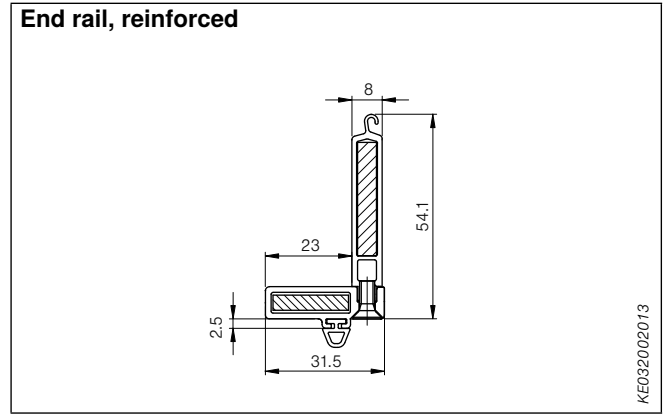

Fig. 97: End rail

Hooking in of roller shutter curtain and end rail (horizontal cross section)

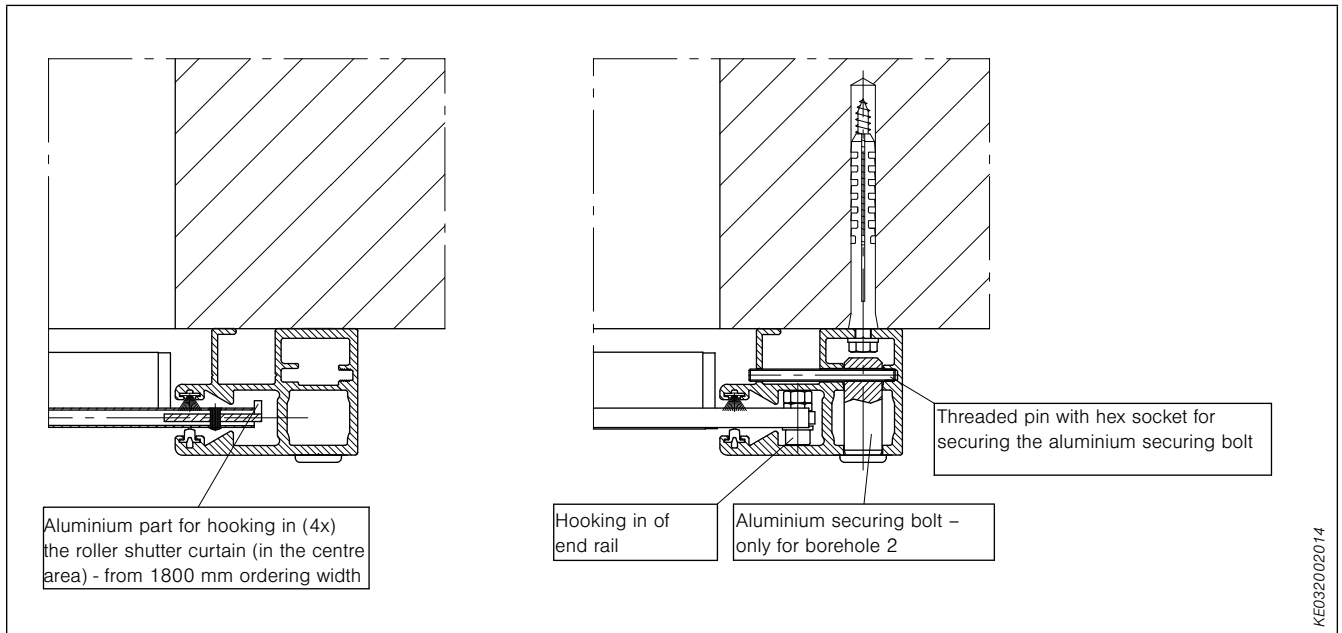

Fig. 98: Hooking in of roller shutter curtain and end rail

Certificate

Security roller shutter FR 23/FR 24

The current test certificate can be found at www.warema.com in the menu Products>Roller shutters>Security Roller Shutters.

Certificate



Die Anerkennung
umfasst nur das angegebene Bauteil/System in der zur Prüfung angegebenen Ausführung

- mit allen Unterlagen nach Anlage 1
- dokumentiert in der technischen Unterlagen nach Anlage 2
- zur Verwendung in den angegebenen Einrichtungen der Brandschutz- und Sicherungstechnik. Die bei Anwendung der Unterlagen der Anerkennung sind die Hinweise/Bemerkungen nach Anlage 3 zu beachten.

Die Gültigkeit der Anerkennung kann auf Antrag verlängert werden. Antrag auf Verlängerung ist spätestens 6 Monate vor Ablauf der Gültigkeit zu stellen.

Das Zertifikat darf für unveränderte und mit ähnlichen Anlagen verwendet werden. Alle Änderungen der Voraussetzungen für die Anerkennung sind der VdS Zertifizierungsstelle – zusammen mit erforderlichen Unterlagen – unverzüglich zu übermitteln.

Eine Werbung mit der VdS-Anerkennung des Produktes muss dem Inhalt des Zertifikates korrekt wiedergeben und darf nicht auf wettbewerbsrechtliche Art und Weise erfolgen.



Zertifikat

über die

Anerkennung

von

Bauteilen und Systemen

Hersteller der Anerkennung:

WAREMA Renkhoff SE
Hans-Wilhelm-Renkhoff-Straße 2
DE-97828 Marktheidenfeld

Anerkennungsnr.	Anzahl der Seiten	Gültig von	Gültig bis
M 196043	4	15.04.2010	14.04.2014

Gegenstand der Anerkennung:

Einbruchhemmendes Rollladenelement - Klasse N
Typ FR 23 / FR 24

Verweisung:

als mechanische Sicherungseinrichtung

Anerkennungsgrundlagen:

VdS 2344 : 2005-12, Verfahren für die Prüfung, Anerkennung und Konformitätsbewertung von Geräten, Bauteilen und Systemen der Brandschutz- und Sicherungstechnik

VdS 2841 : 2005-12, Durchführung von Produktüberwachungen

VdS 2534 : 1999-11, Richtlinien für mechanische Sicherungseinrichtungen, Einbruchhemmende Fassadenelemente, Anforderungen und Prüfmethoden

DIN V ENV 1627 : 1999-04, Fenster, Türen, Abschlüsse - Einbruchhemmung, Anforderungen und Klassifizierung



Köln, den 22. März 2010



Schüngel
Geschäftsführer



ppa. Urban
Leiter der Zertifizierungsstelle

VdS Schadenverhütung GmbH
Zertifizierungsstelle
Amsterdamer Str. 17d
D-50735 Köln

Ein Unternehmen des Gesamtverbandes der Deutschen Versicherungswirtschaft e.V. (GDV) akkreditiert als Zertifizierungsstelle für die Bereiche Brandschutz- und Sicherungstechnik von der Deutschen Akkreditierungsstelle Technik (DATech)

33640

Fig. 99: Certificate

Test certificate

Security roller shutter FR 23/FR 24

The current certificate can be found at www.warema.de in the menu Products>Roller shutters>Security Roller Shutters.

Test certificate





		PfB Prüfzentrum für Bauelemente Dipl.-Ing. (FH) Rüdiger Müller
		Fenster · windows Rolläden · shutters Türen + Tore · doors Fassaden · curtain walling Baubeschläge · building hardware
KURZBERICHT Nr. 05/03-A023-K1		
Einbruchhemmung nach DIN V ENV 1627 : 1999-04 „Fenster, Türen, Abschlüsse – Einbruchhemmung - Anforderungen und Klassifizierung“ für Rolläden in der Widerstandsklasse WK 2		
Antragsteller	WAREMA Renkhoff GmbH Vorderbergstraße 30 D-97828 Marktheidenfeld	
Bauart	Linksauffrollende Rollladen-Anlage mit Rollpanzer aus stranggepressten Aluminiumprofilen, verstärktem Endstab, Führungsschiene aus stranggepresstem Aluminiumprofil, gesicherter Rollkasten mit Hochschiebesicherung, elektrischer Antrieb oder innenliegende Handkurbel	
Produktbezeichnung	Sicherheitsrollladen Typ FR 23 (Vorbaukasten eckig) Sicherheitsrollladen Typ FR 24 (Vorbaukasten halbrund)	
Herstellungsgrößen	Breitenmaß	max. 2250 mm
	Höhenmaß	max. 2250 mm*
	Mindesttiefe der Führung	min. 75 mm
	Mindest Eintauchtiefe des Rollpanzers in die Führungsschiene	min. 35 mm
Angriffseite	Außenseite	
Schließzustand	geschlossen in Endlage	
Klassifizierung	Obige Bauart ist gemäß Prüfbericht Nr. 99/12-959 vom 01.12.1999 - ausgestellt vom PTE Rosenheim - sowie Gutachtliche Stellungnahme Nr. 05/03-A023-G1 vom 15.03.2005 - ausgestellt vom PfB - einbruchhemmend nach DIN V ENV 1627 : 1999-04 in der Widerstandsklasse WK 2. <small>Dieser Kurzbericht enthält nur eine Aussage über die Leistungseigenschaft der Einbruchhemmung gemäß DIN V ENV 1627 : 1999-04</small>	
Normbezeichnung	Rollladen DIN V ENV 1627 - WK 2	
Gültigkeit	Laufzeit der DIN V ENV 1627 Ausgabe April 1999	
	 Dipl.-Ing. (FH) Rüdiger Müller Institutsleiter	 15.03.2005
		 Dipl.-Ing. Matthias Demmel Sachbearbeiter
<small>Die Montageanleitung ist Bestandteil von Prüfbericht Nr. 99/12-959 vom 01.12.1999 und ist jedem gelieferten Bauelement beizulegen.</small>		
PfB Lackermannweg 24 D-93071 Stephanskirchen Institutsleiter Rüdiger Müller	Telefon +49 (0) 80 36 / 67 49 47 - 0 Telefax +49 (0) 80 36 / 67 49 47 - 26 Internet http://www.pfb-rosenheim.de e-mail: info@pfb-rosenheim.de	Sparkasse Rosenheim Bankleitzahl 711 500 00 Kontonummer 500 537 337 Steuer-Nr. 156/152/68002

Fig. 100: Test certificate

* According to the expert opinion of the test institute, the max. height of 2250 mm may be exceeded by 50% within the framework of the maximum construction limit values. This will not result in any limitations or reductions of the wind resistance classification. The expert opinion can be provided upon request.

Contents

Front-mounted external venetian blinds

Front-mounted external venetian blinds R6	134
Construction limit values	137
Box dimensions	138
Front-mounted external venetian blinds R10	140
Construction limit values	143
Box dimensions	145
Determining dimensions/order data	147
Adjusting/measuring insect screen	149
Insect screen swivel frame	150
Order data for combinations	152
Box extension	153
Additional box fastening	157
Tilting behaviour details	158
Operation details	163
Front-mounted external venetian blinds R6/R10 Solar	167

Description

Front-mounted external venetian blinds R6

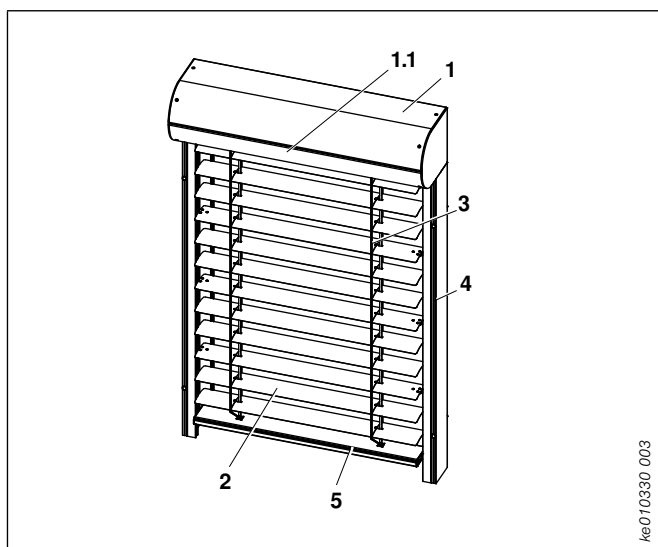

Fig. 101: Front-mounted external venetian blinds

- 1 Box**
 - 1.1 Inspection cover**
- 2 Slats**
 - 2.1 Beaded slats**
 - 2.2 Flat slats**
 - 2.3 Dim-out slats**
- 3 Ladder tape/lift tape**
- 4 Lateral guidance**
- 5 Bottom rail**

Application

Can be used for retrofitting but also for new buildings and renovations.

Installation note:

Both with individual and coupled front-mounted external venetian blind systems, the slat stack is preinstalled in the box.

Operation

Motor

The slats are raised and lowered as well as tilted by actuating an operating switch.

Voltage: 230 V AC, other voltages optional

Frequency: 50 Hz, other frequencies optional

Protection rating: IP 54

Dowel-in connector: Hirschmann coupling

Shaft outlet on both sides.

Upon reaching the upper or lower limit position the drive switches off using built-in, adjustable limit switches.

Solar drive (optional)

Operation: via electric drive with hand-held radio transmitter

Voltage: 12 V

Protection rating: IP 54

Cover panel depth: min. 150 mm

Solar panel mounted externally on the box, external panel optional

Crank

The slats are raised and lowered as well as tilted with the crank.

Crank rod with collapsible crank; sealed joint plate and square with thermal separation.

Material: aluminium

Surface: C0 anodised, optionally powder-coated in RAL 9016 or anodised C34

Crank holder: plastic, grey, white or brown, crank holder with magnet optional

Box (1)

4 box shapes, 2 box sizes, closed on 3 or 3 sides (box shape plaster)

Box shapes: rectangular, round, square, plaster

Material: aluminium, extruded

Material thickness: 3 mm

Dimensions: see table

Surface: powder-coated, anodising optional

Lateral bottom parts: aluminium, diecast

Plaster squares: standard 26 mm and 13 mm (surcharge)

Maximum box width: 4000 mm

Plaster model with 8 mm polystyrene sheet as plaster base plate

When using plaster elements the box of the external venetian blind can be embedded in plaster up to 15 mm (with plaster version Standard).

Inspection cover (1.1)

Material: aluminium, extruded

Surface: powder-coated, anodising optional

Material thickness: 3 mm

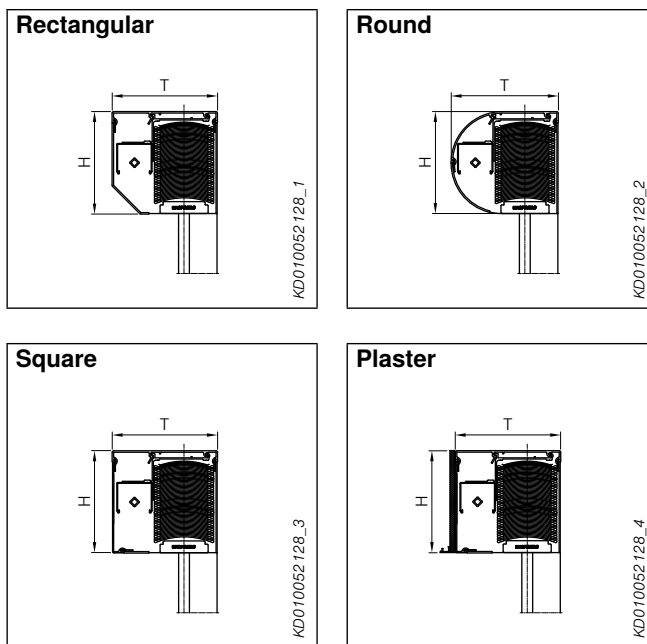

Fig. 102: Box types

Description

Front-mounted external venetian blinds R6

Box dimensions in mm

Box size	R6 E (H x D)	R6 R (H x D)	R6 Q/R6 P (H x D)
16.5	171 x 175	170 x 178	170 x 175
18.5	190 x 194	189 x 197	189 x 194

Top rail

Material: aluminium, extruded
Material thickness: 1.5 mm
Dimensions (w x h): 59 x 51 mm
Profile: C profile
Surface: plain
Fixing: with aluminium brackets, plain

Tilt rod

Material: steel, zinc-coated
Material thickness: 1 mm
Dimensions (w x h): 12 x 12 mm
Profile: square tube
Surface: plain

Bearing

maintenance-free, enclosed
Enclosure: plastic, with Teflon
Tilting roller: plastic
Tape reel: plastic
Segment tilting to prevent self-acting adjustment of slats.

Slats (2)

Beaded slats (2.1)

Edges beaded on both sides, curved
Material: aluminium, special alloy
Material thickness: approx. 0.44 mm
Dimensions (w): 80 mm
Installation: convex
Surface: enamel finish, resistant to corrosion using a special process
Colour: according to WAREMA colour chart for external venetian blinds

All perforations in the slats have black eyelets to guide the lift tapes (reduction of abrasion) and fix the webs of the ladder tape.

The blind moves down with the slats closed to the outside and moves up with the slats closed to the inside.

Flat slats (2.2)

Curved flat slat, no eyelets
Material: aluminium, special alloy
Material thickness: approx. 0.45 mm
Dimensions (w): 80 mm
Profile: convex
Surface: enamel finish, resistant to corrosion using a special process
Colour: according to WAREMA colour chart for external venetian blinds

The top slat is reinforced and equipped with black eyelets (to reduce abrasion).

Optionally all slats are available with protective eyelets.

The blind descends with the slats closed to the outside and moves up with slats tilted approx. 55° to the inside.

Dim-out slats (2.3)

edges beaded on both sides, special profile
Material: aluminium, special alloy
Material thickness: approx. 0.45 mm
Dimensions (w): 73 mm
Profile: special profile, front beading with sealing strip made from flexible plastic
Surface: enamel finish, resistant to corrosion using a special process
Colour: according to WAREMA colour chart for external venetian blinds

All edges of the perforations in the slats are continuously beaded in order to reduce wear of the lift tape to a minimum. The external venetian blind moves down with closed slats and up with horizontal slats.

Ladder tape/lift tape (3)

Ladder tapes (3.1)

Special heavy-duty version with double webs
Material: polyester, with Kevlar core
Colour: black, optionally grey
Each slat is fixed to the upper web of the ladder tape. On the model with dim-out slats, the loop cord is tied to the slat with stainless steel clips.

Lift tapes (3.2)

Material: polyester, with special coating
Colour: black, optionally grey

Lateral guidance (4)

Front-mounted rails
with black piping inserted for noise reduction
Material: aluminium, extruded
Dimensions (w x h): guide rails 25x18 mm
overall 39x64 mm
Fixing: directly screw-fixed on the window profile
Surface: powder-coated, anodising optional
End cap: plastic, black, optionally grey
Sealing strip: weather-proof, UV stable, black
Guiding nipple: Polyamide, glass fibre reinforced, impact-resistant connection with the slats. Slats with alternating nipples (beaded slats and dim-out slats), every 3rd slat nipped on both sides (flat slat).

Description

Front-mounted external venetian blinds R6

Bottom rail (5)

with end caps

Material: aluminium, extruded

Dimensions (w x h): 73/80x20 mm

Surface: powder-coated, anodising optional

End caps: plastic, black, optionally grey

Bottom rail for rail guidance A6 with movable guiding nipples with slotted end caps to prevent the curtain from unhinging.

Colours

Powder coating of aluminium parts with chrome-free pre-treatment in accordance with valid RAL CLASSIC colour chart (except camouflage and luminous colours) or in DB colours 701, 702 and 703 as well as eight textured colours (W4914 - W4921), four anodised-look colours (WC31 - WC34) and further colours according to WAREMA standard colour fan (in WAREMA colour specification).

Other colour specifications and special colours are available upon request and at a surcharge.

Construction limit values

Front-mounted external venetian blinds R6

You can also use our free planning program at www.sonnenschutzplaner.de for planning the sun shading systems – configure the product and generate a technical drawing that can be integrated into your plans.

For further installation examples for different wall structures for use in consultations please see our external venetian blinds brochure, art. no. 115201.

Construction limit values in mm

Box sizes R6	Types	Individual units					Combination			
		Width		Height			Surface area ¹⁾ in m ²	Width	Surface area ¹⁾ in m ²	Number of curtains
		min. ²⁾	max.	max. ³⁾	without protrusion	approx. protrusion per 100 mm add. height in mm				
16.5	C 80 AFA6	680	4000	4000	2750	3	7.0	6000	13.0	3
	E 80 AFA6	680	4000	4000	3550	3	16.0	6000	24.0	3
	C 80 AFA6 with eyelets	680	4000	4000	2450	3	7.0	6000	13.0	3
	E 80 AFA6 with eyelets	680	4000	4000	3600	3	16.0	6000	24.0	3
	E 80 A6 ⁴⁾	680	4000	4000	2600	5	16.0	6000	24.0	3
	E 73 A6	680	4000	4000	2180	6	15.0	6000	24.0	3
18.5	C 80 AFA6	680	4000	4000	3400	3	7.0	6000	13.0	3
	E 80 AFA6	680	4000	4000	4000		16.0	6000	24.0	3
	C 80 AFA6 with eyelets	680	4000	4000	3050	3	7.0	6000	13.0	3
	E 80 AFA6 with eyelets	680	4000	4000	4000		16.0	6000	24.0	3
	E 80 A6 ⁵⁾	680	4000	4000	3000	5	16.0	6000	24.0	3
	E 73 A6	680	4000	4000	2560	6	15.0	6000	24.0	3

¹⁾ Solar drive up to max. 5 m² curtain area, max. 2600 mm curtain height. Curtain coupling and R6 Plaster model not possible. Unit heights without protruding bottom rail according to table R10 with insect screen roller blind, construction limit values according to construction limit value diagram Page 167 ff.

²⁾ Width = slat dimension. Solar drive min. width 760 mm.

³⁾ Maximum height for models with daylight transport element 3000 mm

⁴⁾ From an ordered height of 1950 mm with offset slat stack.

⁵⁾ From an ordered height of 2250 mm with offset slat stack.

For types 80 AF A6 a tensioning cable must be used in the centre of the curtain for wind protection from an ordered width of 2400 mm.

Notes:

- The indicated maximum area in m² depend on the individual height (see „Height-to-width ratio for external venetian blinds“ on page 28). All other dimensions are subject to individual clarification with the Application Technology department!
- For external venetian blinds with equipment variant vivamatic® or slowturn the construction limit values of the corresponding basic type should be assumed. Max. 3 curtains are possible here as a coupled unit with one drive.

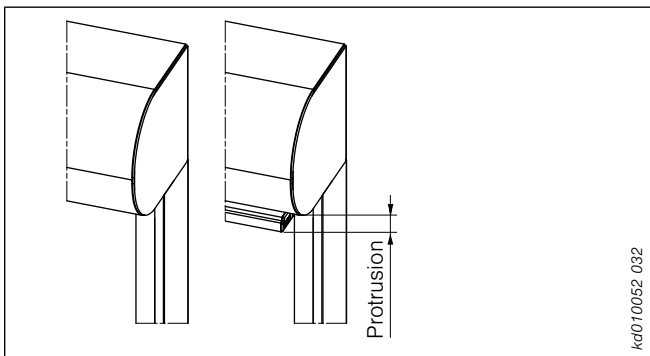

Fig. 103: Protrusion of the bottom rail

Tolerances

Slat stack height: ±10 mm

Stack parallelism with retracted blind: ±10 mm

Additional box fastening for elements set in plaster

From order widths over 1500 mm we recommend additional box fastening (see fig. 137 on page 157).

Box dimensions

Front-mounted external venetian blinds R6

Box sizes

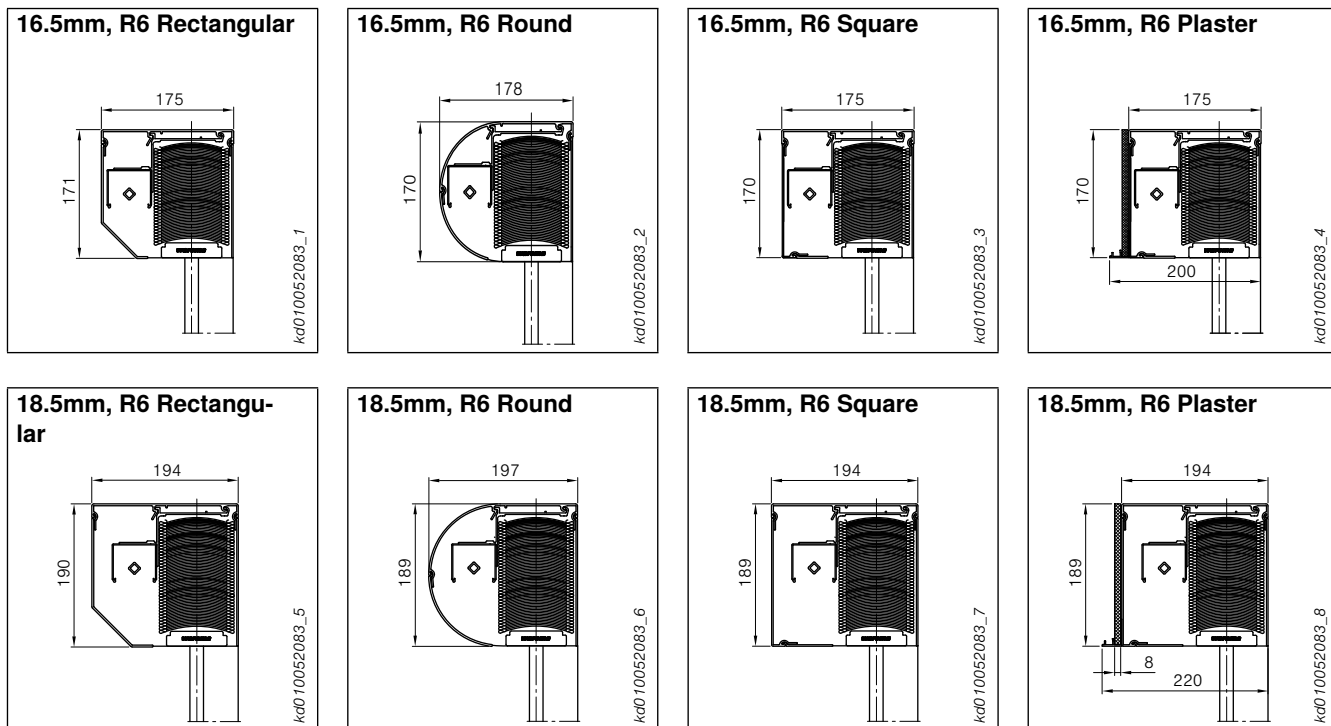

Fig. 104: Box sizes

Guide rails without insect screen

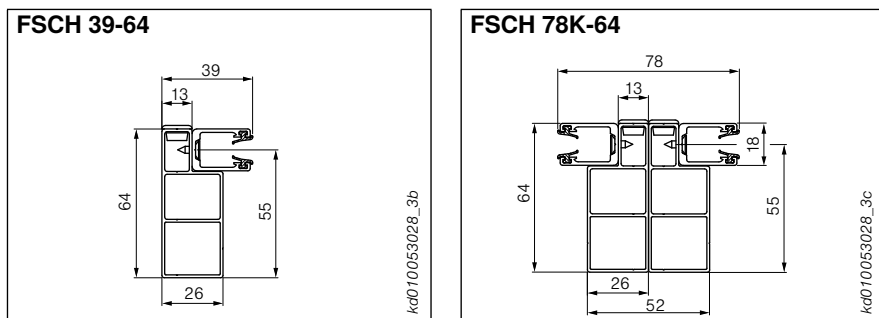

Fig. 105: Guide rails without insect screen



Fig. 106: Aluminium end cap for guide rail (optional)

Fixing boreholes in the front-mounted rails

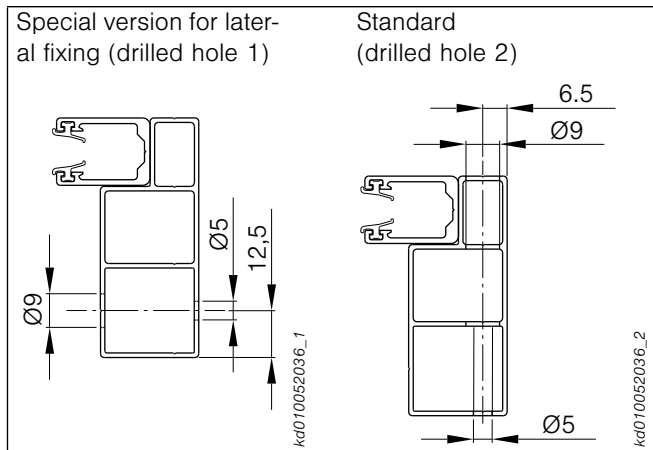

Fig. 107: Fixing boreholes

Number of fixing bore holes

Front-mounted rail length	Quantity
up to 1350	2
1351 to 2400	3
2401 to 3450	4
3451 to 4000	5

Position of holes for drilled hole type 2

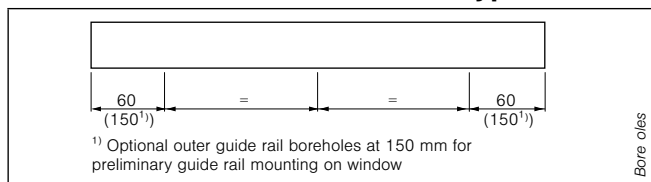

Fig. 108: Position of holes for drilled hole type 2

Control systems	Accessories Roller shutter curtains	Front-mounted external Venetian blinds	Security roller shutters	Guide and end rails	Additional options	Determining dimensions/operating details	Front-mounted roller shutters V10	Front-mounted roller shutters V6	Front-mounted roller shutters V4	Overview
-----------------	--	---	--------------------------	---------------------	--------------------	--	--------------------------------------	-------------------------------------	-------------------------------------	----------

Description

Front-mounted external venetian blinds R10

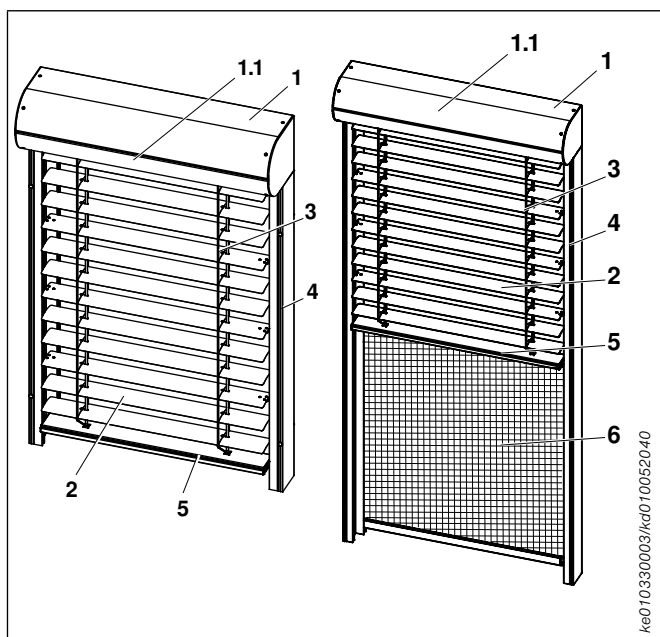

Fig. 109: Front-mounted external venetian blinds

1 Box

1.1 Inspection cover

2 Slats

2.1 Beaded slats

2.2 Flat slats

2.3 Dim-out slats

3 Ladder tape/lift tape

4 Lateral guidance

5 Bottom rail

6 Insect screen (optional)

6.1 Insect screen roller blind

6.2 Insect screen swivel frame

Application

Can be used for retrofitting but also for new buildings and renovations.

Installation note:

Both with individual and coupled front-mounted external venetian blind systems, the slat stack is preinstalled in the box.

Operation

Motor

The slats are raised and lowered as well as tilted by actuating an operating switch.

Voltage: 230 V AC, other voltages optional

Frequency: 50 Hz, other frequencies optional

Protection rating: IP 54

Dowel-in connector: Hirschmann coupling

Shaft outlet on both sides.

Upon reaching the upper or lower limit position the drive switches off using built-in, adjustable limit switches.

Solar drive (optional)

Operation: via electric drive with hand-held radio transmitter

Voltage: 12 V

Protection rating: IP 54

Cover panel depth: min. 150 mm

Solar panel mounted externally on the box, external panel optional

Crank

Crank rod with collapsible crank; sealed joint plate and square with thermal separation.

Material: aluminium

Surface: C0 anodised, optionally powder-coated in RAL 9016 or anodised C34

Crank holder: plastic, grey, white or brown, crank holder with magnet optional

Box (1)

4 box shapes, 2 box sizes, closed on 3 or 3 sides (box shape Plaster)

Box shapes: rectangular, round, square, plaster

Material: aluminium, extruded

Material thickness: 3 mm

Dimensions: see table

Surface: powder-coated, anodising optional

Lateral bottom parts: aluminium, diecast

Plaster squares: standard 26 mm and 13 mm (surcharge)

Maximum box width: 4000 mm

Plaster model with 8 mm polystyrene sheet as plaster base plate

When using plaster elements the box of the external venetian blind can be embedded in plaster up to 15 mm (with plaster version Standard).

Inspection cover (1.1)

Material: aluminium, extruded

Surface: powder-coated, anodising optional

Material thickness: 3 mm

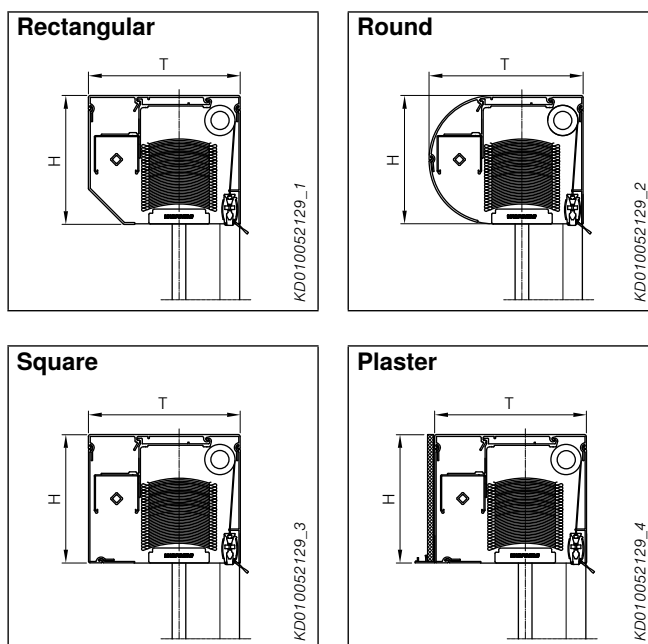

Fig. 110: Box types

Description

Front-mounted external venetian blinds R10

Box dimensions in mm

Box size	R10 E (HxD)	R10 R (HxD)	R10 Q/R10 P (HxD)
16.5	171 x 201	170 x 204	170 x 201
18.5	190 x 220	189 x 223	189 x 220

Top rail

Material:	aluminium, extruded
Material thickness:	1.5 mm
Dimensions (w x h):	59 x 51 mm
Profile:	C profile
Surface:	plain
Fixing:	with aluminium brackets, plain

Tilt rod

Material:	steel, zinc-coated
Material thickness:	1 mm
Dimensions (w x h):	12 x 12 mm
Profile:	square tube
Surface:	plain

Bearing

maintenance-free, enclosed	
Enclosure:	plastic, with Teflon
Tilting roller:	plastic
Tape reel:	plastic
Segment tilting to prevent self-acting adjustment of slats.	

Slats (2)

Beaded slats (2.1)

Edges beaded on both sides, curved	
Material:	aluminium, special alloy
Material thickness:	approx. 0.44 mm
Dimensions (w):	80 mm
Installation:	convex
Surface:	enamel finish, resistant to corrosion using a special process
Colour:	according to WAREMA colour chart for external venetian blinds

All perforations in the slats have black eyelets to guide the lift tapes (reduction of abrasion) and fix the webs of the ladder tape.

The blind moves down with the slats closed to the outside and moves up with the slats closed to the inside.

Flat slats (2.2)

Curved flat slat, no eyelets	
Material:	aluminium, special alloy
Material thickness:	approx. 0.45 mm
Dimensions (w):	80 mm
Profile:	convex
Surface:	enamel finish, resistant to corrosion using a special process
Colour:	according to WAREMA colour chart for external venetian blinds

The top slat is reinforced and equipped with black eyelets (to reduce abrasion).

Optionally all slats are available with protective eyelets.

Slats with special perforation to lock the ladder tape. The blind moves down with the slats closed to the outside and moves up with slats tilted approx. 55° to the inside.

Dim-out slats (2.3)

edges beaded on both sides, special profile	
Material:	aluminium, special alloy
Material thickness:	approx. 0.45 mm
Dimensions (w):	73 mm
Profile:	special profile, front beading with sealing strip made from flexible plastic
Surface:	enamel finish, resistant to corrosion using a special process
Colour:	according to WAREMA colour chart for external venetian blinds

All edges of the perforations in the slats are continuously beaded in order to reduce wear of the lift tape to a minimum. The external venetian blind moves down with closed slats and up with horizontal slats.

Ladder tape/lift tape (3)

Ladder tapes (3.1)

Special heavy-duty version with double webs	
Material:	polyester, with Kevlar core
Colour:	black, optionally grey
Each slat is fixed to the upper web of the ladder tape.	
On the model with dim-out slats, the loop cord is tied to the slat with stainless steel clips.	

Lift tapes (3.2)

Material:	polyester, with special coating
Colour:	black, optionally grey

Lateral guidance (4)

Front-mounted rails

with black piping inserted for noise reduction	
Material:	aluminium, extruded
Dimensions (w x h):	guide rails 25x18 mm overall 39x89 mm
Fixing:	directly screw-fixed on the window profile
Surface:	powder-coated
End cap:	plastic, black, optionally grey
Sealing strip:	weather-proof, UV stable, black
Guiding nipple:	Polyamide, glass fibre reinforced, impact-resistant connection with the slats. Slats with alternating nipples (beaded slats and dim-out slats), every 3rd slat nipped on both sides (flat slat).

The rails for the insect screen are already integrated into the front-mounted rails or optional.

Description

Front-mounted external venetian blinds R10

Bottom rail (5)

with end caps

Material: aluminium, extruded
Dimensions (w x h): 73/80x20 mm
Surface: powder-coated, anodising optional
End caps: plastic, black, optionally grey
Bottom rail for rail guidance A6 with movable guiding nipples with slotted end caps to prevent the curtain from unhinging.

Insect screen (6) (optional)

Insect screen roller blind (6.1)

Insect screen roller blind for vertical mounting between sun shading curtain and window.

Operation: with handle rail, handle rails is fixed by clicking in special labyrinth locking, handle shell optional. The handle shell is installed in the handle rail towards the outside (optionally to the inside)

Curtain

Material: gauze from plastic coated fibre glass fabric

Colours: grey, optionally black

Profiles

Material: aluminium, extruded
Surface: powder-coated
Dimensions (w x h): guide rails 24x34 mm
handle rail 17x40 mm
Brush sealing strip: brush sealing strip in handle rail and guide rail
Retrofitting kit: for easy mounting in the existing external venetian blind/roller shutter unit. Consists of gauze on the shaft with integrated spring mechanism, handle rail and two guide rails

Insect screen swivel frame (6.2)

Models with 1 or 2 wings with continuous mounting frame. The swivel frame opens outwards. Includes integrated closing aid and continuous brush sealing strip.

Operation: Up to a frame height of 1800 mm with handle, from frame height of 1801 mm with horizontal bar with integrated handle rail.

Curtain

Material: gauze from plastic coated fibre glass fabric

Colours: grey, optionally black highly transparent

Profiles

Material: aluminium, extruded
Surface: powder-coated
Dimensions (w x h): frame profile 12.5 x 30 mm and 12.5 mm x 28 mm horizontal bar with integrated handle rail 10 x 52 mm

Plastic parts

Colours: white, grey or black

Colours

Powder coating of aluminium parts with chrome-free pre-treatment in accordance with valid RAL CLASSIC colour chart (except camouflage and luminous colours) or in DB colours 701, 702 and 703 as well as eight textured colours (W4914 - W4921), four anodised-look colours (WC31 - WC34) and further colours according to WAREMA standard colour fan (in WAREMA colour specification). Other colour specifications and special colours are available upon request and at a surcharge.

Construction limit values

Front-mounted external venetian blinds R10

You can also use our free planning program at www.sonnenschutzplaner.de for planning the sun shading systems – configure the product and generate a technical drawing that can be integrated into your plans.

For further installation examples for different wall structures for use in consultations please see our external venetian blinds brochure, art. no. 115201.

Construction limit values in mm

Box size Combi (with insect screen roller blind) R10	Types	Individual units					Combination			
		Width ¹⁾		Height			Surface area ²⁾ in m ²	Width	Surface area ²⁾ in m ²	Number of cur- tains
		min.	max.	max. ^{2) 3)}	without pro- trusion	approx. pro- trusion per 100 mm add. height in mm				
16.5	C 80 AFA6	760	2000	2500	2500		5.0	6000	13.0	3
	E 80 AFA6	760	2000	2500	2500		5.0	6000	15.0	3
	C 80 AFA6 with eyelets	760	2000	2500	2450	3	5.0	6000	13.0	3
	E 80 AFA6 with eyelets	760	2000	2500	2500		5.0	6000	15.0	3
	E 80 A6 ⁴⁾	760	2000	2500	2100	5	5.0	6000	15.0	3
	E 73 A6	760	2000	2500	1710	6	5.0	6000	15.0	3
18.5	C 80 AFA6	760	2000	2500	2500		5.0	6000	13.0	3
	E 80 AFA6	760	2000	2500	2500		5.0	6000	15.0	3
	C 80 AFA6 with eyelets	760	2000	2500	2500		5.0	6000	13.0	3
	E 80 AFA6 with eyelets	760	2000	2500	2500		5.0	6000	15.0	3
	E 80 A6 ⁵⁾	760	2000	2500	2500		5.0	6000	15.0	3
	E 73 A6	760	2000	2500	2090	6	5.0	6000	15.0	3

¹⁾ Width = slat dimension

²⁾ Solar drive up to max. 5 m² curtain area, max. 2600 mm curtain height. Curtain coupling and R10 plaster model not possible. Unit heights without protruding bottom rail according to table R10 with insect screen roller blind, construction limit values according to construction limit value diagram Page 167 ff.

³⁾ Maximum height for models with daylight transport element 3000 mm

⁴⁾ From an ordered height of 1500 mm with offset slat stack.

⁵⁾ From an ordered height of 1850 mm with offset slat stack.

Box size Combi (with- out insect screen roller blind) R10	Types	Individual units					Combination			
		Width		Height			Surface area ³⁾ in m ²	Width	Surface area ³⁾ in m ²	Number of cur- tains
		min. ^{1) 2)}	max.	max. ^{3) 4)}	without pro- trusion	approx. pro- trusion per 100 mm add. height in mm				
16.5	C 80 AFA6	680	4000	4000	2750	3	7.0	6000	13.0	3
	E 80 AFA6	680	4000	4000	3550	3	16.0	6000	24.0	3
	C 80 AFA6 with eyelets	680	4000	4000	2450	3	7.0	6000	13.0	3
	E 80 AFA6 with eyelets	680	4000	4000	3600	3	16.0	6000	24.0	3
	E 80 A6 ⁵⁾	680	4000	4000	2600	5	16.0	6000	24.0	3
	E 73 A6	680	4000	4000	2180	6	15.0	6000	24.0	3
18.5	C 80 AFA6	680	4000	4000	3400	3	7.0	6000	13.0	3
	E 80 AFA6	680	4000	4000	4000		16.0	6000	24.0	3
	C 80 AFA6 with eyelets	680	4000	4000	3050	3	7.0	6000	13.0	3
	E 80 AFA6 with eyelets	680	4000	4000	4000		16.0	6000	24.0	3
	E 80 A6 ⁶⁾	680	4000	4000	3000	5	16.0	6000	24.0	3
	E 73 A6	680	4000	4000	2560	6	15.0	6000	24.0	3

¹⁾ When retrofitting insect screen roller blind minimum width 760 mm.

²⁾ Width = slat dimension. Solar drive min. width 760 mm.

³⁾ Solar drive up to max. 5 m² curtain area, max. 2600 mm curtain height. Curtain coupling and R10 plaster model not possible. Unit heights without protruding bottom rail according to table R10 with insect screen roller blind, construction limit values according to construction limit value diagram Page 167 ff.

⁴⁾ Maximum height for models with daylight transport element 3000 mm

⁵⁾ From an ordered height of 1950 mm with offset slat stack.

⁶⁾ From an ordered height of 2250 mm with offset slat stack.

Notes:

- The indicated maximum area in m² depend on the individual height (see „Height-to-width ratio for external venetian blinds“ on page 28). All other dimensions are subject to individual clarification with the Application Technology department!
- For external venetian blinds with equipment variant vivamatic® or slowturn the construction limit values of the corresponding basic type should be assumed. Max. 3

curtains are possible here as a coupled unit with one drive.

Construction limit values

Front-mounted external venetian blinds R10

For types 80 AFA6 a tensioning cable must be used in the centre of the curtain for wind protection from an ordered width of 2400 mm.

Units exceeding the construction limit values for models with insect screen cannot be retrofitted with an insect screen roller blind.

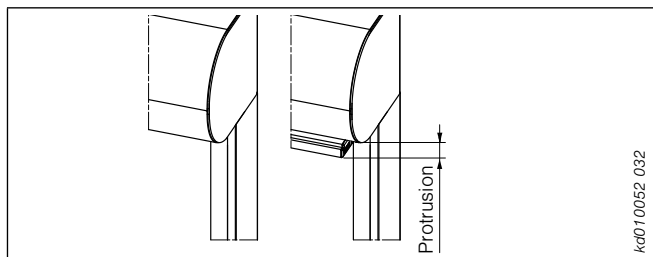

Fig. 111: Protrusion of the bottom rail

Tolerances

Slat stack height: ± 10 mm

Stack parallelism with retracted blind: ± 10 mm

Construction limit values with insect screen swivel frame in mm

(element dimensions front-mounted external venetian blind R10)

R10	Width		Height ¹⁾		Area (m ²)
	min.	max.	min.	max.	
one-wing	500	1300	700	2500	2.7
two-wing	1000	2600	700	2500	5.4

¹⁾ From ordering heights over 1900 mm a kick plate and a bar are included in the standard delivery; if no dimension "W" is specified, the bar will be positioned centrally in the insect screen swivel frame.

Box dimensions

Front-mounted external venetian blinds R10

Box sizes

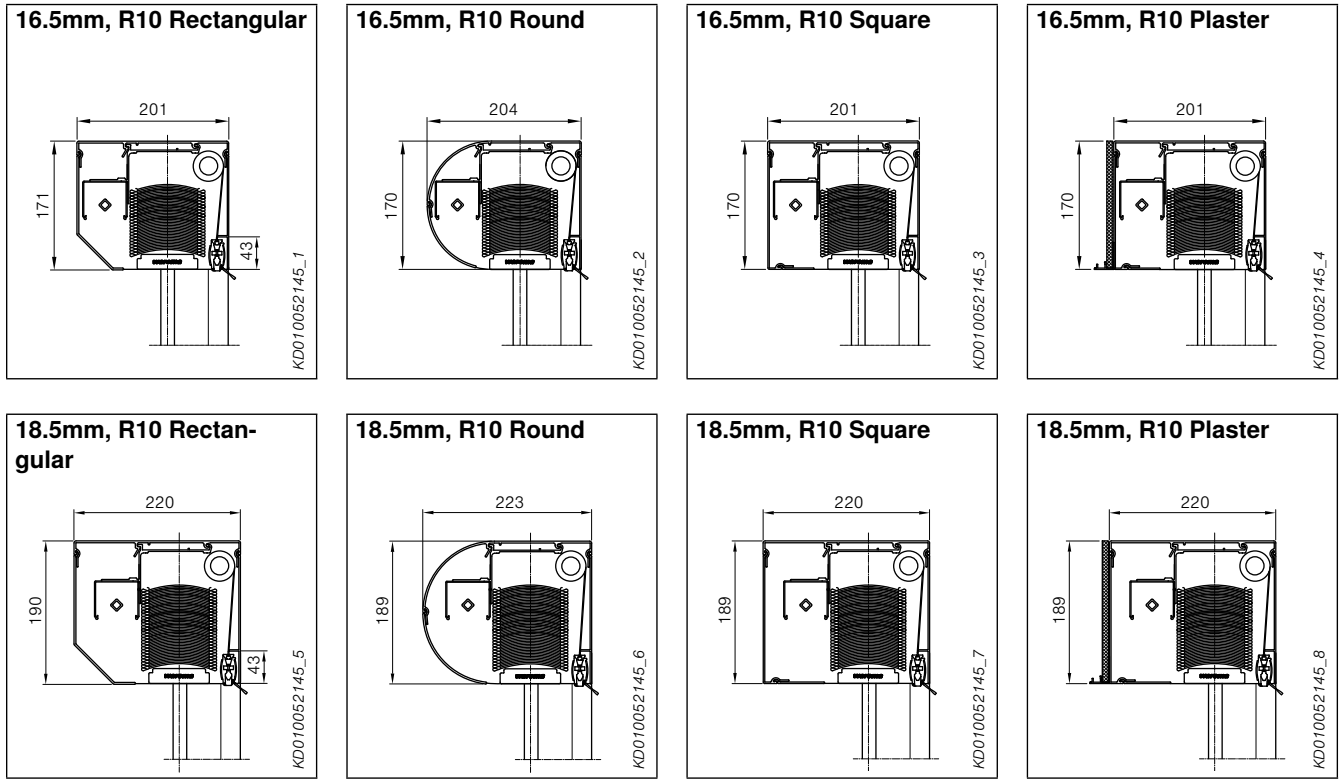

Fig. 112: Box sizes

Guide rails without insect screen

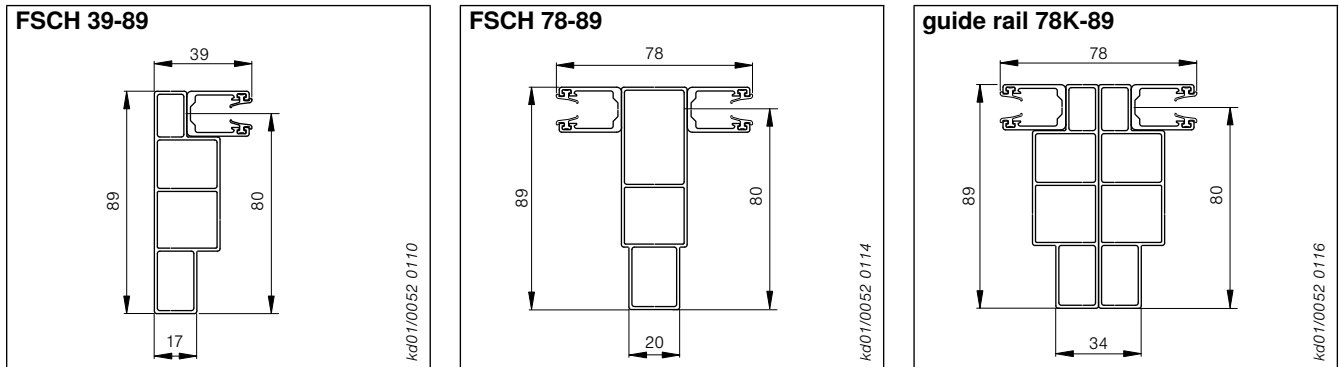

Fig. 113: Guide rails without insect screen

Guide rails with insect screen

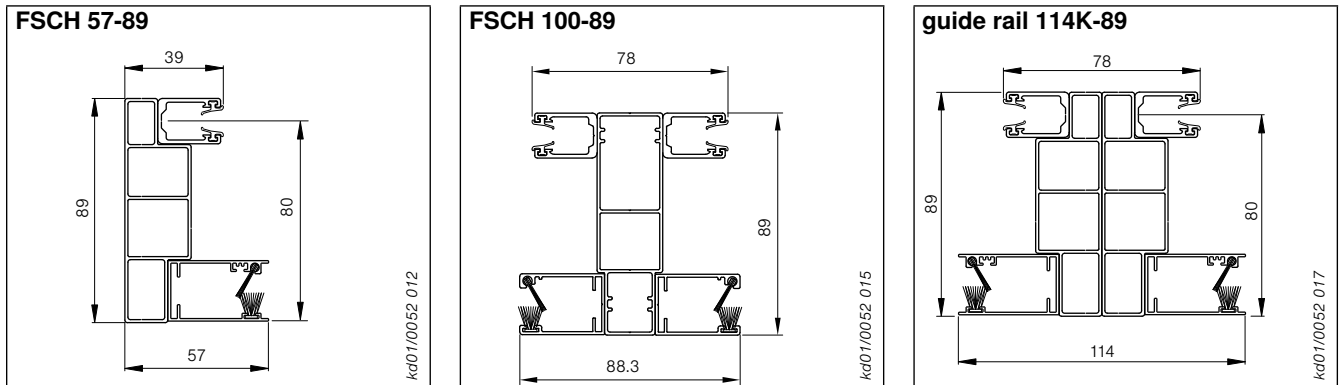

Fig. 114: Guide rails with insect screen

Guide rails

Front-mounted external venetian blinds R10

Fixing boreholes in the front-mounted rails

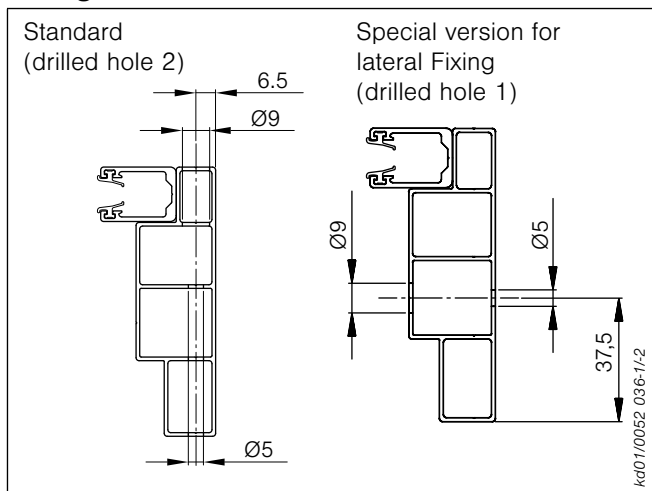

Fig. 115: Fixing bore holes

Aluminium end cap for guide rail (optional)



Fig. 116: Aluminium end cap for guide rail (optional)

Number of fixing bore holes

Front-mounted rail length	Quantity
up to 1350	2
1351 to 2400	3
2401 to 3450	4
3451 to 4000	5

Position of holes for drilled hole type 2

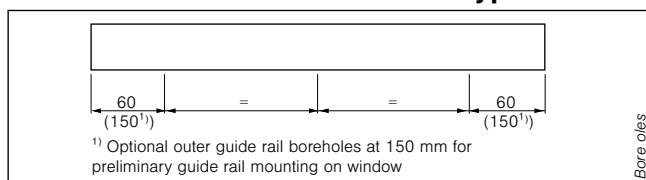

Fig. 117: Position of holes for drilled hole type 2

Suggestions for fixing the front-mounted rails

Substructure	Drilled hole (installation in the window frame)		Drilled hole in reveal		Hole diameter (mm)	Head diameter (mm)	
	Art. no.	DIN	Art. no.	DIN			
Aluminium/PVC with steel core	746151	DIN 912-A2 C4.8x70	746150	DIN 912-A2 C48x45	4	8.5	Hexagon socket screw size 4 ¹⁾
Wood	728035	DIN 7996-A2 4.5 x 70	728011	DIN 7996-A2 4.5 x 40	3.5	8.3	Cross-head ¹⁾
Masonry	740014	DIN 7996-A2 4.5 x 90	728035	DIN 7996-A2 4.5 x 70	6	8.3	Cross-head ¹⁾
	702096	Dowel SX 6L	702096	Dowel SX 6L			
PVC/aluminium	720295	Drilling oval head screw N 4.8x80 ²⁾				8.5	Torx T25 ¹⁾

¹⁾ Bits/screw drivers with min. 120 mm length are required for these screws! These are not included in the delivery.

²⁾ Drilling oval-head screw only optional – please state when ordering!

Additional box fastening (subject to surcharge)

From order widths over 1500 mm we recommend additional box fastening (see fig. 137 on page 157).

Note:

The WAREMA Fixing Guide provides a calculation tool which helps you to individually calculate the suitable and permitted fixing material for your application.

The WAREMA Fixing Guide is available at <http://befestigungsberater.warema.de>.

Determining dimensions/order data

Front-mounted external venetian blinds R6/R10

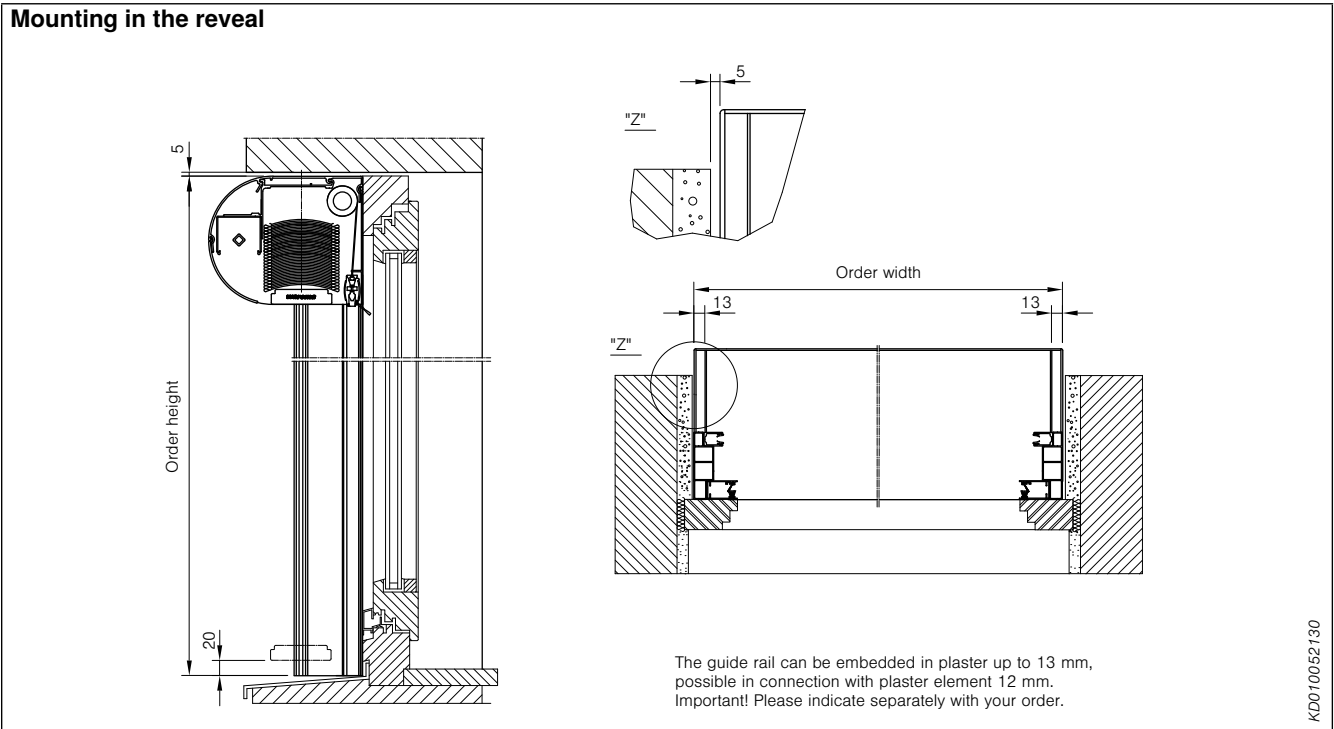

Fig. 118: Mounting in the reveal

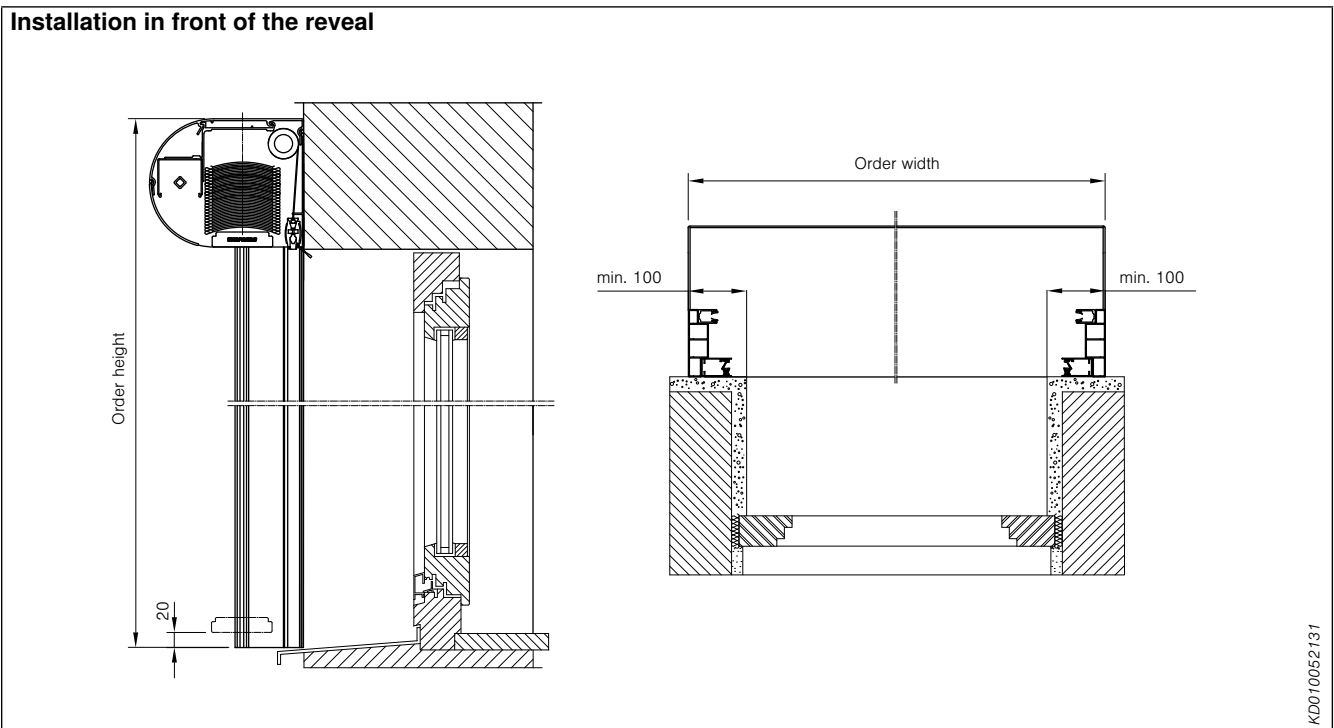

Fig. 119: Installation in front of the reveal

Important! This requires increased attention to the suitability of the substructure for mounting.

Determining dimensions/order data

Front-mounted external venetian blinds R6/R10

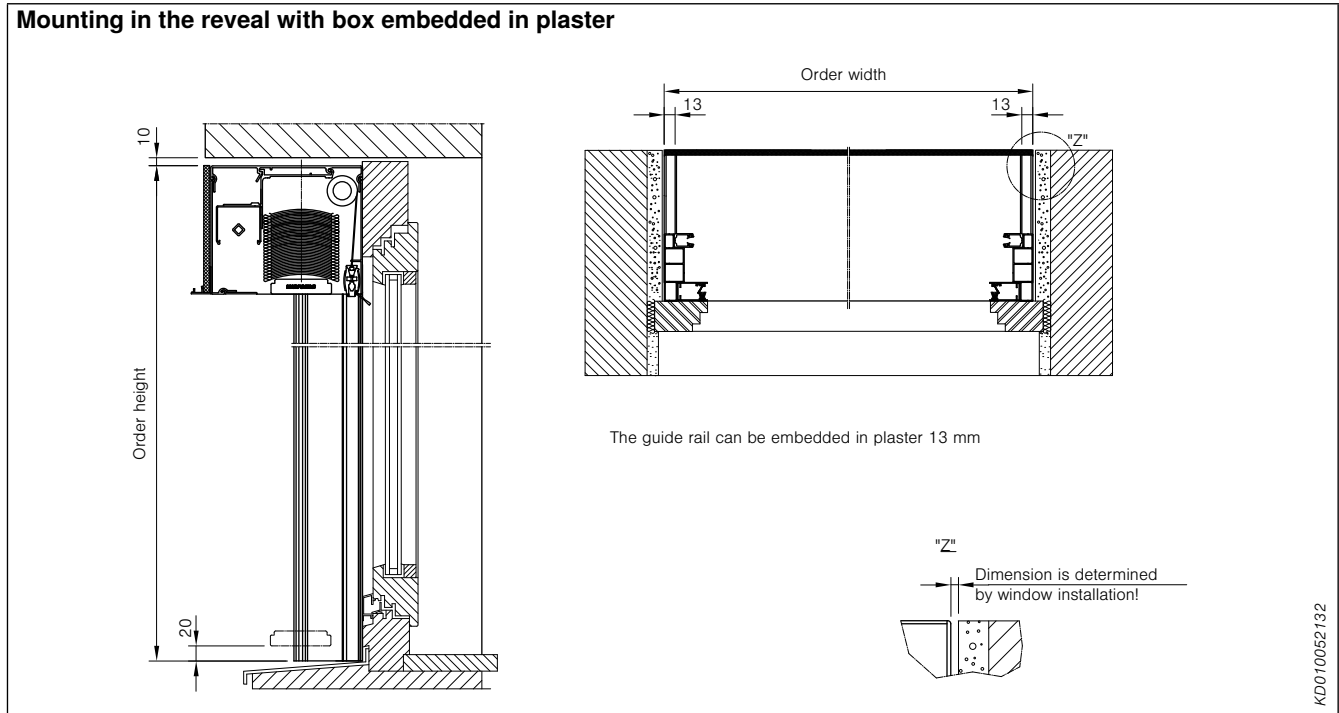

Fig. 120: Mounting in the reveal with box embedded in plaster

The details are general planning suggestions showing the construction of a wall structure. The illustration does not relieve the client from his obligation to carry out an individual examination of applicability and completeness for the building project in question. Adjacent constructions are only schematic representations. All specifications and assumptions

are to be adjusted to the circumstances on site and coordinated. Plaster and/or reinforcement connections of the plaster base profile sheet to existing insulation/masonry is to be designed according to DIN.

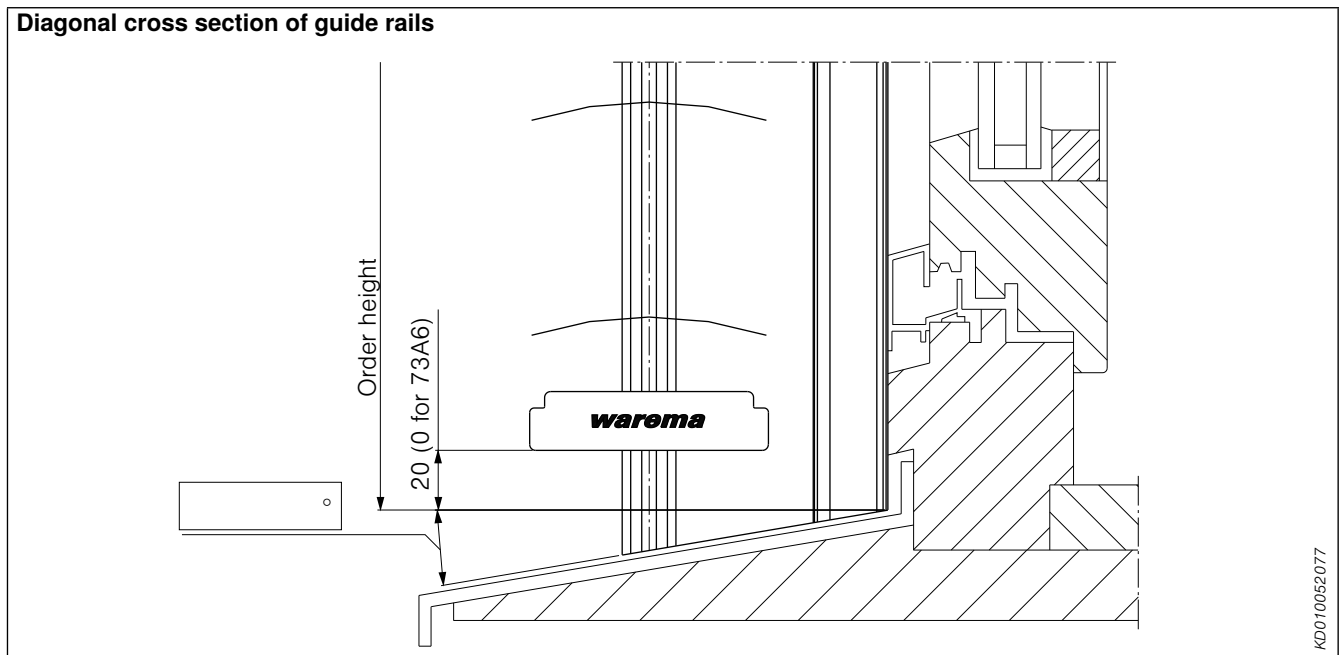
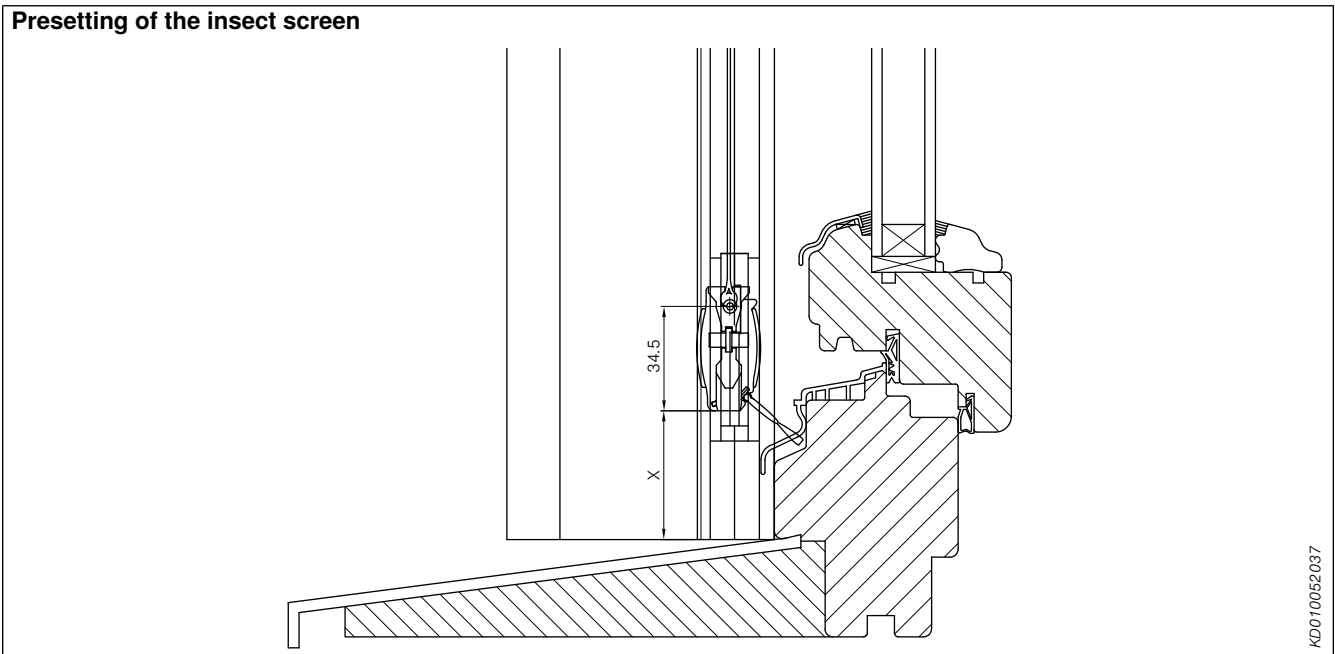

Fig. 121: Diagonal cross section of guide rails

Please state order height and inclination angle of window sill!

Adjusting/measuring insect screen

Front-mounted external venetian blinds R6/R10



KD010052037

Fig. 122: Presetting of the insect screen

"X" = bottom edge of handle rail to bottom edge of guide rail:
 Standard setting „X“ = 10 mm if ordered without further specification.

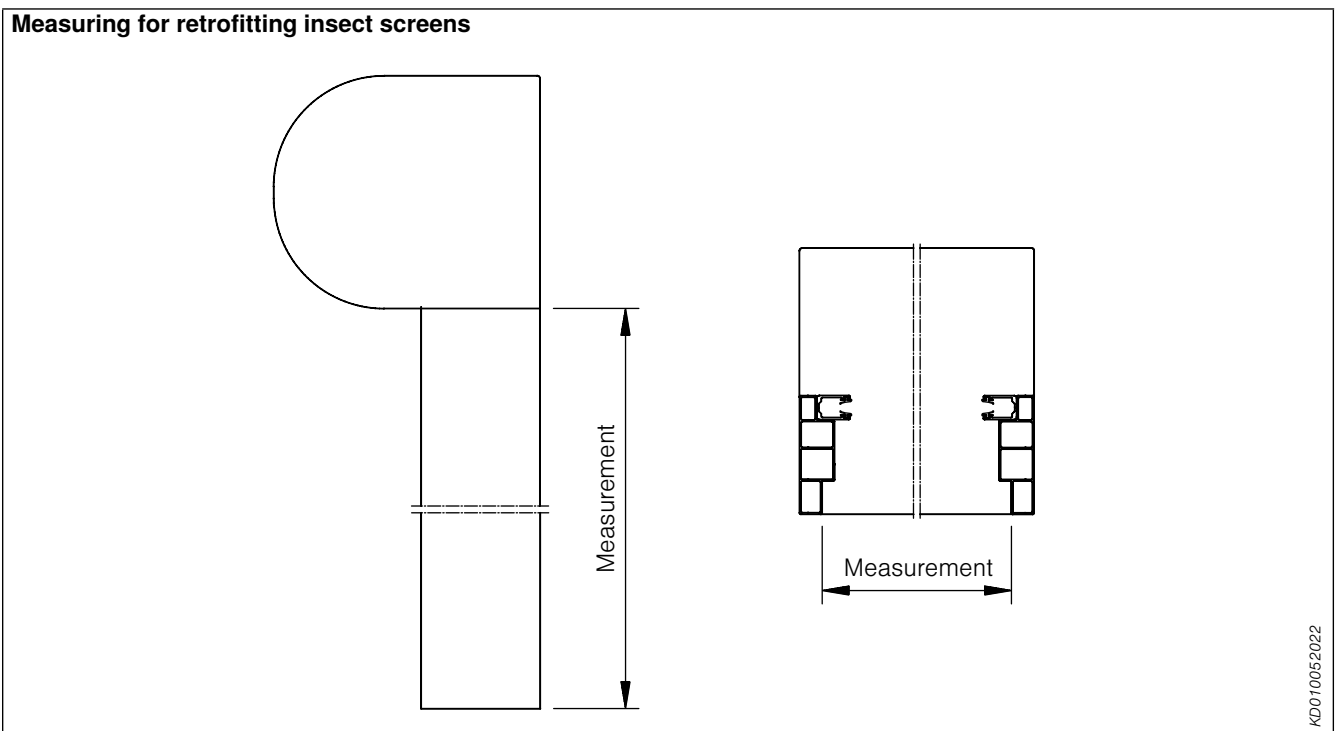

KD010052022

Fig. 123: Measuring for retrofitting insect screens

Please state dimensions according to drawing or state order number and item.

Insect screen swivel frame
Front-mounted external venetian blinds R10

Front-mounted external venetian blinds with swivel frame, one-wing

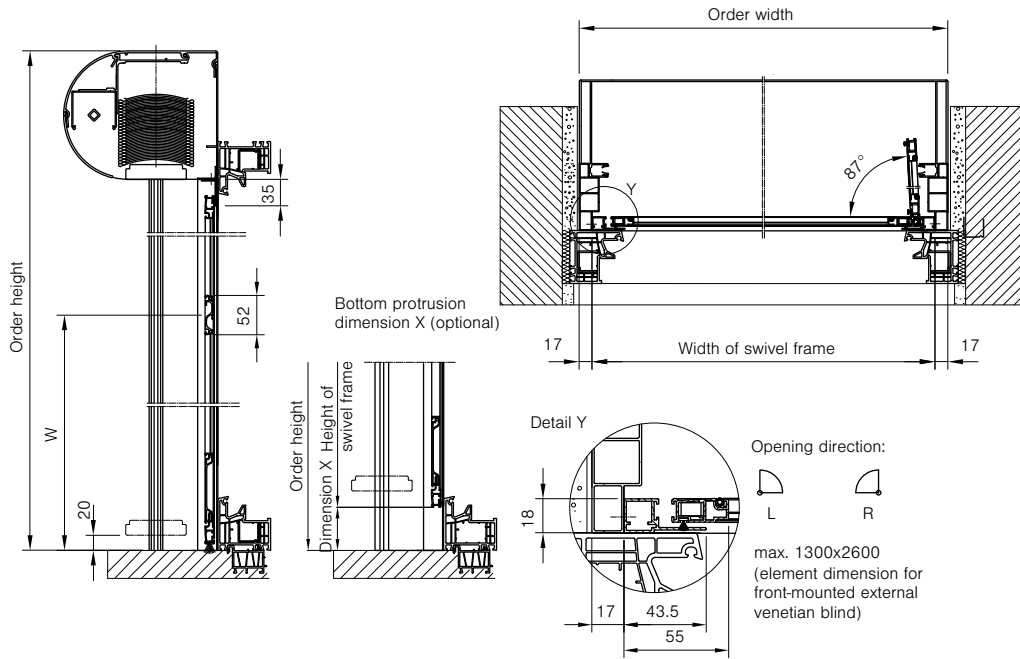

Kd010052133v1

Fig. 124: Front-mounted external venetian blinds with swivel frame, one-wing

Front-mounted external venetian blinds with swivel frame, two-wing

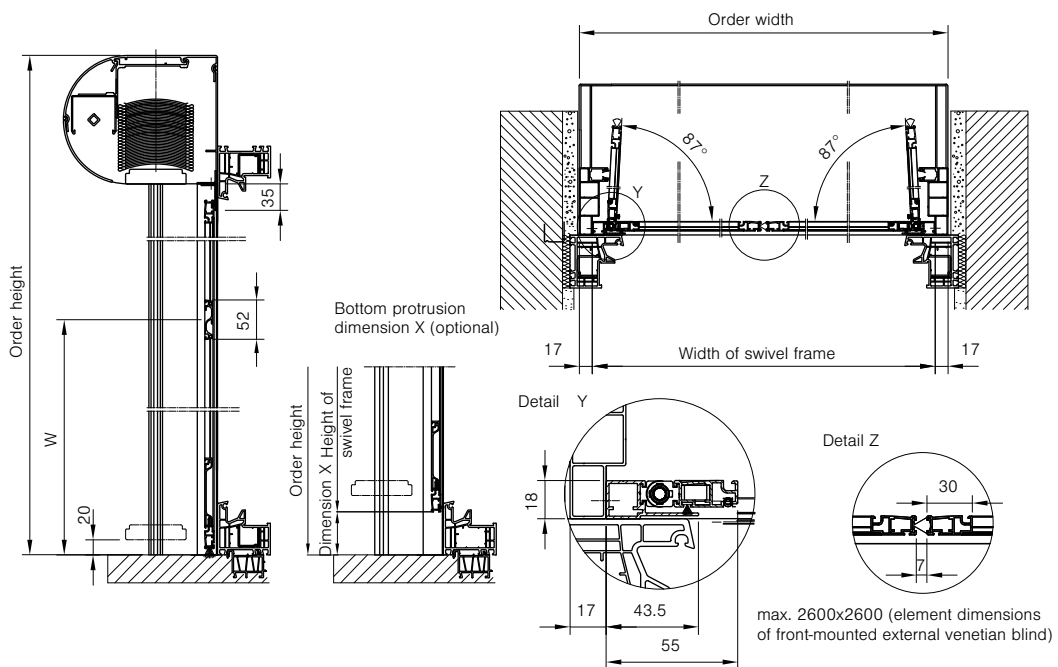

Kd010052143v1

Fig. 125: Front-mounted external venetian blinds with swivel frame, two-wing

Insect screen swivel frame

Front-mounted external venetian blinds R10

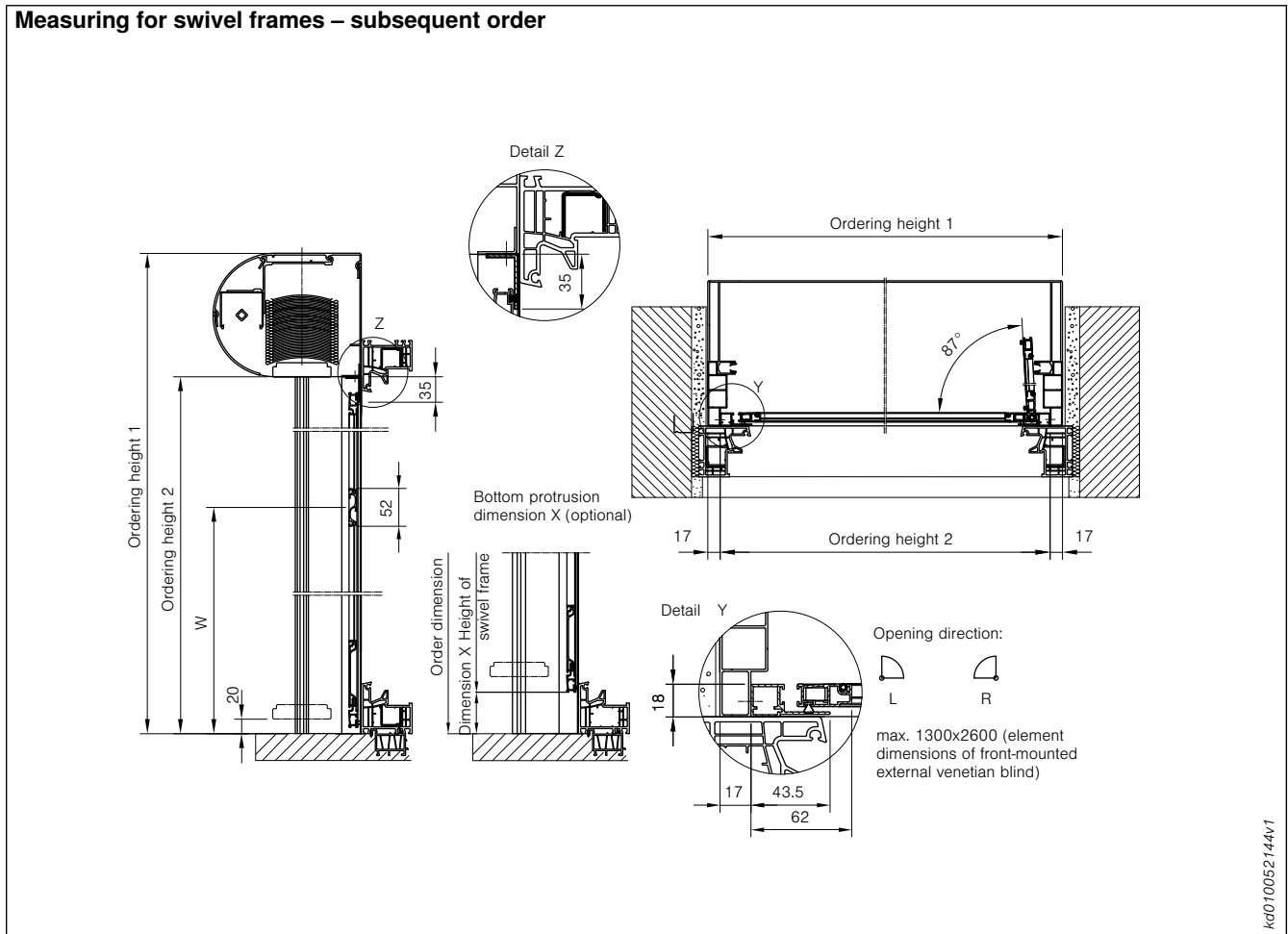

Fig. 126: Front-mounted external venetian blinds with swivel frame, two-wing

Construction limit values with insect screen swivel frame in mm

(element dimensions front-mounted external venetian blind R10)

R10	Width		Height ¹⁾	
	min.	max.	min.	max.
one-wing	500	1300	700	2700
two-wing	1000	2600	700	2700

¹⁾ From ordering heights over 1900 mm a kick plate and a bar are included in the standard delivery; if no dimension "W" is specified, the bar will be positioned centrally in the insect screen swivel frame.

For subsequent orders please state the box size.
Alternatively the insect screen swivel frame can be ordered subsequently using the WA and item number.

Order data for combinations

Front-mounted external venetian blinds R6/R10

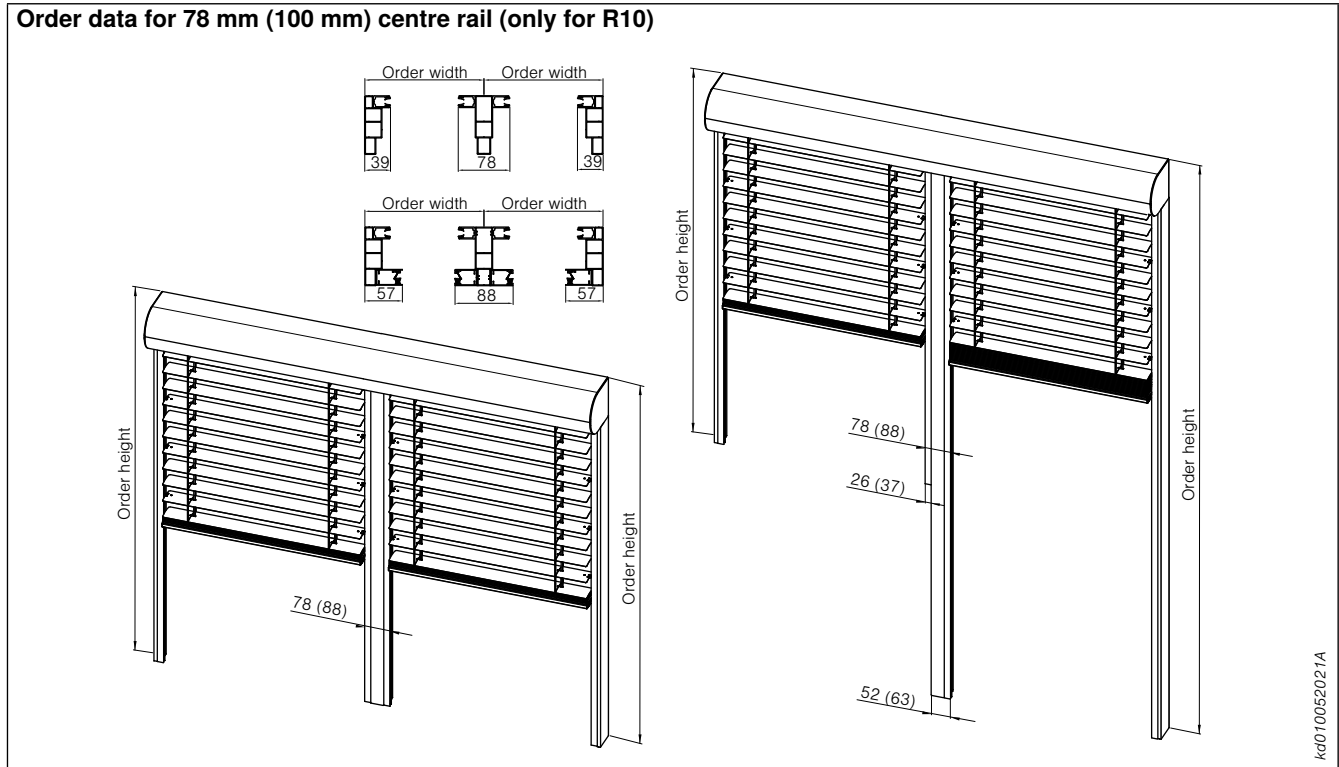

Fig. 127: Order data for 78 mm (100 mm) centre rail (only for R10)

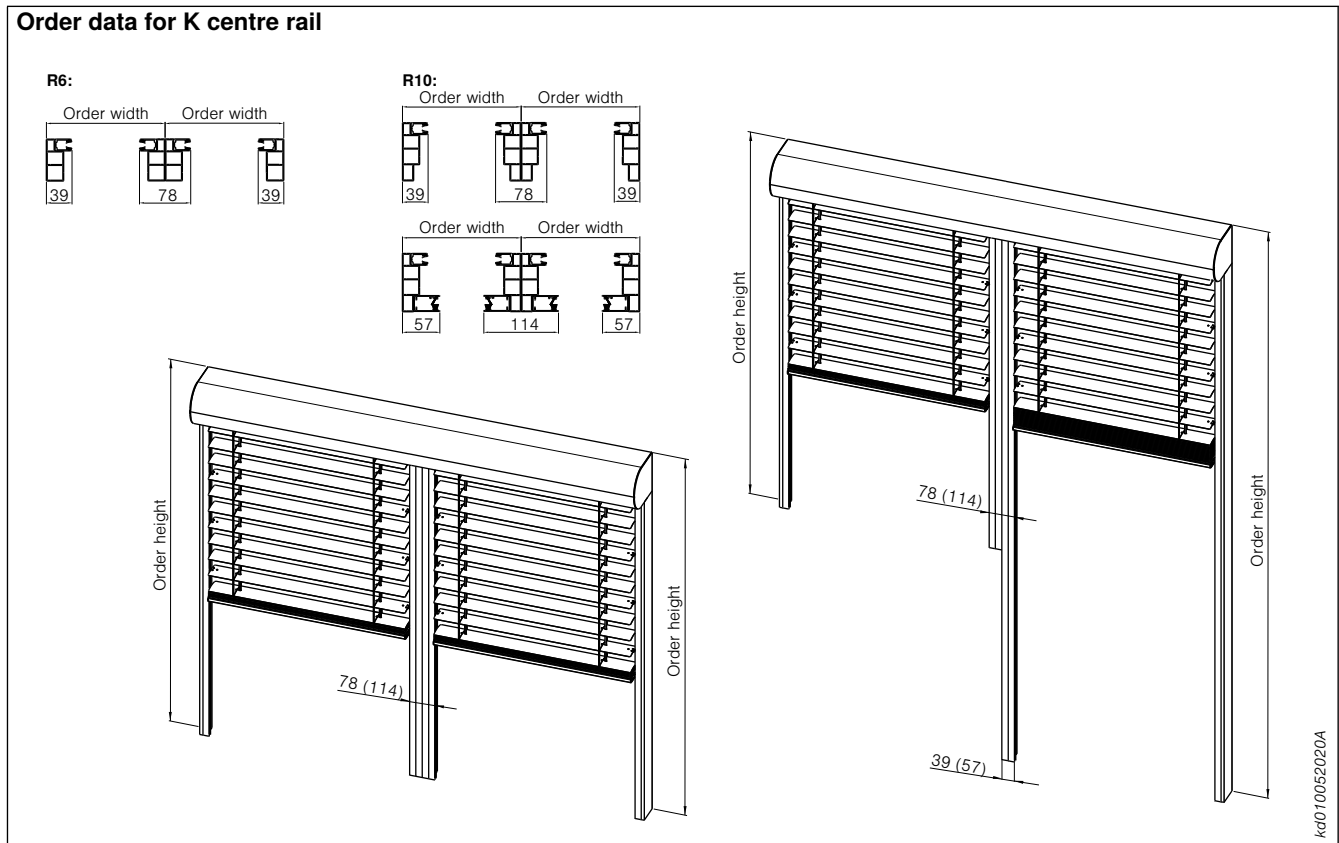

Fig. 128: Order data for K centre rail

Box extension

Front-mounted external venetian blinds R6/R10

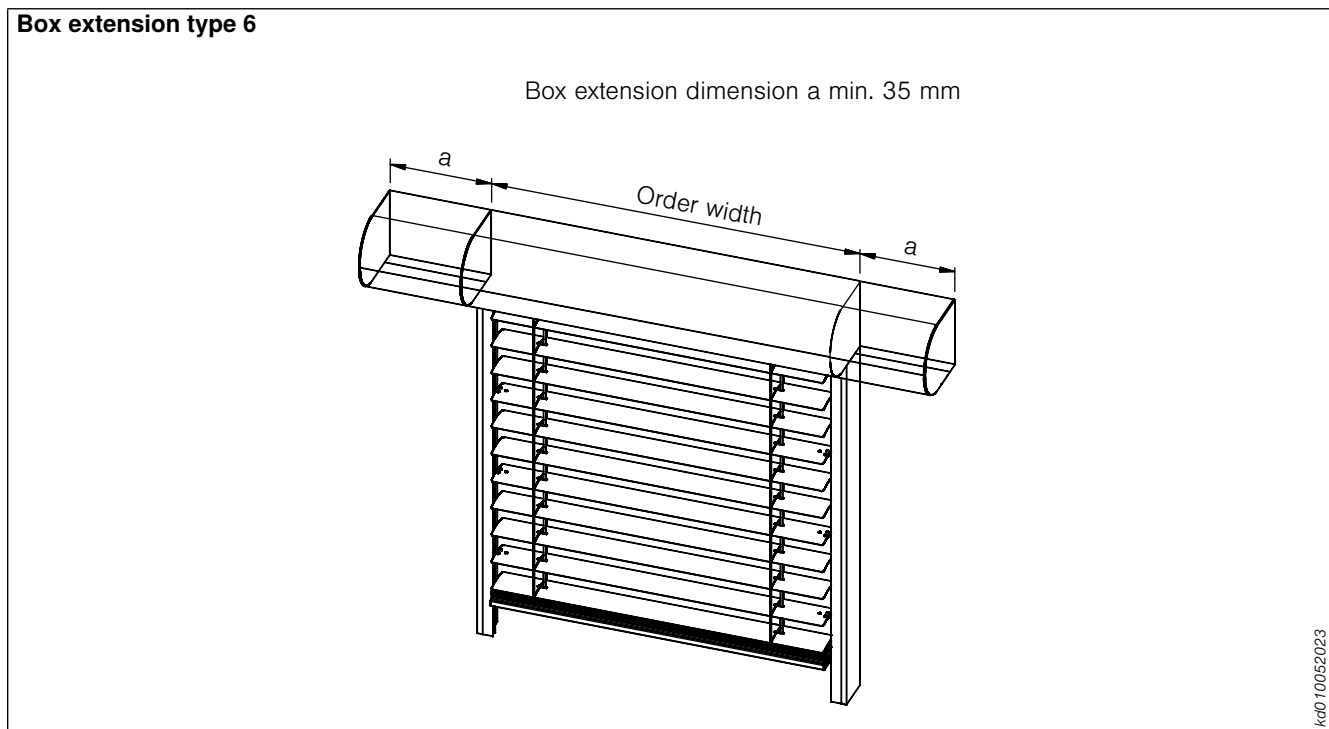

Fig. 129: Box extension type 6

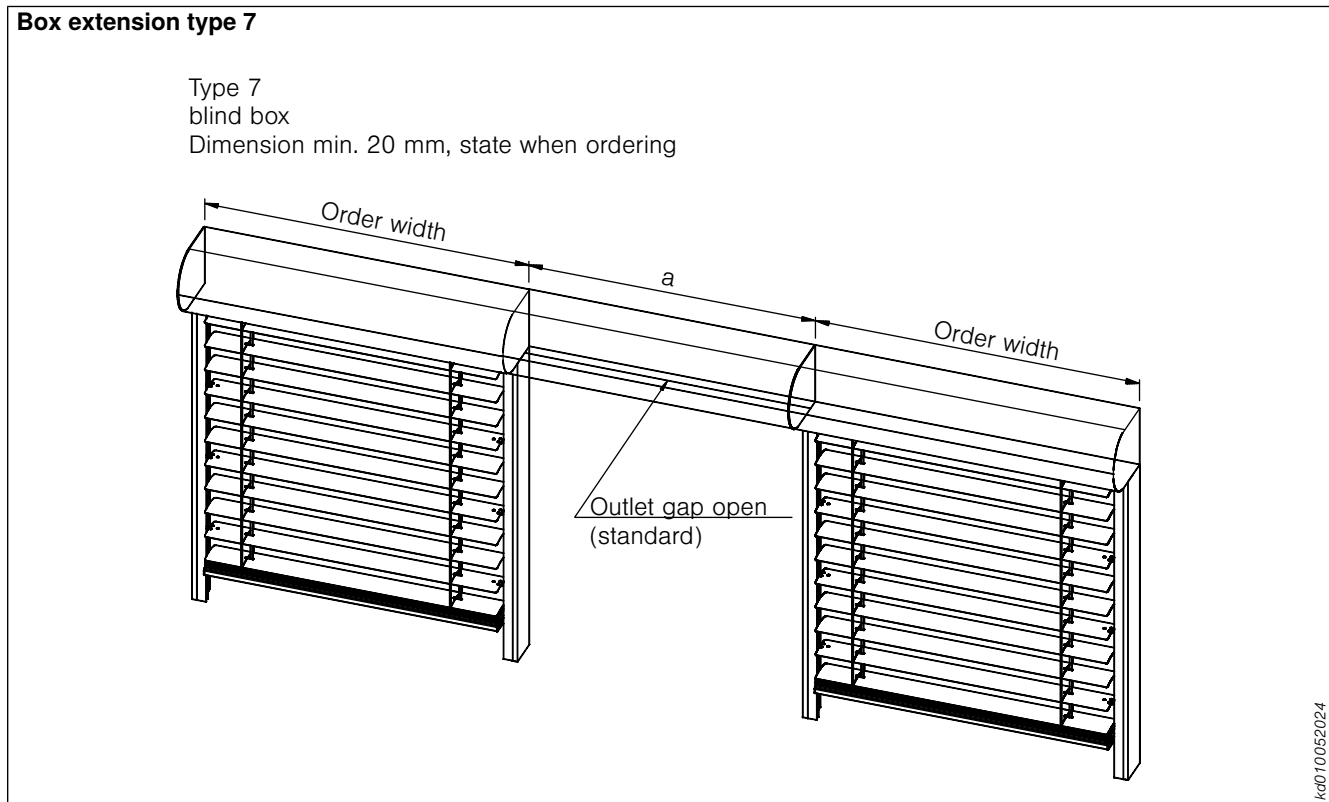

Fig. 130: Box extension type 7

Box extension – outlet gap closed
Front-mounted external venetian blinds R6/R10

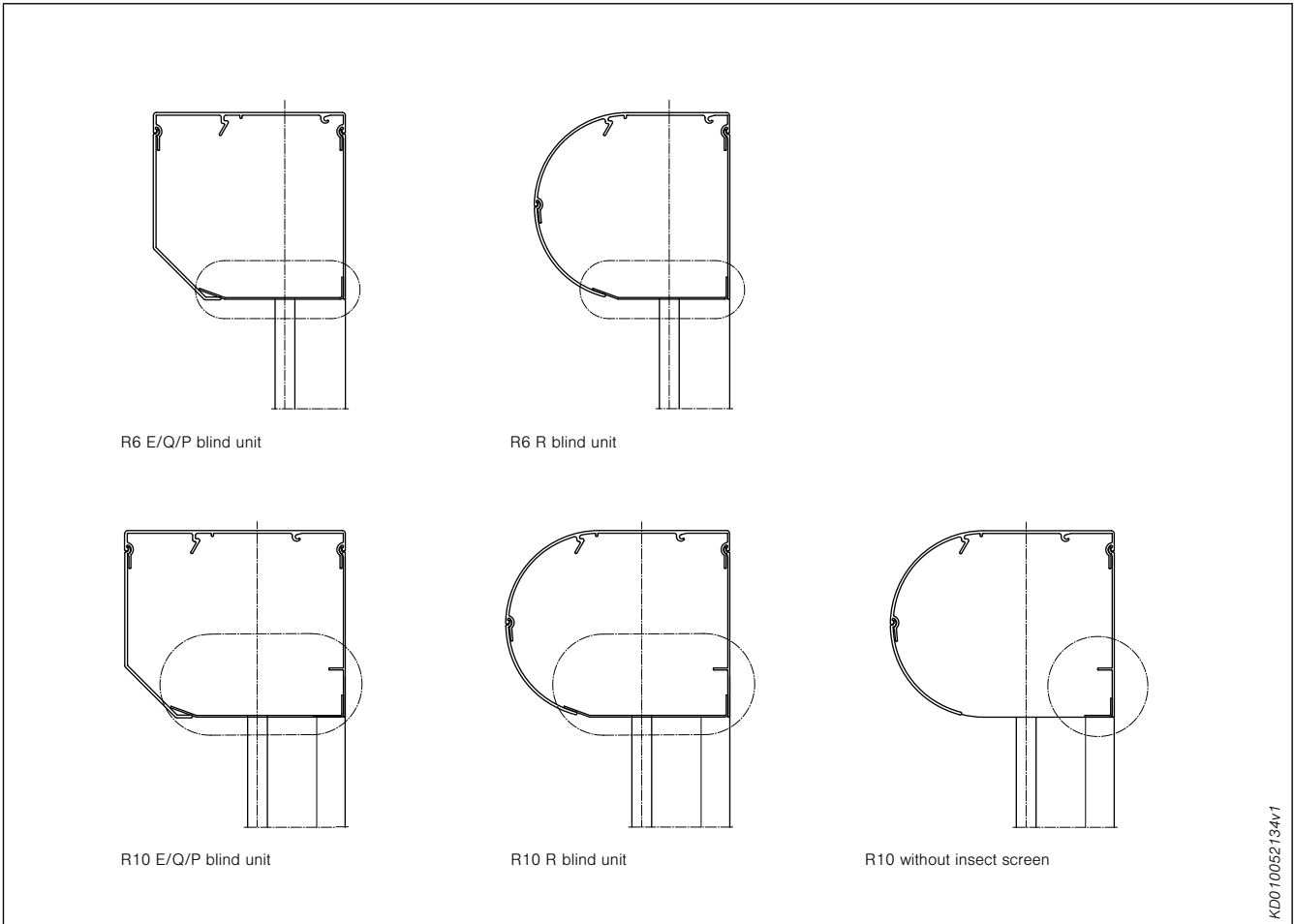

Fig. 131: Box extension – outlet gap closed (optional)

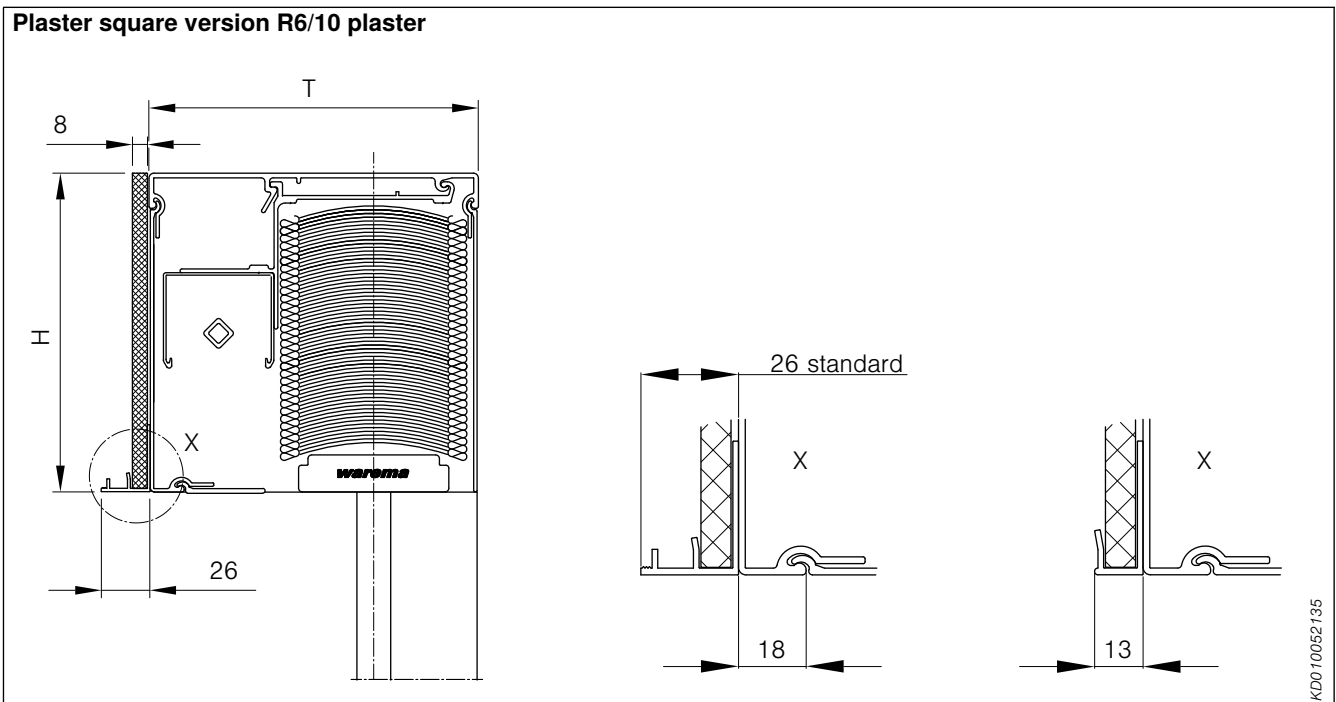

Fig. 132: Plaster square version R6/10 plaster (short plaster square subject to surcharge)

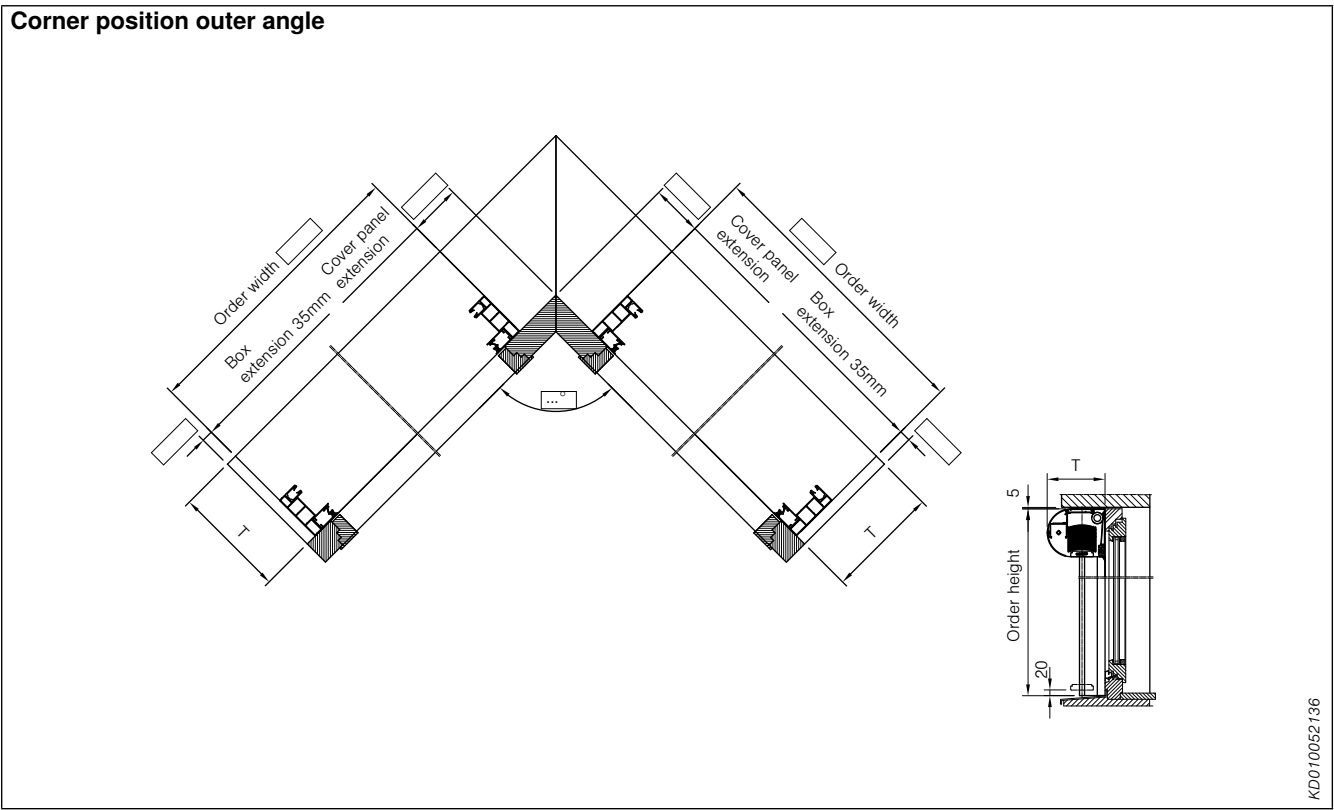

Fig. 133: Corner position outer angle

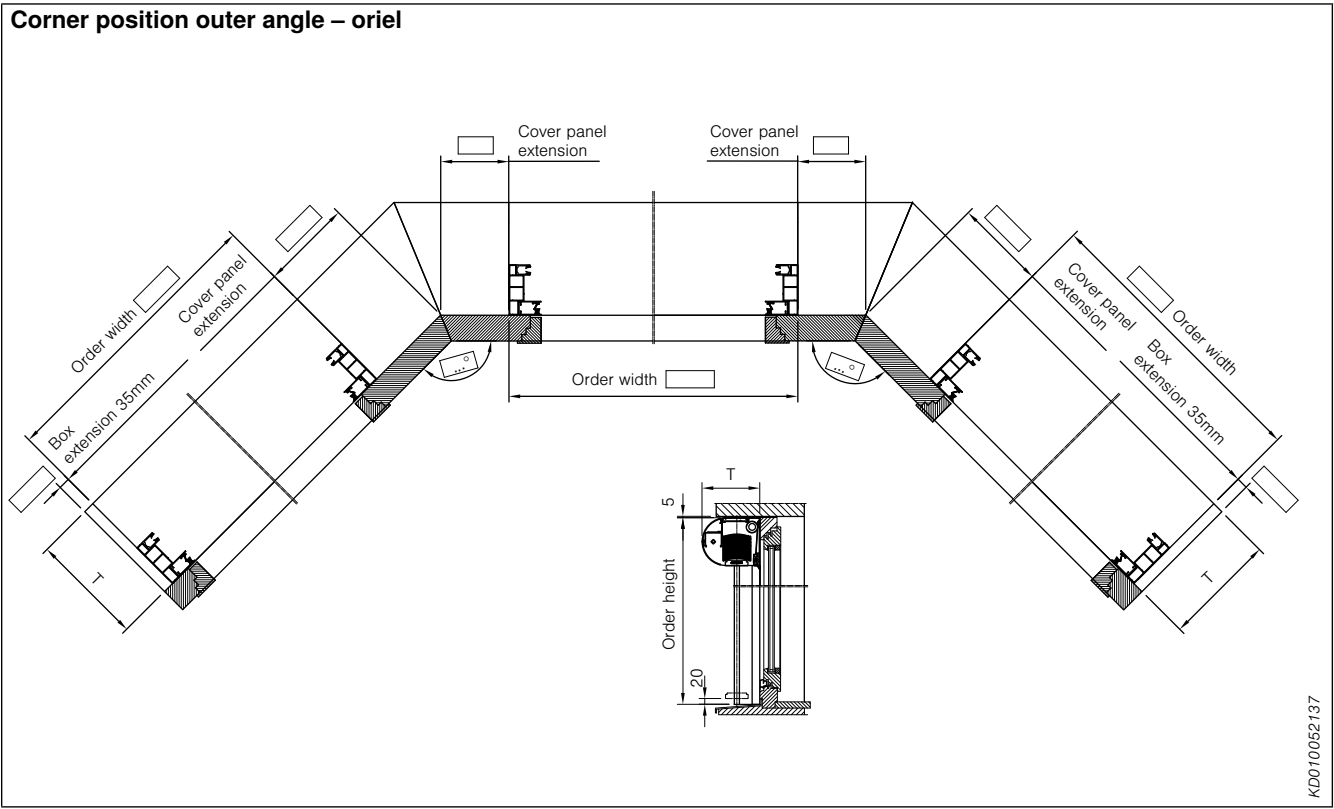

Fig. 134: Corner position outer angle – oriel

Box extension/corners

Front-mounted external venetian blinds R6/R10

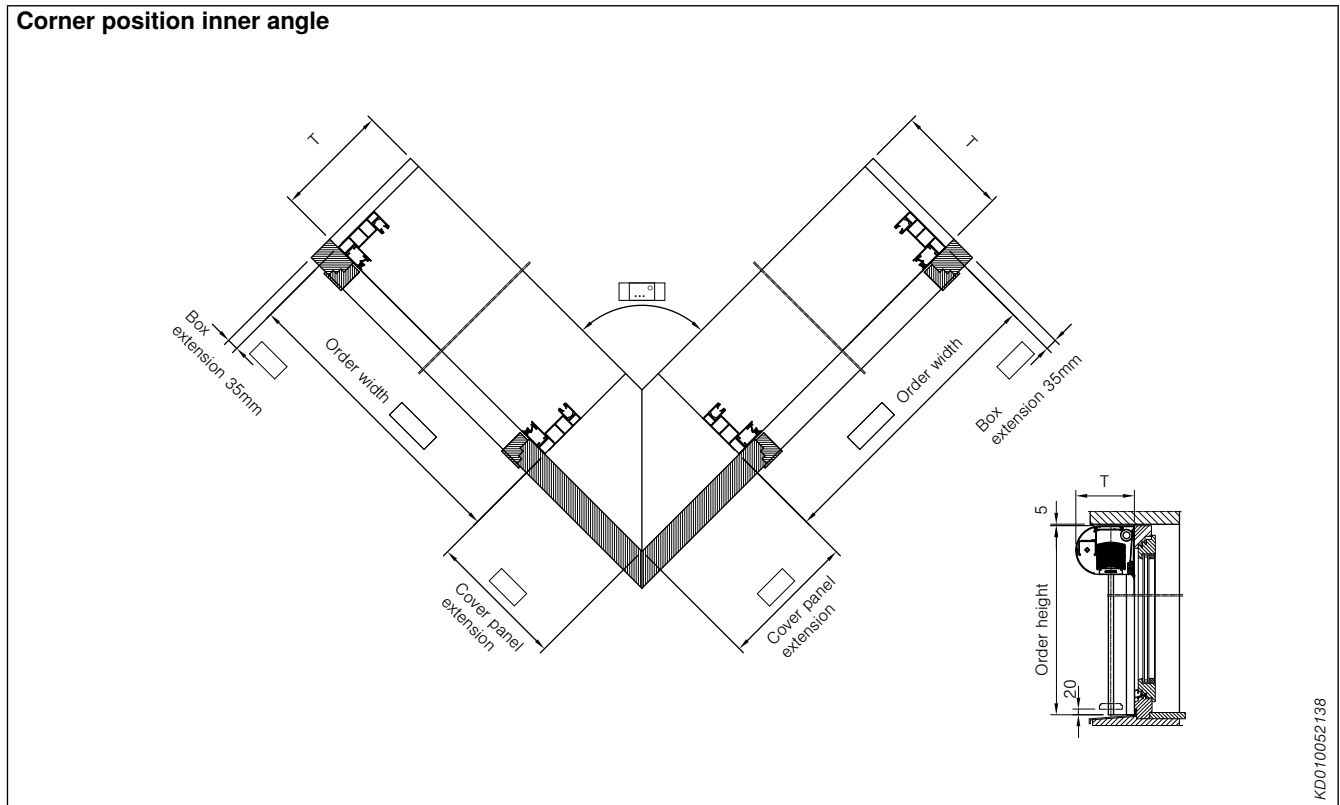

Fig. 135: Corner position inner angle

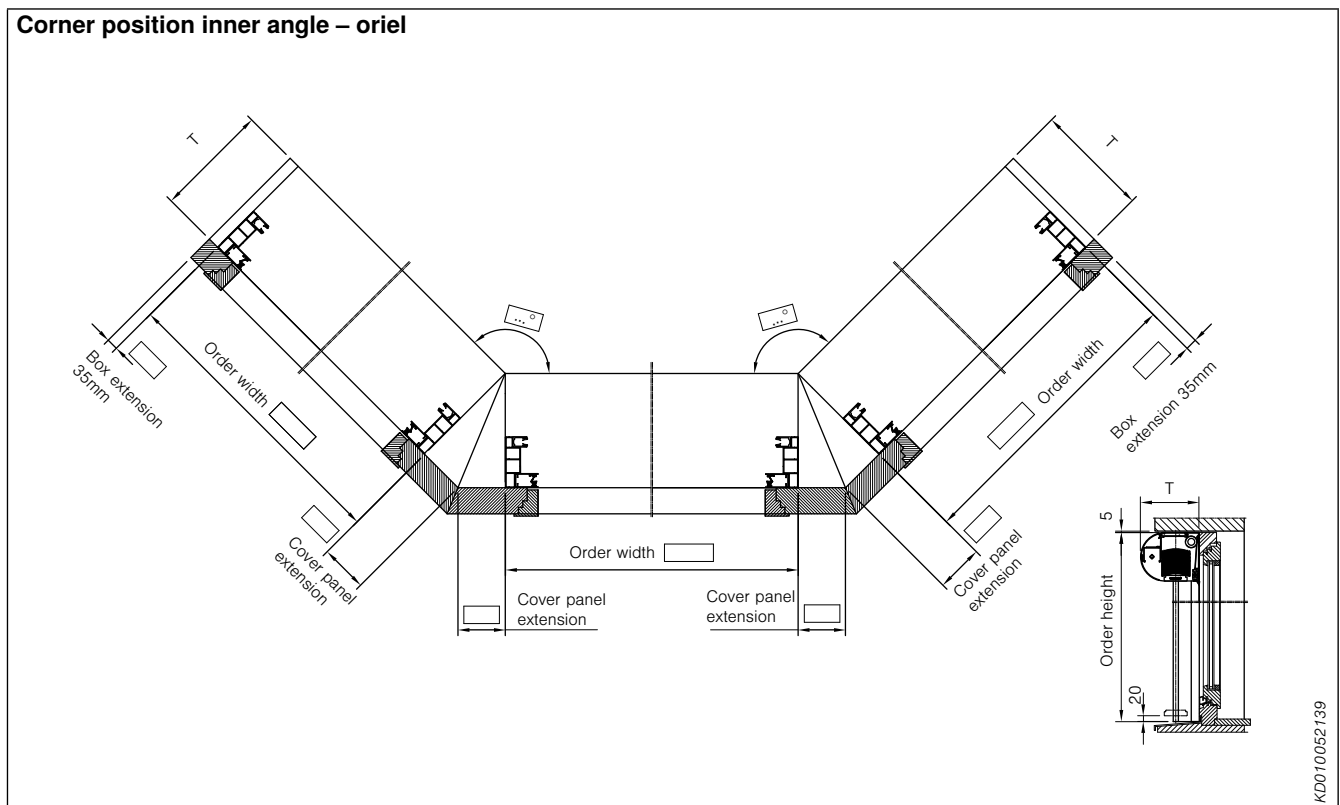

Fig. 136: Corner position inner angle – oriel

Additional box fastening

Front-mounted external venetian blinds

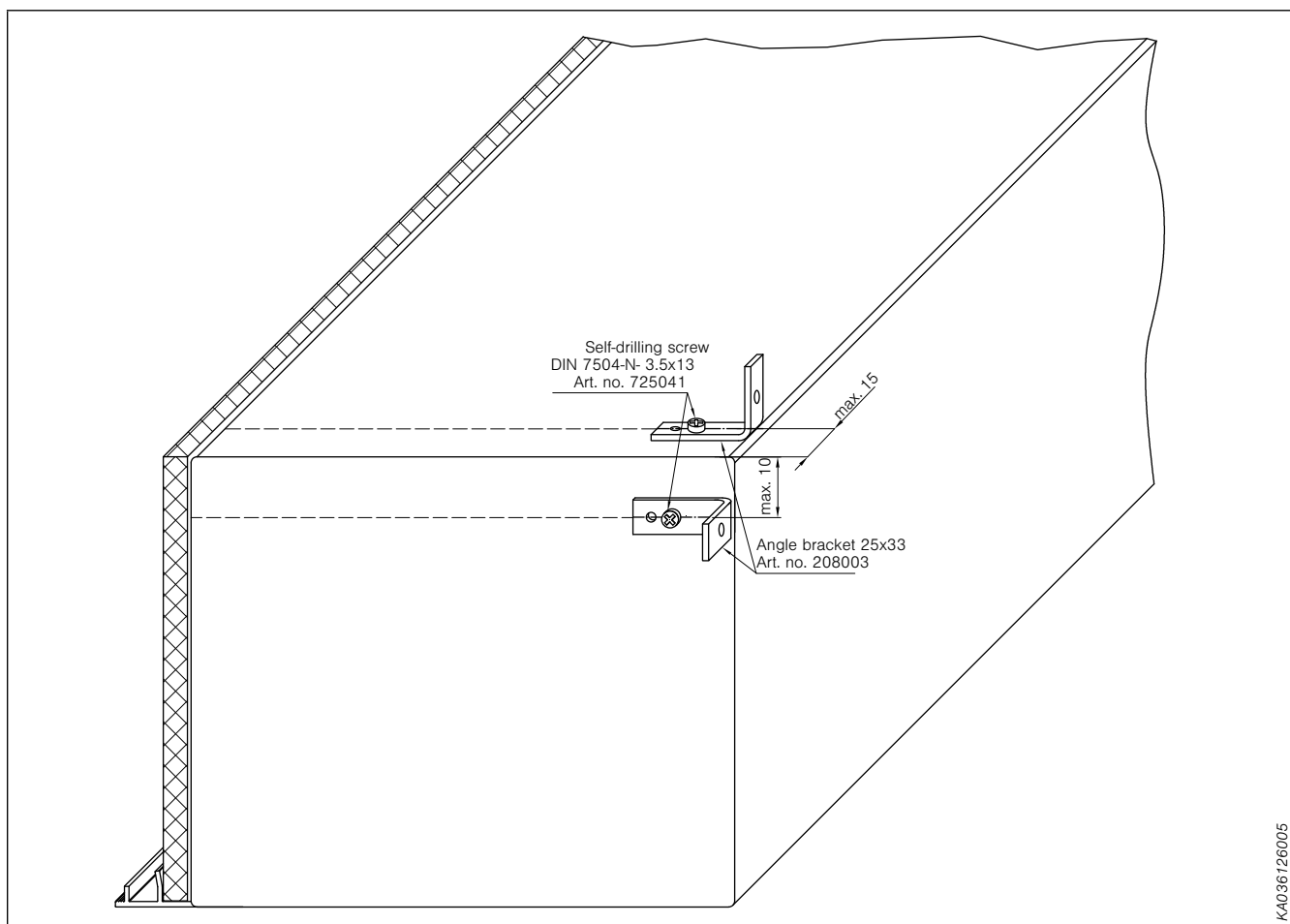

Fig. 137: Additional box fastening

From order widths over 1500 mm we recommend an additional box fixing for elements set in plaster. For models with plaster elements or for box shape Plaster these are always supplied without surcharge.

Scope of delivery

Angle bracket 25x33 mm, art. no. 208003.
Per bracket: 2 drilling screws DIN 7504-3, 5x13,
art. no. 725041

Notes:

- The fixing brackets can be positioned alternatively at the top or at the side
- Do not use any screws longer than the ones supplied
- The maximum clearances (10 and 15 mm, resp.) have to be observed
- The angle bracket can also be turned and moved along the lines shown

Drilled hole for on-site installation 4.2 mm

Tilting behaviour details

Front-mounted external venetian blinds R6/R10

80 mm beaded slats

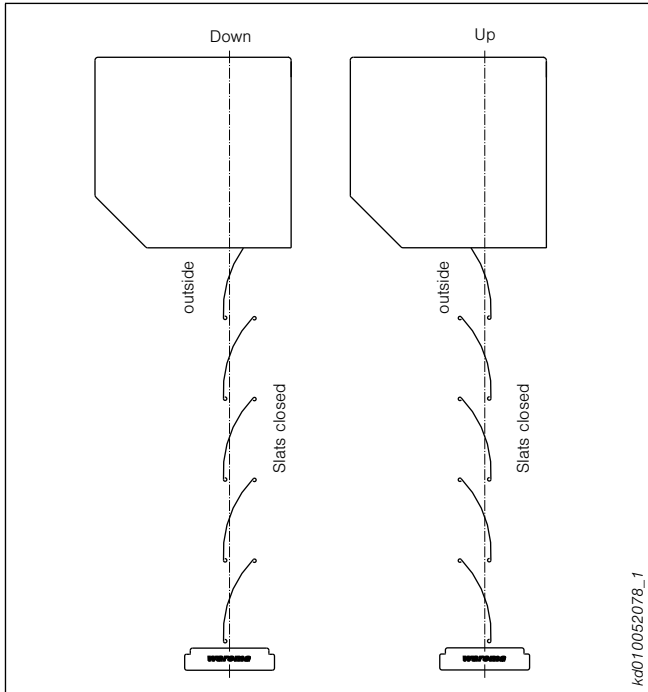

73 mm dim-out slats and external venetian blinds with vivamatic® or slowturn

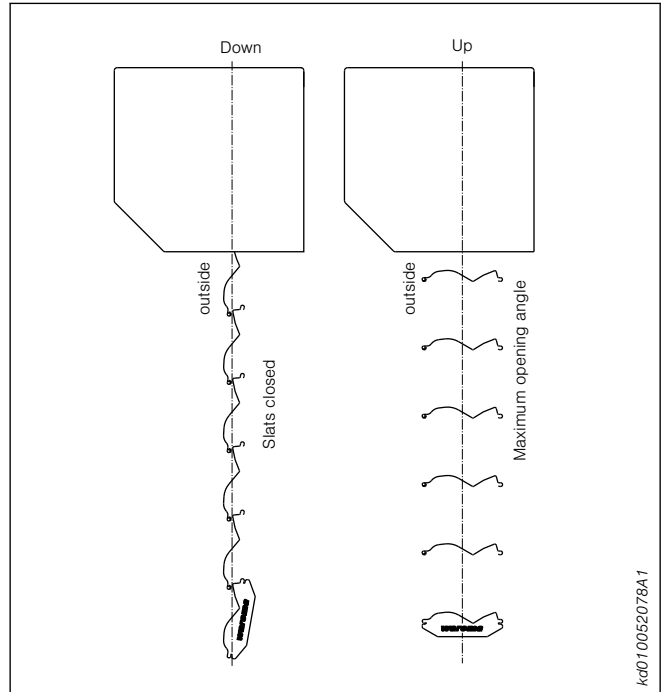

80 mm flat slats

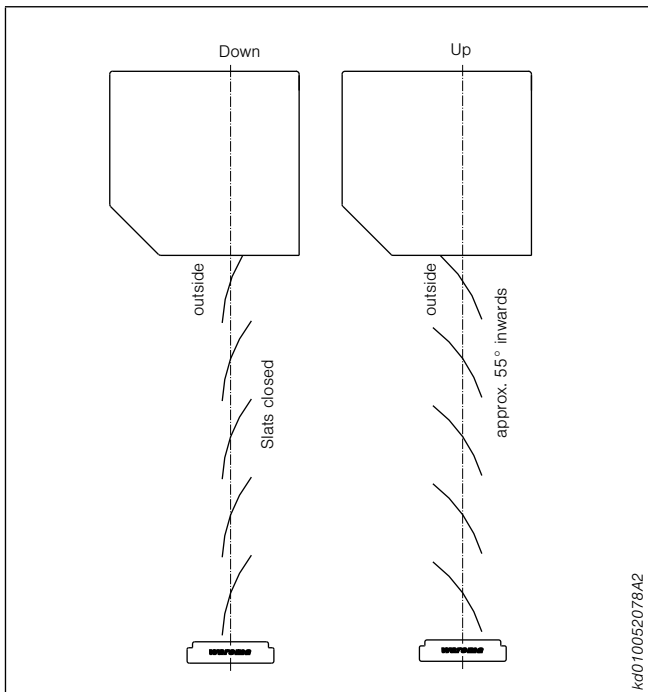

From a fabric width of more than 2400 mm we recommend additional wind protection in the form of a tension cable for models with flat slats – type 80 AF A6.

NEW

WAREMA vivamatic® – daylight management for external venetian blinds

External venetian blinds with vivamatic® technology are the blinds of the future, both with regard to energy efficiency and to economy. In contrast to conventional external venetian blinds they are lowered with the slats already perfectly adjusted to the sun azimuth circle angle, achieving ideal illumination of the room and heat protection during lowering. This results in optimised incidence of energy from the first moment while at the same time the user is not disturbed unnecessarily or even forced to manually readjust the slats. External venetian blinds with vivamatic® are generally controlled by the intelligent WAREMA climatronic® central control system which is ideally coordinated with this system. It uses current time of day, date, positioning of the building and insolation intensity to determine the best possible slat angle and positions the external venetian blind slats perfectly.

The reduced slat tilting time slowturn is a standard feature for external venetian blinds with vivamatic®!

Highlights:

- Maximum daylight utilisation without darkening the room already during lowering (user remains undisturbed)
- Reduced slat tilting speed for more precise positioning (slowturn)
- Variable slat positioning at the best possible angle through intelligent control with WAREMA climatronic® already before lowering the external venetian blinds
- Continuous automated readjustment of the slat angle during the course of the day
- Reduced use of artificial light, artificial light not required for the short period of lowering the external venetian blinds
- Reduced cooling loads for air-conditioned rooms
- Models generally with standard external venetian blinds motors 230 V AC

More information, visualisations as well as a demo tool can be found on www.vivamatic.com.



Table of available types with vivamatic® (VM)

vivamatic®	Maximum dimensions
E 80 A6 VM	see resp. ext. venetian blind basic type
E 80 A6 VM offset	
E 80 AF A6 VM	
E 73 A6 VM	

Notes:

- Max. 3 units can be coupled mechanically
- Slat tilting of external venetian blinds from closed towards the outside to horizontal (page158)
- Controlled via WAREMA climatronic® with vivamatic® actuator

Operating principle vivamatic®

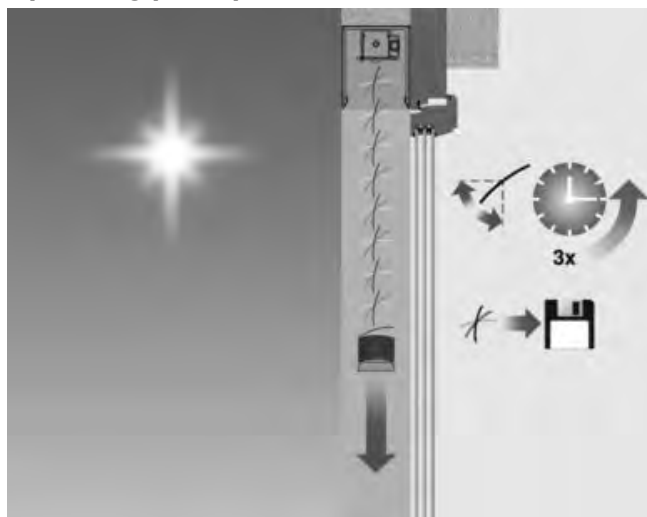

Fig. 138: Operating principle of external venetian blinds with vivamatic®

Mounting example Venetian blinds facade system with vivamatic®

NEW

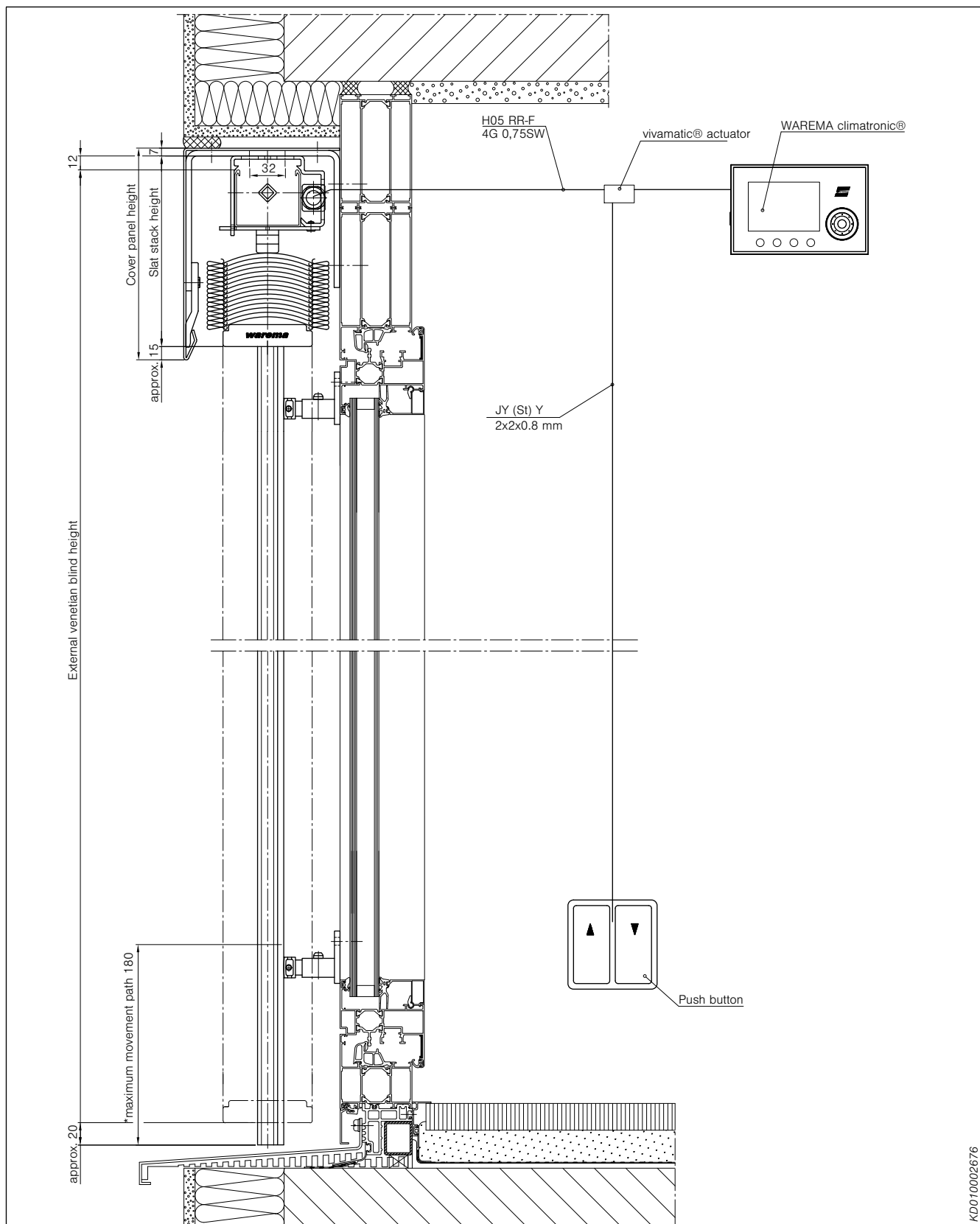

Fig. 139: Mounting example for venetian blinds facade system with vivamatic®

*maximum required movement path depending on external venetian blind type and slat position. This allows readjusting or closing the slats when the external venetian blind is fully lowered. This function is automated and controlled by the higher level control. User intervention is not required.

Description/type overview

slowturn

NEW

slowturn – reduced slat tilting speed for external venetian blinds

External venetian blinds with the equipment option slowturn feature a reduced slat tilting speed which allows more exact positioning of slats compared to standard external venetian blinds, with higher-level control system as well as with manual operation. The available tilting time is three times as long as for standard external venetian blinds.

Highlights:

- More precise slat positioning through reduced slat tilting time
- Models generally with standard external venetian blinds motors 230 V AC
- We recommend control via an intelligent WAREMA sun shading control system for best possible energy efficiency.

Notes:

- Control should be effected via a sun shading control system with adjustable slat tilting times (e.g. WAREMA climatronic®).
- When using WAREMA mobile system (WMS), commissioning has to be carried out via the WMS Studio software. Operation with WAREMA radio system EWFS is not possible, for control systems with preset time logic function please consult WAREMA before execution.

Table of available types with slowturn

slowturn	Maximum dimensions
E 80 A6 ST ¹⁾	see resp. ext. venetian blind basic type
E 80 A6 ST offset ¹⁾	
E 80 AF A6 ST	
E 73 A6 ST	

¹⁾ Models with 80 mm beaded slats also with special tilting behaviour, slats closed to the outside to slats closed approx. 55° to the inside.

Notes:

- Slat tilting of external venetian blinds from closed towards the outside to horizontal (page158)
- Max. 3 units can be coupled mechanically

Operating principle of slowturn

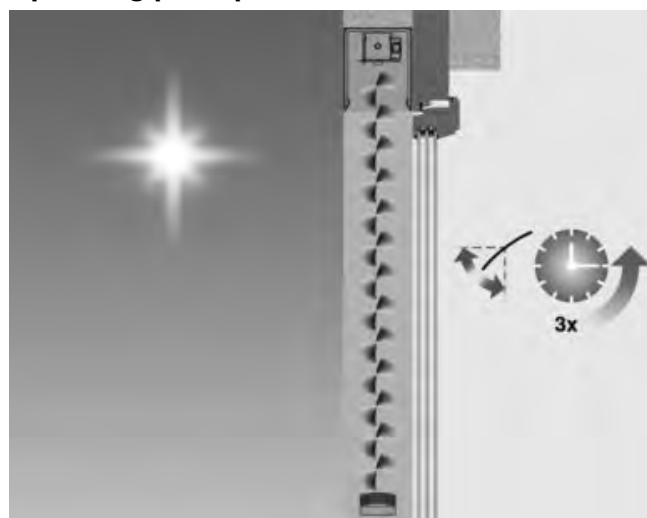
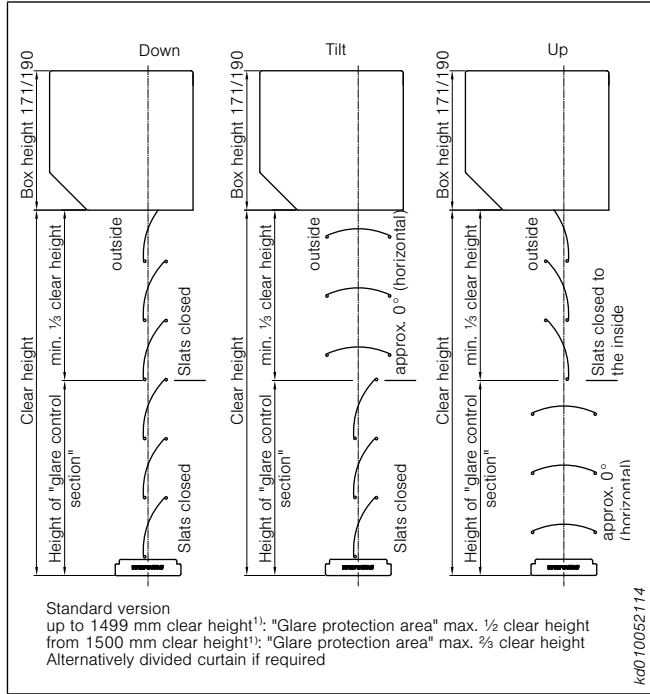

Fig. 140: Operating principle of external venetian blinds with slowturn

Tilting behaviour details

Front-mounted external venetian blinds R6/R10 with daylight transport element

Tilting principle for tilting system 80 mm beaded slats



Tilting principle for tilting system 80 mm flat slats

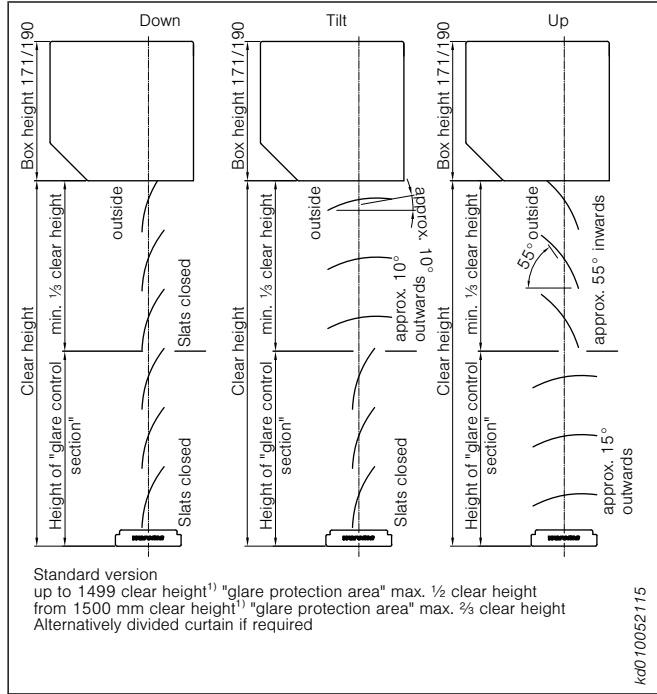

Tilting principle for tilting system 73 mm dim-out slats

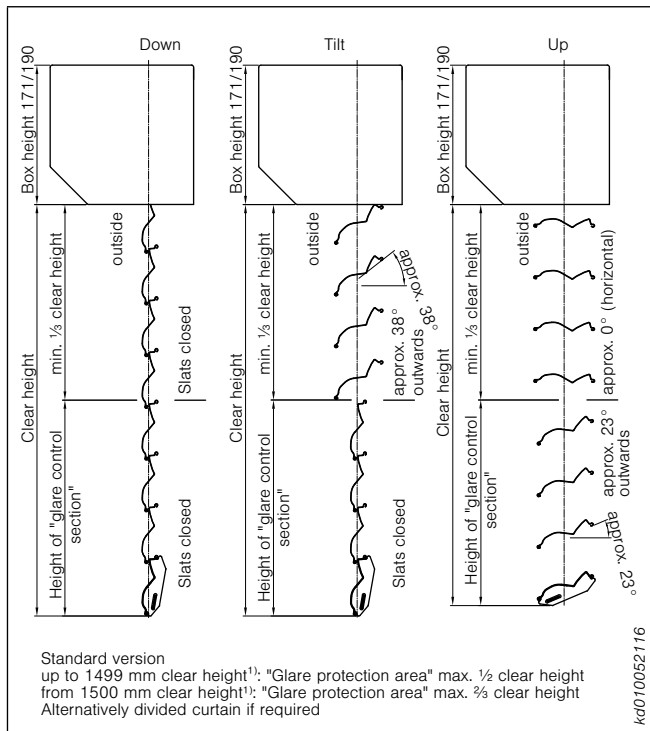

Maximum order height for models with daylight transport element: 3000 mm.

¹⁾ Clear height = order height front-mounted external venetian blind – box height

Front-mounted external venetian blinds R6/R10

80 mm flat slats

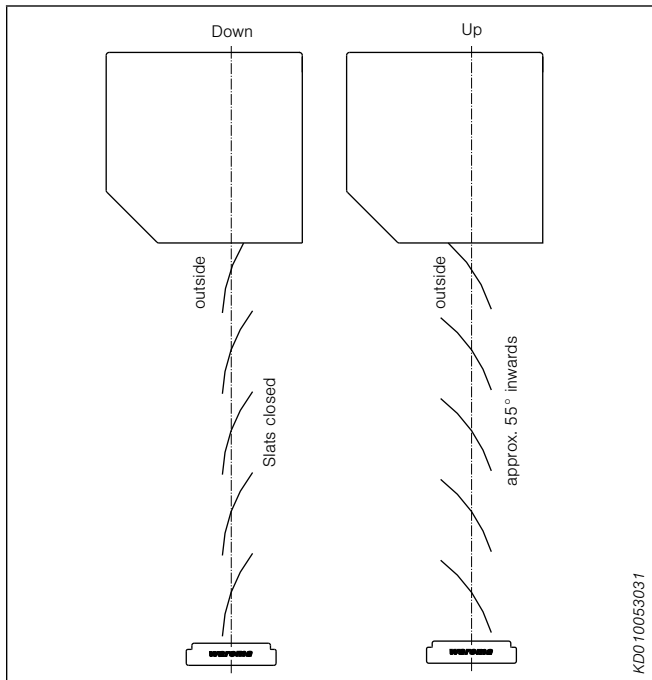

KD010053031

Model with flat slats

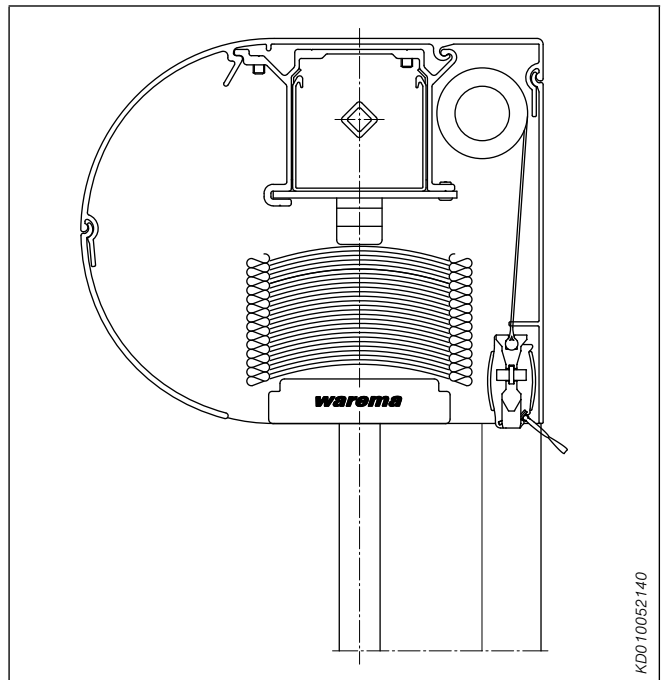

KD010052140

Fig. 141: Model with flat slats

Tension cable bracket type S01 for 80 mm flat slats

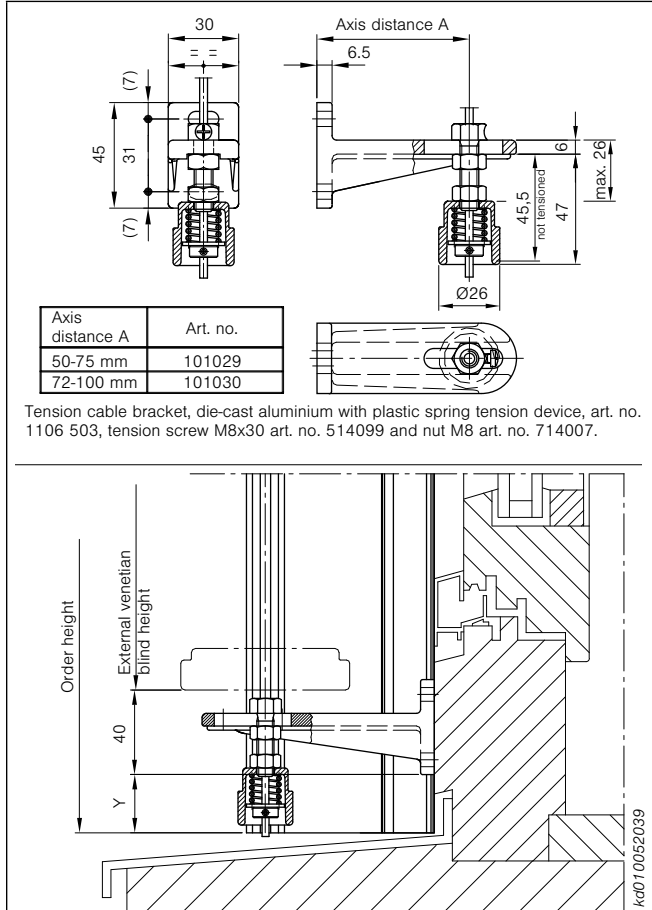

kd010052039

For models with flat slats type 80 AF A6 the unit is also produced with the top rail above the slats, depending on curtain height, box size and equipment. For models with crank drive only this model is used.

For models with flat slats type 80 AF A6, a tensioning cable must be used in the centre of the curtain for wind protection from an ordered width of 2400 mm.

Specify dimension "Y" when ordering.

Operation details

Front-mounted external venetian blinds R6/R10

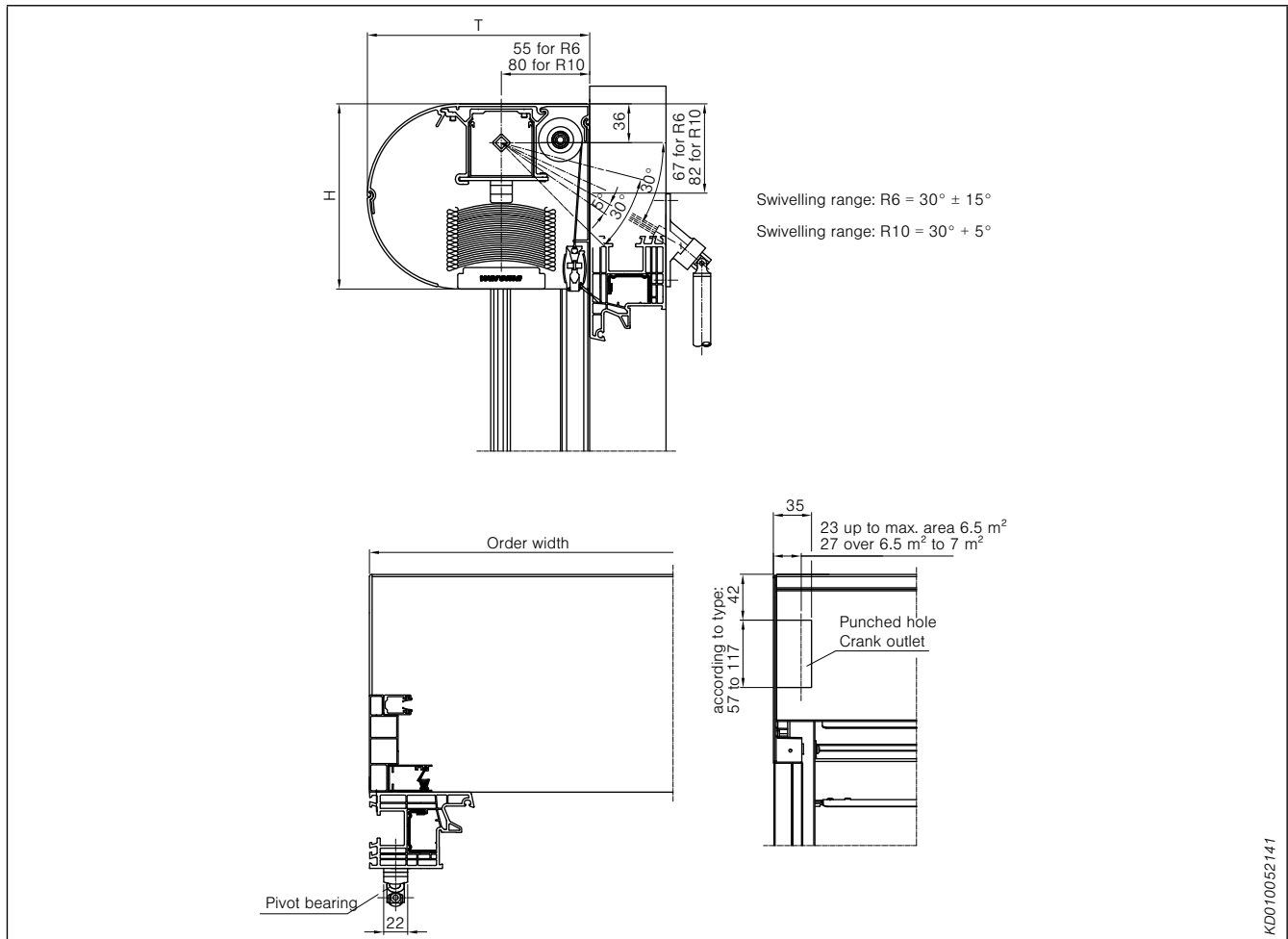

Fig. 142:

Notes:

- Max. curtain area for crank drive 7 m^2
- Max. 3 units can be coupled, only opposite side to operation side
- Gear outlet according to drawing
- Steel pivot bearing, nickel plated, crank C0 anodised
- External gear or gear in box extension not possible
- Only available for type 80 AF A6

Description

Concealed, maintenance-free AC motor with flanged planetary gear.

The upper and lower limit position can be set by means of the adjustment buttons.

A thermal protection which switches off automatically after approx. 4 minutes of overload is integrated in the motor. After reconnection, the chosen operation is then brought to its end. Each drive is equipped with a miniature plug connector via a flexible line. The motor must be covered (degree of protection IP54: „Protection against water spray/water jets from all directions).

Structure of the AC drive

Motor

Automatic asynchronous short-circuit motor.

Bearing

Ball bearing

Brake

Electro-mechanical brake.

Limit switch

Differential cam end switch.

Lubrication

Special grease provides sufficient lubrication throughout the overall product life.

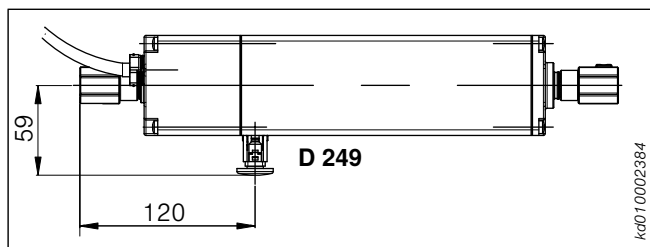

Fig. 143: Measuring instructions for external venetian blind middle motor type D 249

Technical data for standard motors*

Motor type		D 249	D 349	D 839
Torque	Nm	6	2x 5	2x 9.5
Power consumption	W	94	140	218
Current	A	0.41	0.6	0.97
Speed	rpm	26	26	26
Voltage	V	230	230	230
Frequency	Hz	50	50	50
Operating mode	KBmin	4	4	4
Protection rating	IP	54	54	54
Dowel-in connector		STAS 3	STAS 3	STAS 3
VDE 0700		yes	yes	yes
CE mark approval		yes	yes	yes
VDE EMC		yes	yes	yes
Temperature range	°C	-20 to +80	-20 to +80	-20 to +80

*Motors for other mains voltages are available on request!

Note:

The control of the motors for operation with the WAREMA radio systems WMS and EWFS is effected with a radio plug receiver! If ordered together with the front-mounted external venetian blinds, this receiver will be supplied pre-installed in the box.

Possible cable outlets

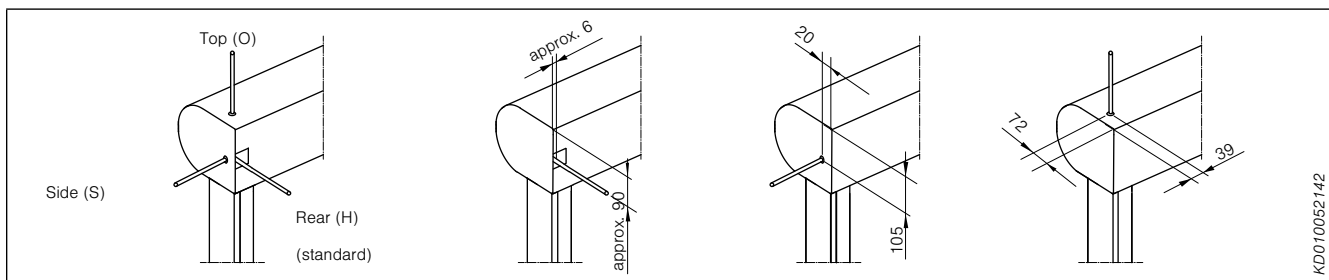

Fig. 144: Cable exit

Cable exit at the rear = standard. In case of a cable exit lateral or on top, the motor cable is sealed by means of plug-

in grommets. Cable excess 1000 mm, 5000 mm or 10000 mm also possible.

Operation details

Front-mounted external venetian blinds – motor operation

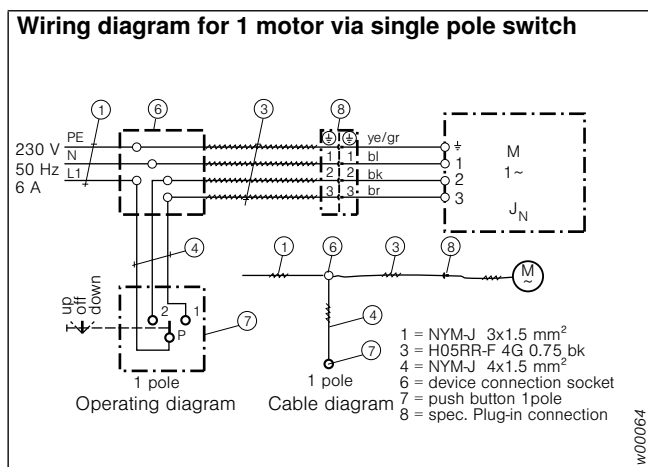
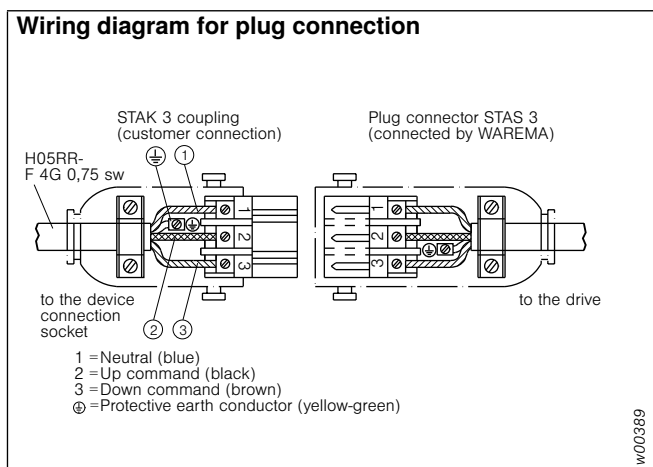

Fig. 145: Switching instructions

Important!

Follow the wiring diagram carefully to avoid damage to the motor.

Several motors must not be controlled without cutoff relay or suitable motor control unit via an operating switch.

We cannot accept liability for damage caused by improper installation.

The fixed electrical installation has to be carried out by a certified electrician in accordance with VDE 0100 or the legal requirements and standards of the respective country.

According to VDE 0022, the operator and constructor are solely responsible for compliance with power supply company and VDE regulations.

Positioning

Front-mounted external venetian blinds R6/R10 Solar

When planning installations, please make sure that no obstacles as described below are present at the installation site.

As a rule of thumb, you must ensure that the sky is directly visible from the angle of vision of the solar panel.

If the shutters are mounted in a northern, north-western or north-eastern direction, the solar panel should have an unhindered view of the sky in all directions.

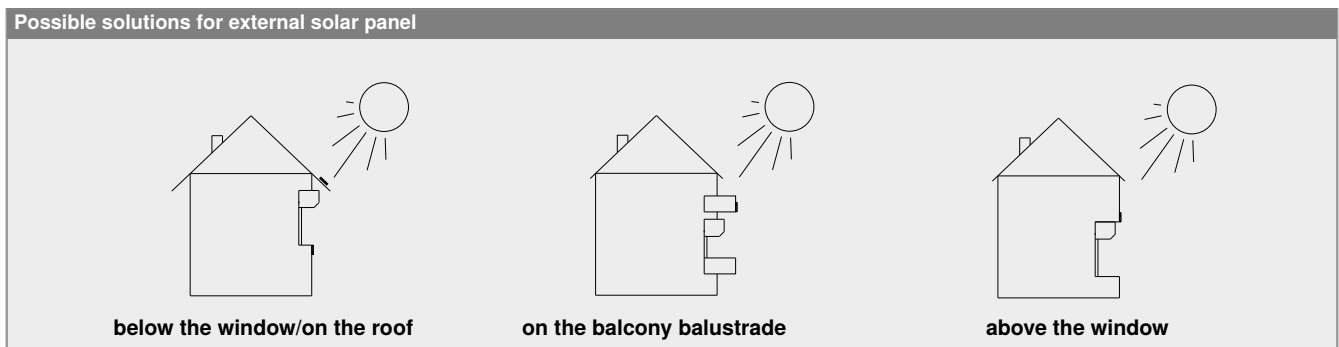
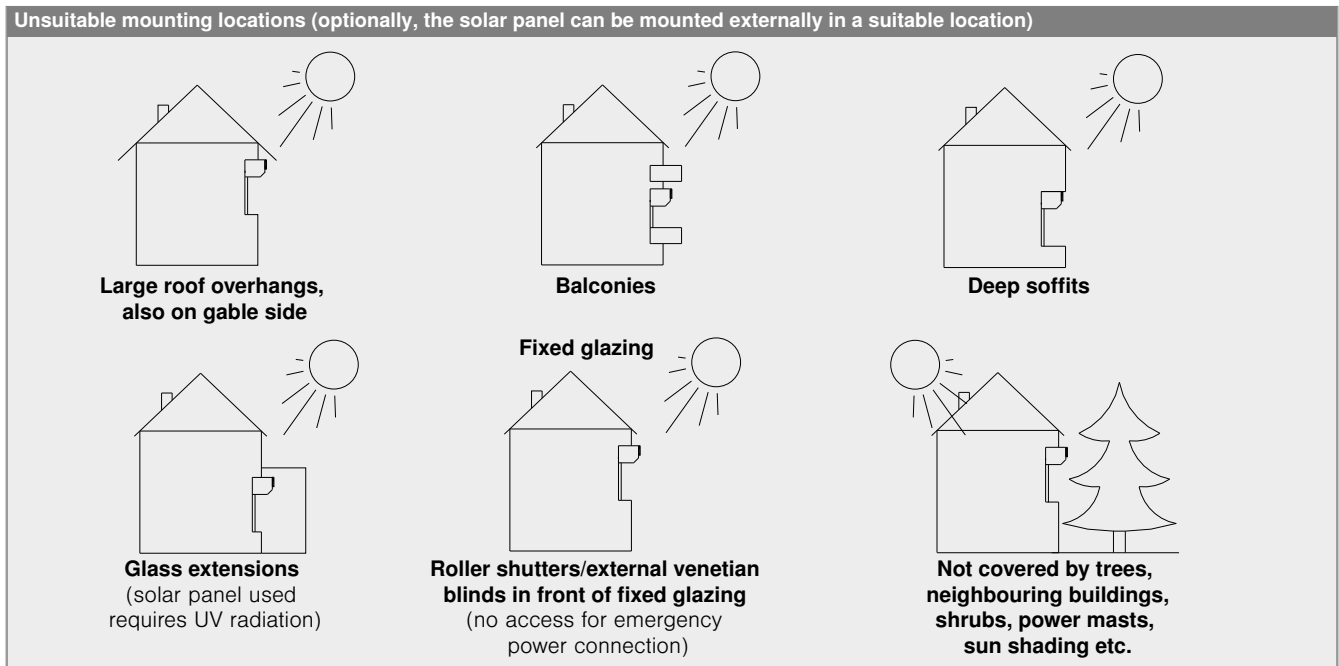
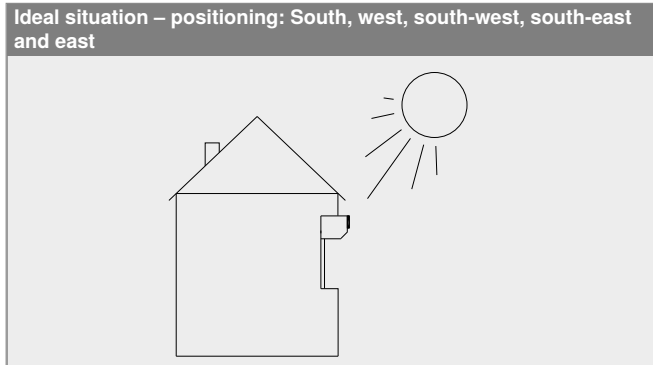

Operation details

Front-mounted external venetian blinds R6/R10 Solar

Solar drive¹⁾ (optional)

Concealed, maintenance-free 12V DC middle motor with flanged planetary gear and shaft outlet on both sides. Integrated control electronics for regulating speed and limit positions. Battery-aided 12V control with EWFS hand-held

radio transmitter, time logic function, 12V storage battery and solar panel. Upper and lower limit position adjustable.

Note: Control via weather station not possible!

Construction limit values for solar drive

	Width in mm	
	min.	max.
1 solar panel	760	according to table of construction limit values
2 solar panels	1300 ¹⁾	according to table of construction limit values

¹⁾ for solar panel on box.

Solar panel mounted alternatively right or left. Can optionally be supplied loose.

For gable areas with roof overhang we generally recommend installation in a location not shaded by a roof overhang or the like.

Mounting bracket for solar panel

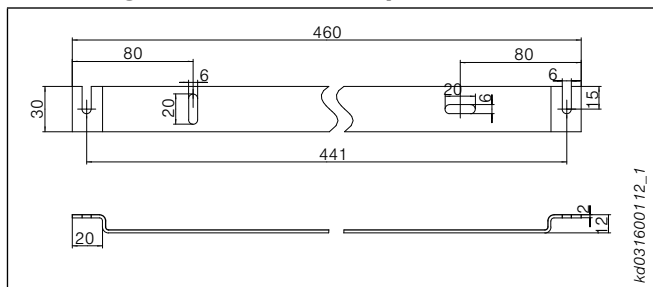

Fig. 146: Mounting bracket for external mounting of solar panel

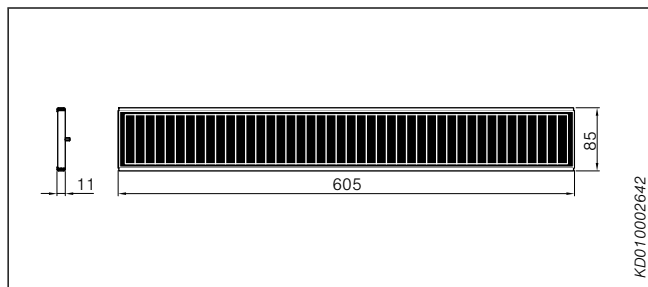

Fig. 147: Solar panel

For external mounting of the solar panel, the cable must be protected from UV radiation by installing the cable in a conduit or by similar protective measures.

Cable length on solar panel 2000 mm.

Table of construction limit values for solar drive¹⁾

In the calculation used as a basis, all areas north of a line running from Koblenz – Fulda – Chemnitz (or north of the 50.3° parallel) are regarded as central/northern Germany.

Table of maximum heights

Type	Width in mm									
	760	1000	1300	1500	1800	2000	2500	3000	3500	4000
E 80 A6	2600 (2250)	2600 (2100)	2600 (1950)	2600 (1800)	2250 (1750)	2050 (1650)	1750 (1550)	1450 (x)	1250 (x)	1100 (x)
E 73 A6	2600 (2200)	2600 (2000)	2600 (1850)	2400 (1800)	2100 (1700)	1900 (1600)	1600 (1500)	1350 (x)	1150 (x)	1050 (x)
E 80 AF	2600 (2400)	2600 (2200)	2600 (2000)	2600 (1950)	2600 (1800)	2400 (1800)	1950 (1600)	1650 (1550)	1400 (x)	1250 (x)

The indicated values are only valid for southern Germany. Solar drives are not possible for higher units.

Values in brackets are meant for northern and central Germany. Above these values up to maximum height a 2nd solar panel is required.

(x) For these widths and above a 2nd solar panel is also required for each type.

¹⁾ Sold exclusively in Germany, Austria and Switzerland.

Operation details

Front-mounted external venetian blinds R6/R10 Solar

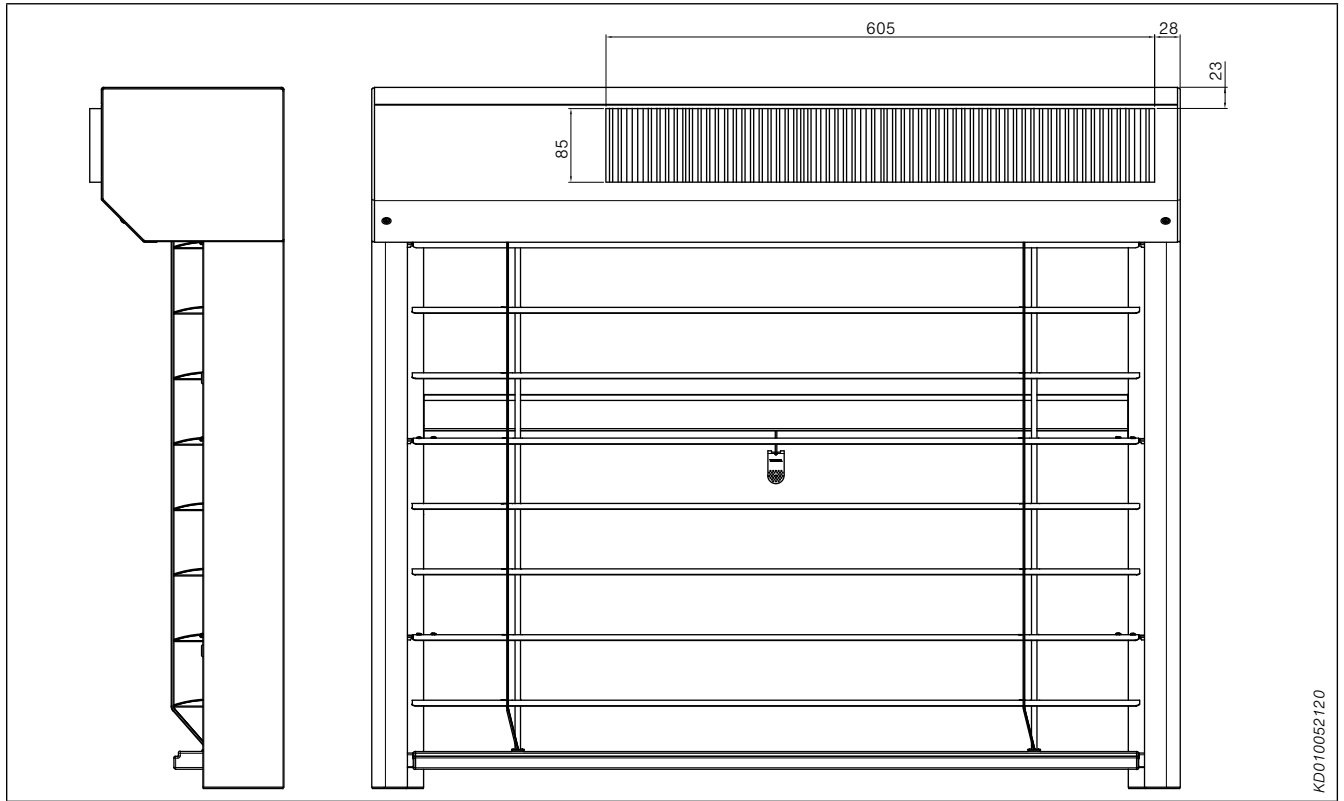

Fig. 148:

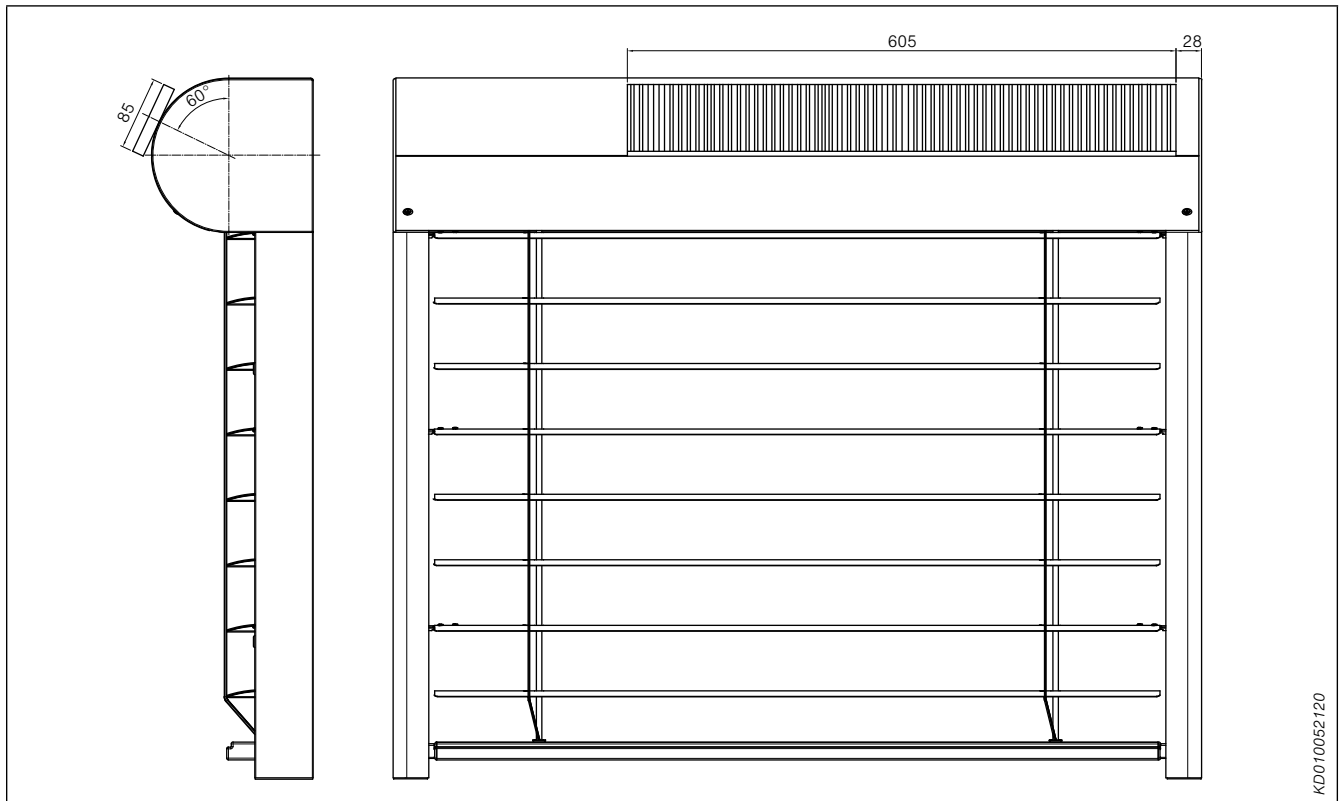

Fig. 149:

Contents

Accessories for front-mounted roller shutters

Cord operation	172
Belt operation	173
Crank operation	174
Guide rail brackets/distance brackets	176

Cord operation

Accessories for front-mounted roller shutters

Cord operation

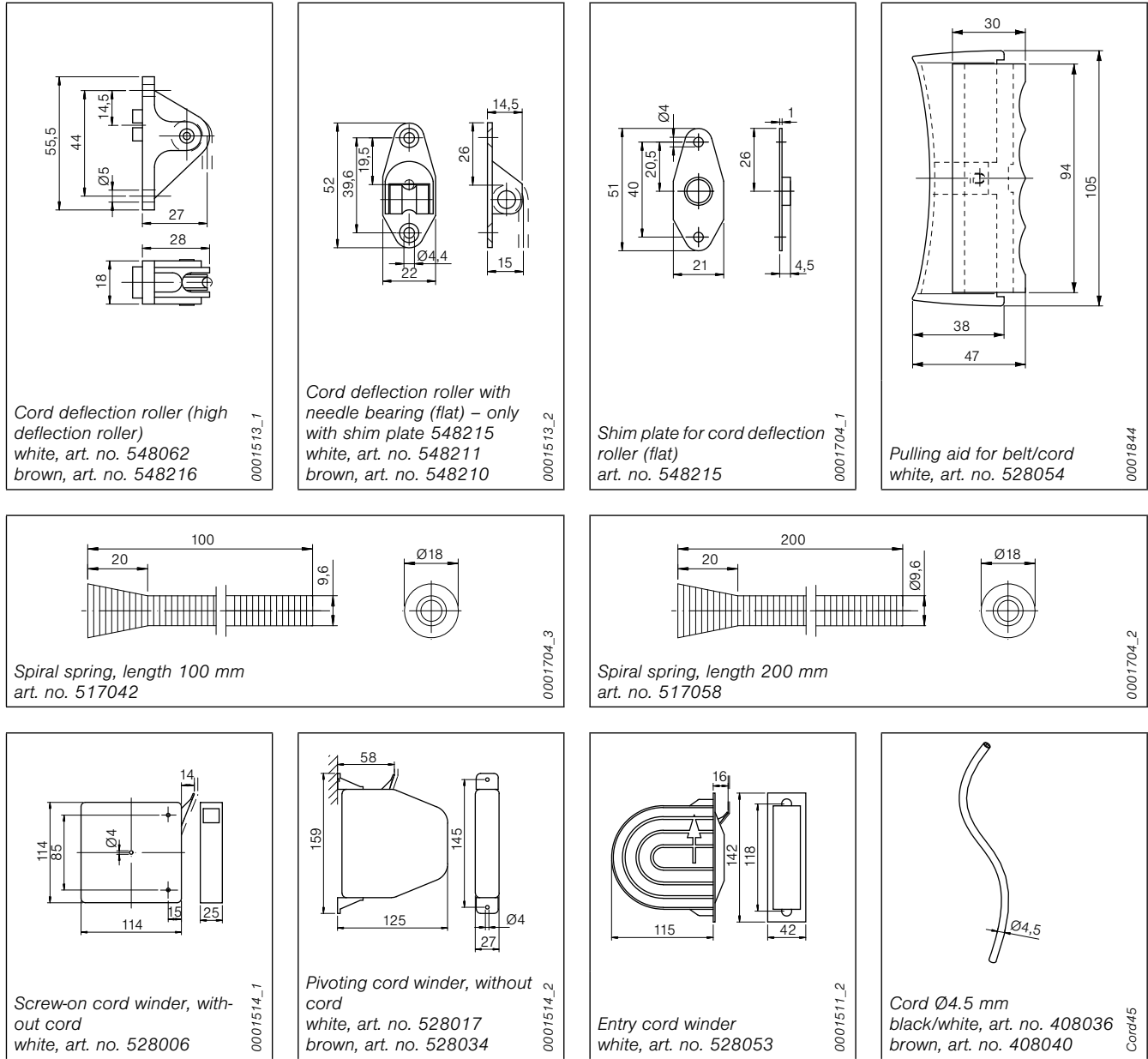

Fig. 150: Operating accessories for cord

Crank winder

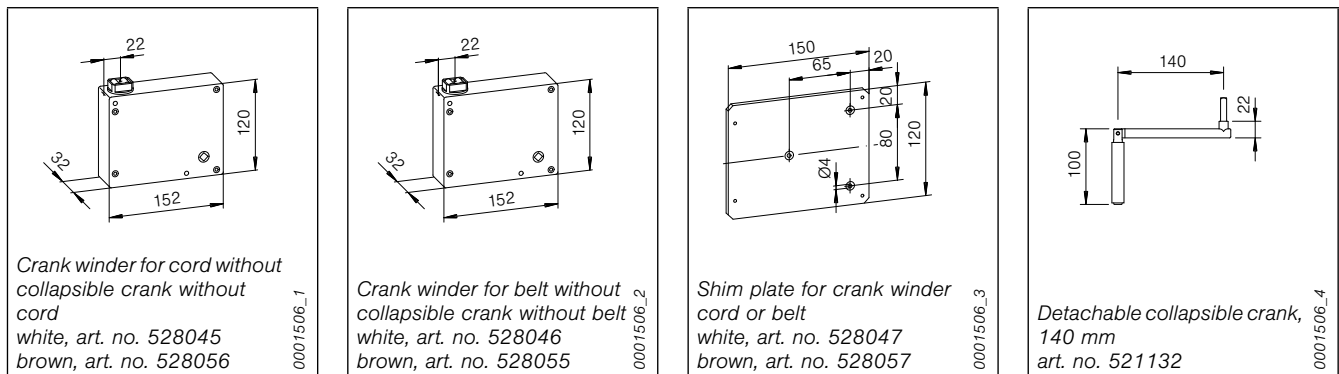

Fig. 151: Operating accessories for crank winder

Belt operation

 <p>Double deflection roller for belt deflection, type 6a white, art. no. 548156 brown, art. no. 548157</p> <p>0001509_1</p>	 <p>Brush guiding roller 14mm belt, Mini white, art. no. 548036 brown, art. no. 548037</p> <p>0001509_2</p>	 <p>Belt winder, flush mounted, 25 mm width, without belt white, art. no. 528001 brown, art. no. 528002</p> <p>0001510_1</p>	 <p>Belt winder, pivotable, without belt white, art. no. 528060 brown, art. no. 528061</p> <p>0001510_2</p>
 <p>Belt winder, pivotable without belt, for step-up gear (for 14 mm belt) white, art. no. 528020 brown, art. no. 528021</p> <p>0001511_1</p>	 <p>Belt winder, flush mounted, without belt white, art. no. 528004 brown, art. no. 528005 Cover plate white, art. no. 528007</p> <p>0001511_2</p>	 <p>Semi-embedded belt winder, without belt white, art. no. 528013 brown, art. no. 528014</p> <p>0001512</p>	 <p>Dowel-in guide roller 14 mm belt, art. no. 548140 23 mm belt, art. no. 548159</p> <p>w04383</p>
 <p>Washer 14mm belt, art. no. 548081 23mm belt, art. no. 548158</p> <p>KD030001899_1</p>	 <p>Plastic tube 500 mm Ø22, art. no. 548043 Ø32, art. no. 548160</p> <p>KD030001899_2</p>	 <p>Belt 14 mm grey, art. no. 404025 black/white, art. no. 404017 brown, art. no. 404018</p> <p>Belt 23 mm grey, art. no. 404010 brown, art. no. 404011</p> <p>0043</p>	 <p>Screw-on guide roller white, art. no. 548250 brown, art. no. 548249</p> <p>KD030002090_3</p>
 <p>Belt deflection type H Art. no. 548214</p> <p>KE032008 001</p>	 <p>Spacer element art. no. 548251</p> <p>KE031250012</p>		

Fig. 152: Operating accessories for belt

Crank operation

Accessories for front-mounted roller shutters

Crank operation

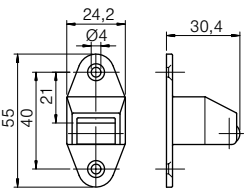
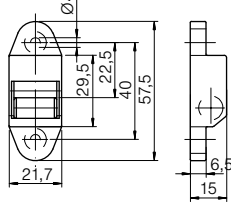
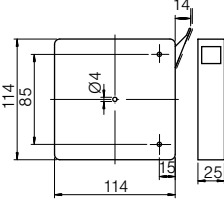
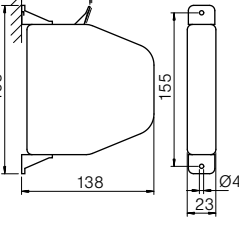
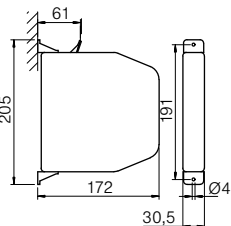
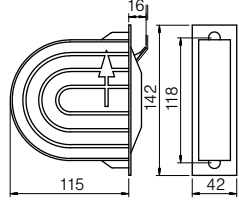
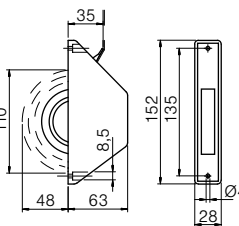
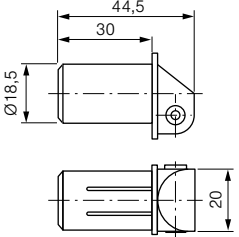
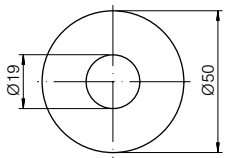
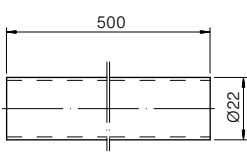
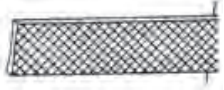
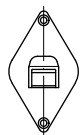
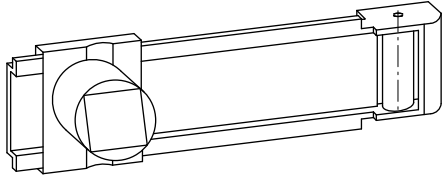
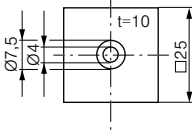
Joint plate, 22x85 mm, sealed, for horizontal gear outlet (0°-45°), square, 6 mm, 300 mm length, art. no. 525140
500 mm length, art. no. 525141
700 mm length, art. no. 525142

kd010002573

Joint plate, 22x52 mm, for vertical gear outlet (90°), square, 6 mm, 300 mm length
art. no. 525087

0001508_2

Crank rod, aluminium
C0
C34
RAL 9016
Crank rod, steel
grey

KE03 2007 003

Shim plate, chrome-plated, for joint plate 525086
40x85x2 mm
art. no. 521002

0001507

Shim plate, chrome-plated, for joint plate 525086
85x85x2 mm
art. no. 521001

0001507

Collapsible crank, aluminium grey, art. no. 521018
brown, art. no. 521019
white, art. no. 521045

KE03 2007 002

Collapsible crank, steel grey, art. no. 521017
white, art. no. 521198

KE03 2007 002

Crank holder
grey, art. no. 521055
brown, art. no. 521069
white, art. no. 521053

0001721

Crank holder with magnet (only available in combination with collapsible crank)
grey, art. no. 521034
white, art. no. 521221

0002047_3

Clamping sleeve for joint plate/crank (4x16)
art. no. 737047
for coupling funnel (4x20)
art. no. 737027

Coupling funnel
art. no. 521035

w00129

Fig. 153: Operating accessories for crank

Crank operation

Accessories for front-mounted roller shutters

Special joint plate

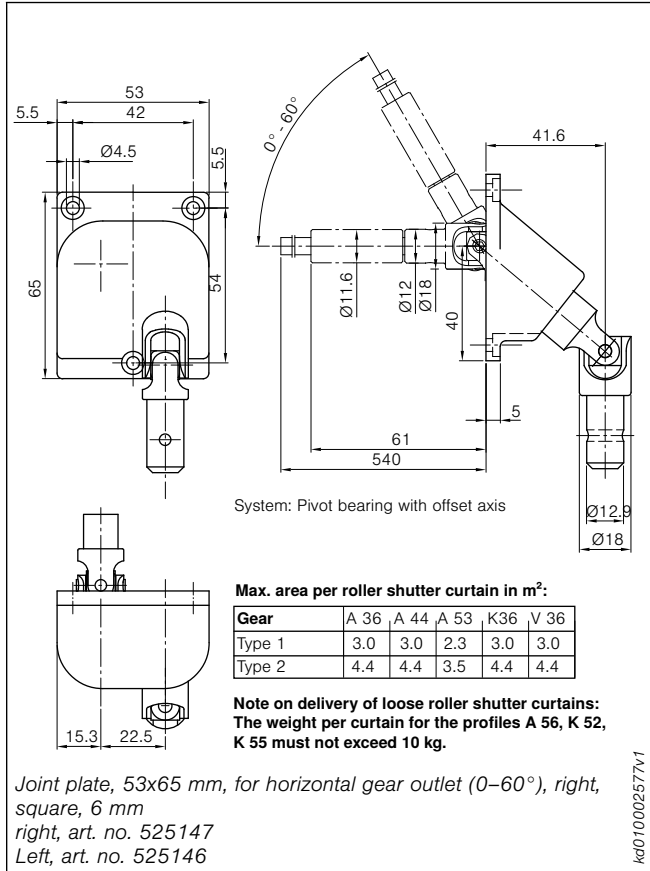

Fig. 154: Special joint plate

Order data for crank

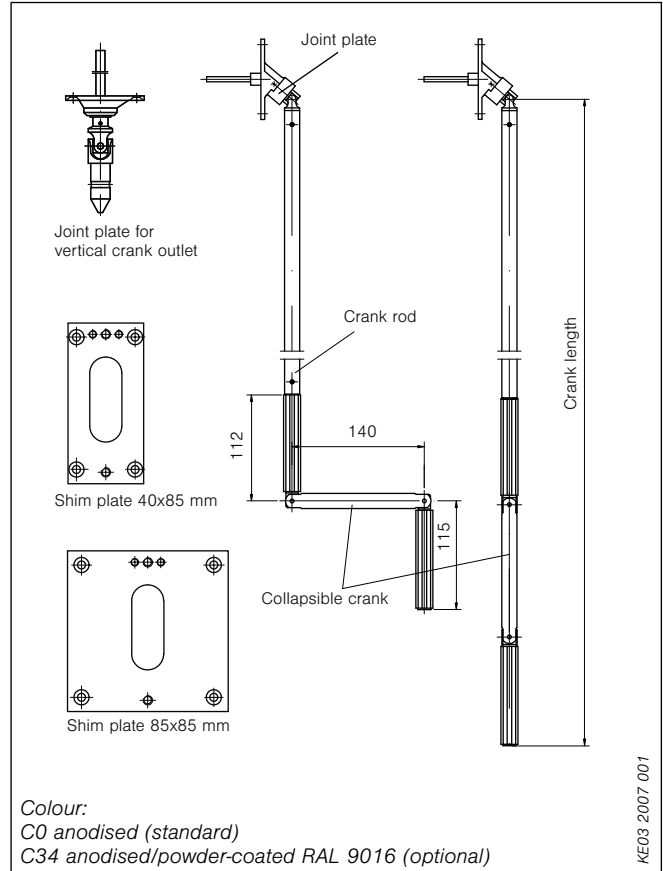

Fig. 155: Order data for crank

Guide rail brackets/distance brackets

Accessories for front-mounted roller shutters

Guide rail brackets (for mounting guide rails with distance)

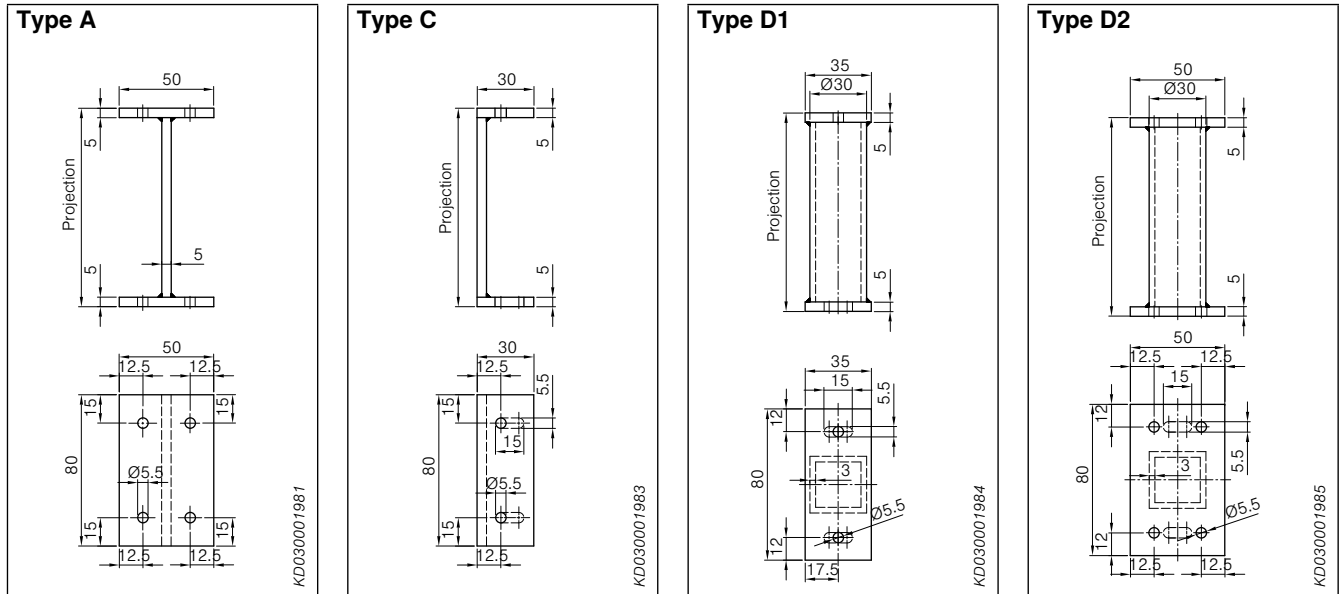

Fig. 156: Guide rail bracket

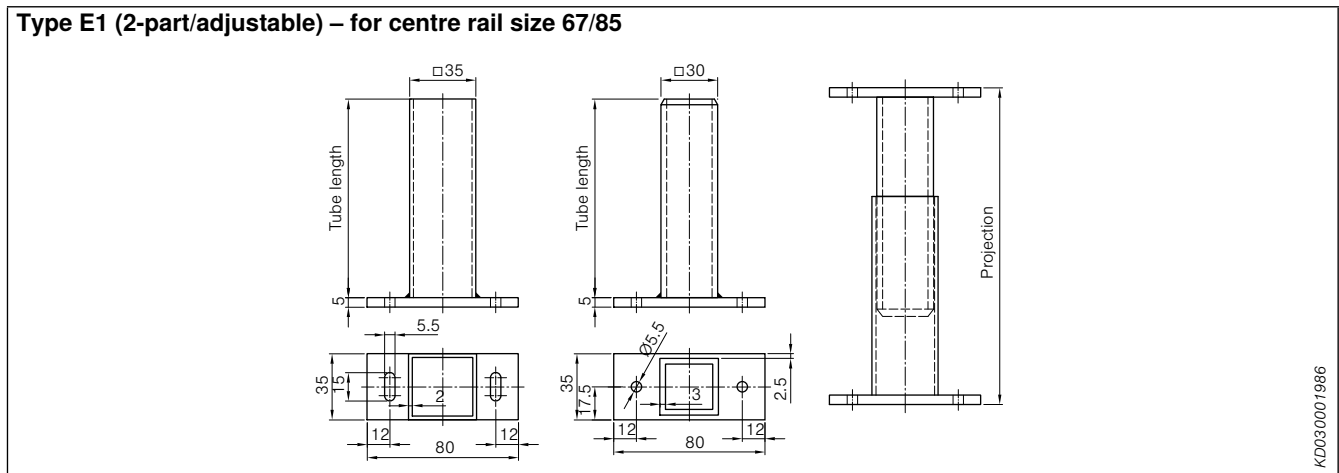

Fig. 157: Guide rail bracket (2-part/adjustable) – for centre rail size 67/85

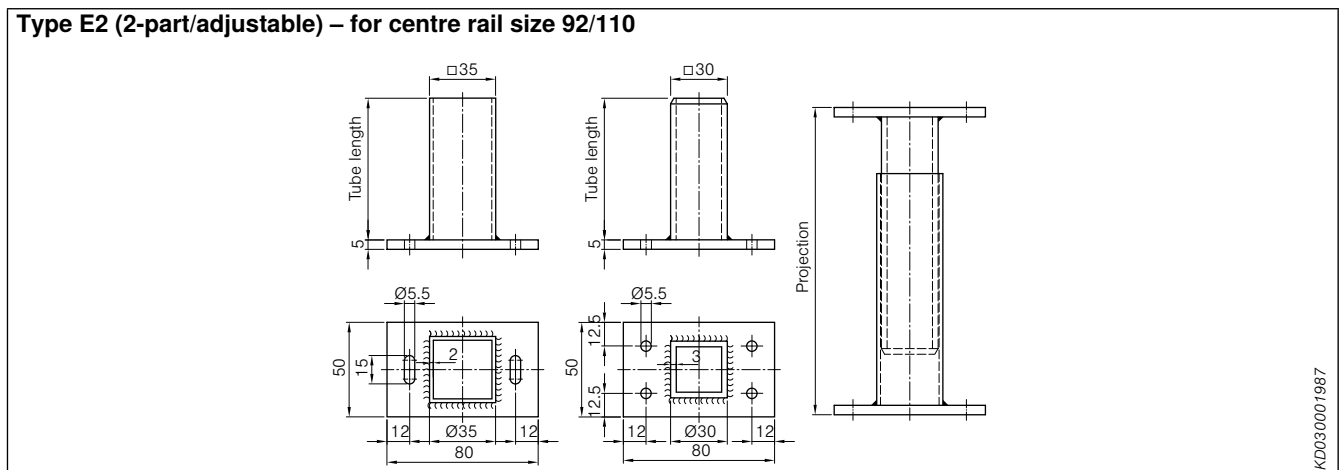

Fig. 158: Guide rail bracket (2-part/adjustable) – for size 92/110 centre rail

Contents

Roller shutter curtains

Construction limit values	178
Overview of roller shutter profiles/bale diameters	180
Overview of pressure springs	182
End rails	183

Please note:

As of now, information on the accessories for the installation of roller shutters for new buildings in on-site lintel boxes is available in a separate brochure. For an online version of this information, please use the sales material search for art. No. 253005.

Construction limit values
Aluminium roller shutter curtains

Maximum dimensions in mm – aluminium roller shutter curtains A 36, A 44, A 53, A 56 and S 37

Height	Width																																							
	900	1000	1100	1200	1300	1400	1500	1600	1700	1800	1900	2000	2100	2200	2300	2400	2500	2600	2700	2800	2900	3000	3100	3200	3300	3400	3500	3600	3700	3800	3900	4000	4100	4200	4300	4400	4500			
1000																				A 36, S 37						A 44		A 53											A 56	
1100																																								
1200																																								
1300																																								
1400																																								
1500																																								
1600																																								
1700																																								
1800																																								
1900																																								
2000																																								
2100																																								
2200																																								
2300																																								
2400																																								
2500																																								
2600																																								
2700																																								
2800																																								
2900																																								
3000																																								
3100																																								
3200																																								
3300																																								
3400																																								
3500																																								

The wind resistance class for each roller shutter profile can be found in the general information section on page 22 et seq.

Construction limit values

Plastic roller shutter curtains

Maximum dimensions in mm – plastic roller shutter curtains K 36, V 36, K 52 and K 55

Height	Width																											
	900	1000	1100	1200	1300	1400	1500	1600	1700	1800	1900	2000	2100	2200	2300	2400	2500	2600	2700	2800	2900	3000	3100	3200	3300			
1000												K 36	V 36				K 52										K 55	
1100																												
1200																												
1300																												
1400																												
1500																												
1600																												
1700																												
1800																												
1900																												
2000																												
2100																												
2200																												
2300																												
2400																												
2500																												
2600																												
2700																												
2800																												
2900																												
3000		K 36	V 36																									
3100																												
3200																												
3300																												
3400																												
3500	K 52																										K 55	

The wind resistance class for each roller shutter profile can be found in the general information section on page 22 et seq.

Overview of roller shutter profiles/bale diameters

Aluminium roller shutter curtains

Overview of roller shutter profiles

A 36 – aluminium, double walled, foam filled

Weight approx. 2.7 kg/m²
Profiles 28 units/m + end rail

KE03 2001 009V1

A 44 – aluminium, double walled, foam filled

Weight approx. 2.9 kg/m²
Profiles 23 units/m + end rail

KE03 2001 010

A 53 – aluminium, double walled, foam filled

Weight approx. 3.1 kg/m²
Profiles 18 units/m + end rail

KE03 2001 011

A 56 – aluminium, double walled, foam filled

Weight approx. 5.0 kg/m²
Profiles 18 units/m + end rail

KE03 2001 012

S 37 – aluminium, double walled, extruded

Weight approx. 6.3 kg/m²
Profiles 26 units/m + end rail

KE03 2001 004

Note:

- The stated roller shutter curtain weights do not include the end rail
- Overview of end rails see page 183.

Fig. 159: Overview of aluminium roller shutter profiles

Bale diameter in mm

Roller shutter profile	Shaft	Height of roller shutter curtain in mm												
		500	750	1000	1250	1500	1750	2000	2250	2500	2750	3000	3250	3500
A 36	SW40	90	100	110	115	125	140	150	150	160	160	170	195	215
	SW60	110	115	125	125	135	145	150	160	175	175	185	200	200
A 44	SW60	110	120	130	135	150	160	170	170	180	190	200	200	205
A 53	SW60	125	130	145	155	155	170	175	185	190	200	205	215	215
A 56	SW60	129	150	155	170	190	190	210	215	225	240	240	255	255
	SW70	140	160	180	180	200	200	220	220	235	240	255	270	275
S 37	SW60	115	120	130	140	150	155	166	170	180	185	190	205	225
	SW70	110	125	140	145	155	165	170	180	185	195	200	210	230

Note:

Shaft SW40 not available.

Overview of roller shutter profiles/bale diameters

Plastic roller shutter curtains

Overview of roller shutter profiles

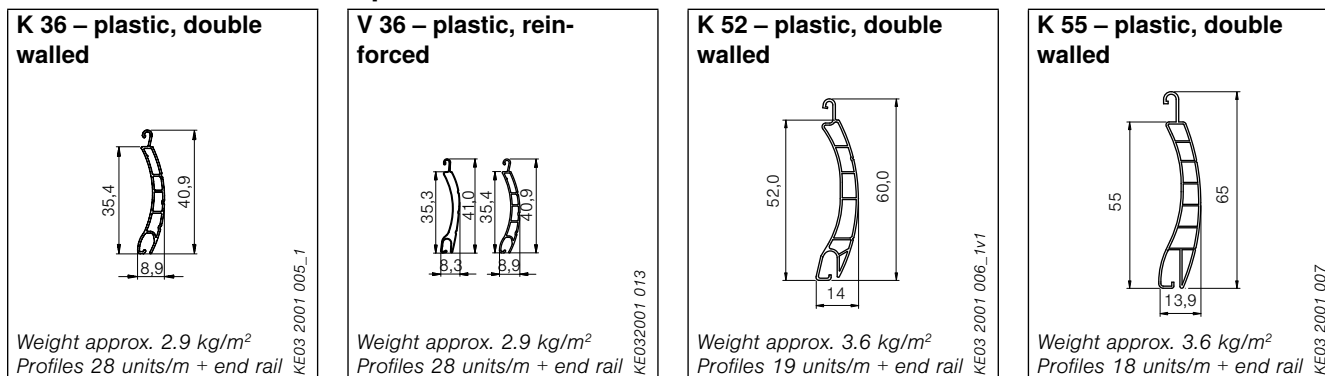

Fig. 160: Overview of plastic roller shutter profiles

Notes:

- The stated roller shutter curtain weights do not include the end rail
- Overview of end rails see page 183.

Bale diameter in mm

Roller shutter profile	Shaft	Height of roller shutter curtain in mm												
		500	750	1000	1250	1500	1750	2000	2250	2500	2750	3000	3250	3500
K 36	SW40	85	100	110	115	125	135	145	145	160	165	175	-	-
	SW60	100	110	125	130	130	145	155	155	165	170	170	-	-
V 36	SW40	90	105	115	120	130	140	150	150	165	170	180	-	-
	SW60	105	115	130	135	140	150	160	165	175	180	185	-	-
K 52	SW60	120	130	130	140	165	165	180	185	200	200	215	215	225
	SW70	-	-	-	-	-	-	-	-	-	-	-	-	-
K 55	SW60	135	135	140	170	170	185	185	195	210	210	225	235	235
	SW70	120	140	155	160	170	200	200	210	210	220	230	230	255

Note:

Shaft SW40 not available.

Overview of pressure springs

Roller shutter curtains

Overview of pressure springs

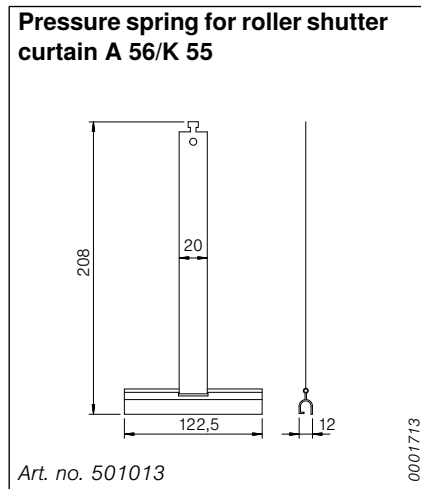
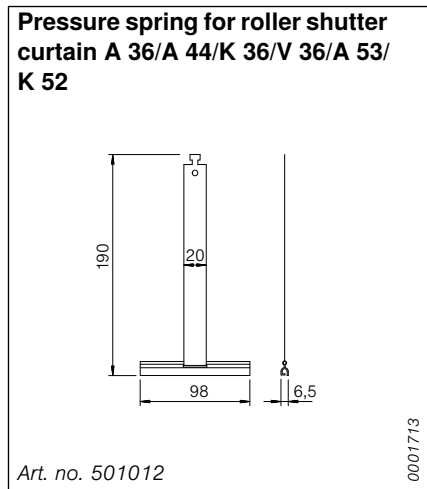

Fig. 161: Overview of pressure springs

Roller shutter curtains	Pressure springs in relation to width of roller shutter curtain in mm									
	800	1200	1600	2000	2400	2800	3200	3600	4000	4500
A 36	2	3	4	5	6	7	8	–	–	–
A 44	2	3	4	5	6	7	8	9	–	–
A 53	2	3	4	5	6	7	8	9	–	–
A 56	2	3	4	5	6	7	8	9	10	11
K 36	2	3	4	5	–	–	–	–	–	–
V 36	2	3	4	5	6	–	–	–	–	–
K 52	2	3	4	5	6	7	–	–	–	–
K 55	2	3	4	5	6	7	8	9	–	–

End rails

Roller shutter curtains

Notes:

- Flat end rails are used as a standard; two-piece angled end rails optionally available
- End rails without sealing strip as a standard, optionally with sealing strip
- Two-piece angled end rails are supplied with a stop square with 40 mm distance as a standard.
 - Offset of stop square per side 24 mm, 32 mm, 43 mm or 63 mm
 - The offset value depends on the type of guide rail
 - If no other value is stated we will assume an offset of 32 mm

Flat end rails

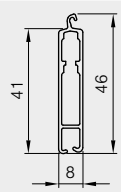
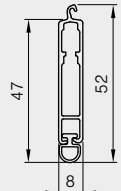
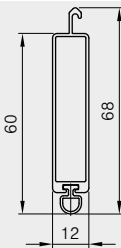
End rail type	possible roller shutter curtain								
	A36	A44	A53	A56	S37	K36	V36	K 52	K55
 <p>without sealing strip</p>	●	●	-	-	●	●	●	-	-
 <p>with sealing strip</p>	○	○	-	-	○	○	○	-	-
 <p>with sealing strip</p>	-	-	●	●	-	-	-	●	●

Legend:

- standard
- optionally possible
- not possible

Stop square for flat end rail, 40 mm projection
standard for belt and crank

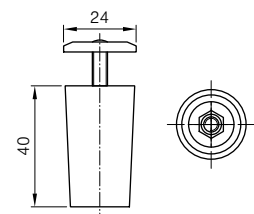

Art. No. 2001074 – grey
Art. No. 2001075 – white
Art. No. 2001076 – brown

KD031900088v2

Fig. 162: Vertical belt outlet

End rails

Roller shutter curtains

Two-piece angled end rail (optional)

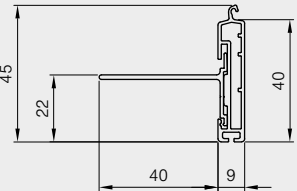
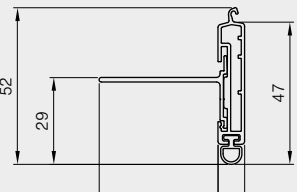
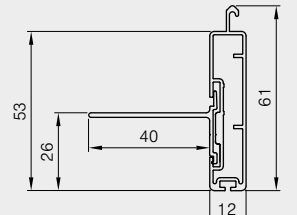
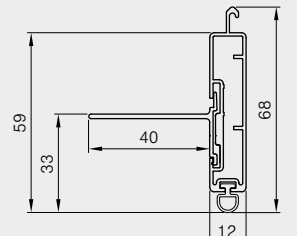
End rail type	possible roller shutter curtain									
	A36	A44	A53	A56	S37	K36	V36	K 52	K55	
 <p>without sealing strip</p>	●	●	-	-	●	●	●	-	-	
 <p>with sealing strip</p>	○	○	-	-	○	○	○	-	-	
 <p>without sealing strip</p>	-	-	●	●	-	-	-	●	●	
 <p>with sealing strip</p>	-	-	○	○	-	-	-	○	○	

Legend:

- standard
- optionally possible
- not possible

Contents

Control systems

Function overview.	186
WMS – WAREMA Mobile System.	188
EWFS – standardised WAREMA radio system.	189
WAREMA Minitronic dialog.	190
WAREMA Timer and WAREMA Comfort Timer.	191
WAREMA climatronic®	192
WAREMA Wisotronic	193

Everything at a glance

Function overview

		Radio systems		Central control systems		
		EWFS	WMS	WAREMA Timer	WAREMA Comfort timer	Time switch
Product description		Additional information can be found in the document Control system technical documentation / purchase prices				
Control channels		1/ 8	96	1	1	1
Transmission frequency		433.92 MHz	2.4 GHz	–	433.92 MHz	–
EWFS compatible		●	–	–	●	–
Automatic presets for different sun shading products		–	●	–	–	–
Safety functions	Wind monitoring (max. connectible sensors)	●	●	–	–	–
	Evaluation of wind direction	–	–	–	–	–
	Precipitation monitoring	●	●	–	–	–
	Ice monitoring	–	●	–	–	–
Energy efficiency/comfort functions	Sun control	●	●	–	–	● ²⁾
	Dawn/dusk control	–	●	● ³⁾	● ^{2) 4)}	● ²⁾
	Time switch	●	●	●	●	●
	Control timer	–	–	–	–	–
	Temperature control with inside temperature sensor	–	–	–	–	–
	Temperature control with outside temperature sensor	–	●	–	–	–
	Automatic differential temperature control	–	–	–	–	–
	Humidity control	–	–	–	–	–
	Adjustable awning run time	–	●	●	●	●
	Window control	–	●	–	–	–
	Intermittent ventilation	–	–	–	–	–
	Slat tilting	–	●	–	●	–
	Slat tracking	–	–	–	–	–
	Radio clock (DCF77)	–	–	–	–	–
	Dimming of light	●	–	–	–	–
	Fan control	–	–	–	–	–
	Astro function	–	●	●	●	–
	Scenes	–	–	–	–	–
	Occupancy simulation	–	–	●	●	–
	History of measuring values and trigger events	–	–	–	–	–
Operation	Mobile remote control	●	●	–	●	–
	Central unit/wall-mounted transmitter	●	●	●	●	●
	External channel push button connectible	–	–	–	–	–
	PC	–	–	–	–	–
	Control via BSC	–	–	–	–	–
Commissioning	online via PC	–	–	–	–	–
	offline via PC	–	●	–	–	–







- possible
- not possible

¹⁾ Weather station multisense is included in the max. number of sensors

²⁾ Optional photo sensor with suction cup for window pane

³⁾ Integrated astro function

⁴⁾ Optional dawn/dusk sensor with suction cup for window pane

Central control systems				WAREMA climatronic®	Bus systems	
Minitronic dialog	Wisotronic 1 channels	Wisotronic 2/3/4 channels	Quatronic dialog	WAREMA climatronic®	KNX	LonWorks®
						
Additional information can be found in the document Control system technical documentation / purchase prices						
1	1	2-4	4	64	any number	any number
433.92 MHz	433.92 MHz	433.92 MHz	-	433.92 MHz	433.92 MHz	433.92 MHz
●	●	●	-	●	●	●
-	●	●	●	●	●	●
1	1	4 ¹⁾	4	12	●	●
-	-	-	-	●	●	●
●	●	●	●	●	●	●
-	●	●	●	●	●	●
-	●	●	●	●	●	●
-	●	●	●	●	●	●
-	●	●	●	●	●	●
-	●	●	●	●	●	●
-	●	●	-	●	●	●
-	-	-	●	●	●	●
●	●	●	●	●	●	●
-	●	●	-	●	●	●
-	●	●	●	●	●	●
-	-	-	-	●	●	●
-	-	-	-	●	●	●
-	-	-	-	●	●	●
-	●	●	-	●	●	●
-	-	-	-	●	●	●
-	●	●	-	●	●	●
●	●	●	-	●	●	●
●	●	●	●	●	●	●
-	●	●	●	●	●	●
-	-	-	-	●	●	●
-	-	●	●	●	●	●
-	-	-	-	●	●	●
-	-	-	-	●	●	●

● possible
- not possible

¹⁾ Weather station multisense is included in the max. number of sensors
²⁾ Optional photo sensor with suction cup for window pane
³⁾ Integrated astro function
⁴⁾ Optional dawn/dusk sensor with suction cup for window pane

Description

WMS – WAREMA Mobile System

WMS – mobile control for discerning requirements

The WAREMA Mobile System unites modern technology and aesthetic design in a radio remote control for discerning requirements. In the WAREMA Mobile System the only components needed are the transmitter and receiver. Distant products can also be reached by transmitting commands from receiver to receiver (routing function). Users receive feedback about all move commands of their sun shading systems.

System components



- 1 WMS hand-held transmitter
- 2 WMS central transmitter
- 3 WMS weather station eco
- 4 WMS weather station plus
- 5 WMS flush mounted receiver/transmitter
- 6 WMS plug receiver
- 7 WMS power socket
- 8 WMS wind sensor for patio awnings
- 9 WMS stick with free WMS software

Features

- transmission frequency: 2.4 GHz
- control of sun shading products on up to 96 channels
- offers maximum protection against unauthorised controlling
- control functions:
 - brightness
 - wind
 - precipitation
 - time
 - dawn/dusk
 - outside temperature
 - ice monitoring

Benefits

- larger range through intelligent routing function
- optical feedback of the executed move command
- scene control for up to 32 different scenes
- move to individual comfort positions at the press of a button
- commissioning and changing of limit values possible via PC
- individual expansion of the control with minimum installation work
- window control possible

Typical applications

- one-family houses
- multiple occupancy buildings
- renovation
- retrofitting

Operating principle

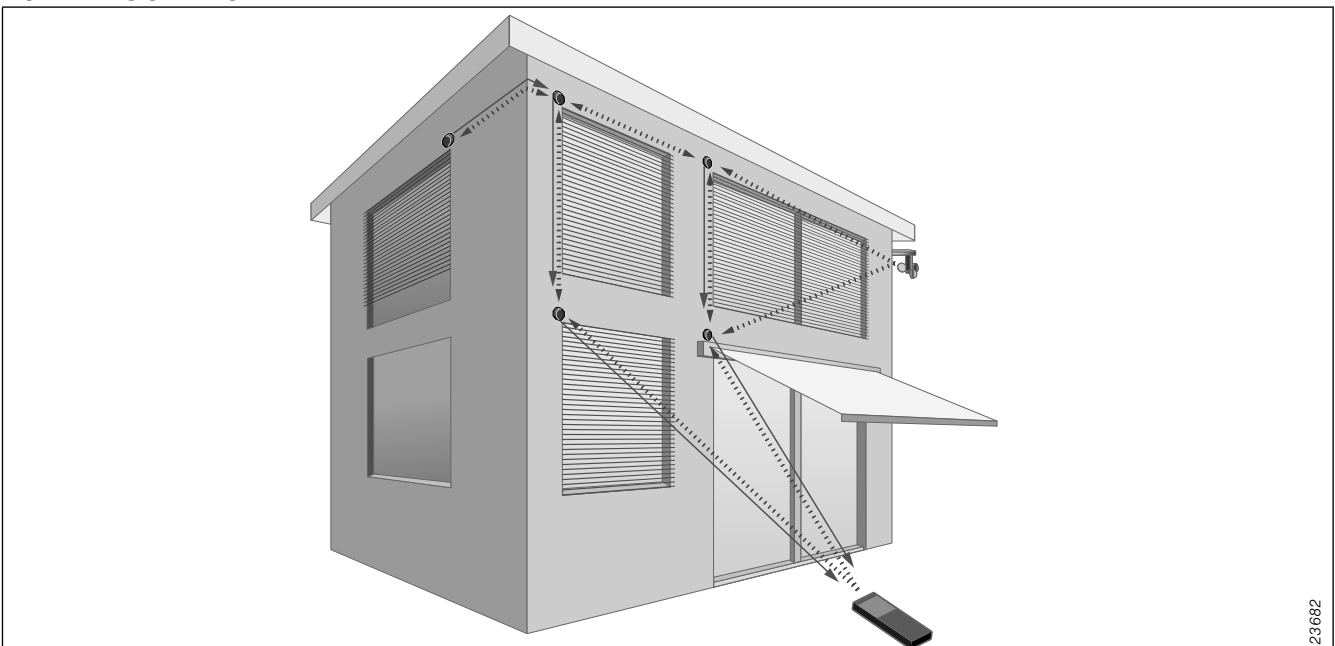

Fig. 163: Intelligent routing function transfers move commands to distant devices

Description

EWFS – standardised WAREMA radio system

EWFS – flexible radio control for your sun shading systems

EWFS, the standardised WAREMA radio system, is used for remote controlling of sun shading and lighting. Using the control is just as comfortable and easy as e.g. operating your TV set. EWFS solutions are particularly practical for expansion and retrofitting: Wireless components and various control options allow subsequent expansion of your individual sun shading system with minimum installation work.

System components



- 1 EWFS timer
- 2 EWFS wall-mounted transmitter
- 3 EWFS hand-held transmitter
- 4 EWFS weather station eco
- 5 EWFS weather station plus
- 6 EWFS plug receiver
- 7 EWFS flush mounted receiver

Features

- transmission frequency: 433.92 MHz
- one EWFS transmitter controls any number of receivers
- control functions:
 - brightness
 - Wind
 - precipitation
 - time
 - dawn/dusk using astro function

Benefits

- ideal for expanding and retrofitting
- individual expansion of the control with minimum installation work
- convenient radio remote control of sun shading units
- switching and dimming of light possible
- simultaneous operation of several receivers by pressing just one button
- complete product range for controlling sun shading products such as external venetian blinds, awnings or roller shutters
- additional components available for expansion, e.g. radiant heater control for patio awnings

Typical applications

- one-family houses
- renovation
- retrofitting

Operating principle

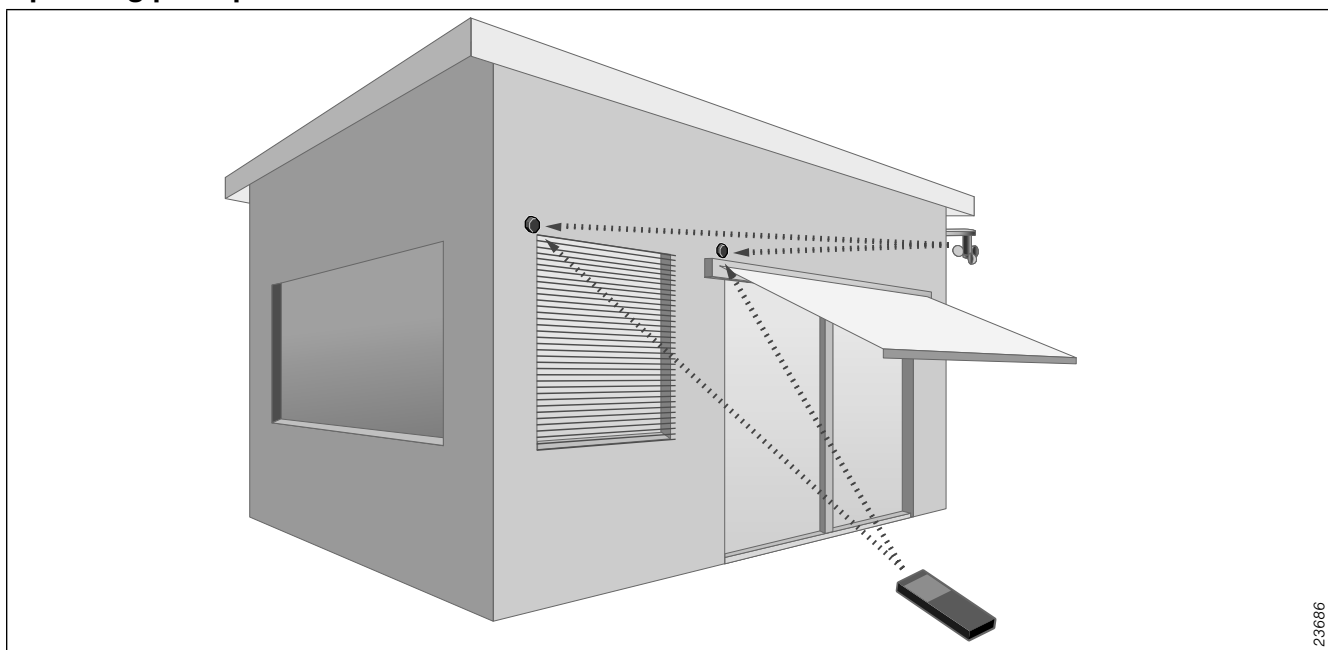

23686

Fig. 164: Operating principle EWFS

Description

WAREMA Minitronic dialog

Minitronic dialog – setting awnings and external venetian blinds in motion

The central control unit Minitronic dialog was specially designed for awnings and external venetian blinds. When the sun is uncomfortably bright the sun shading system is automatically moved into position while you relax in the shade. During strong wind and rain Minitronic dialog protects your awnings and external venetian blinds against damage.

Installation suggestion



1 Minitronic dialog

Features

- mounting in standard switch box
- operation via EWFS hand-held or wall-mounted transmitter possible
- control functions:
 - brightness
 - Wind
 - precipitation

Benefits

- tilting the external venetian blind slats at the central control unit or conveniently using the EWFS hand-held transmitter
- preset parameters prevent overheating of the building and protect the sun shading system against damage from wind and precipitation
- easy setting and changing of limit values on the display

Typical applications

- one-family houses
- new buildings
- renovation

Wiring diagram

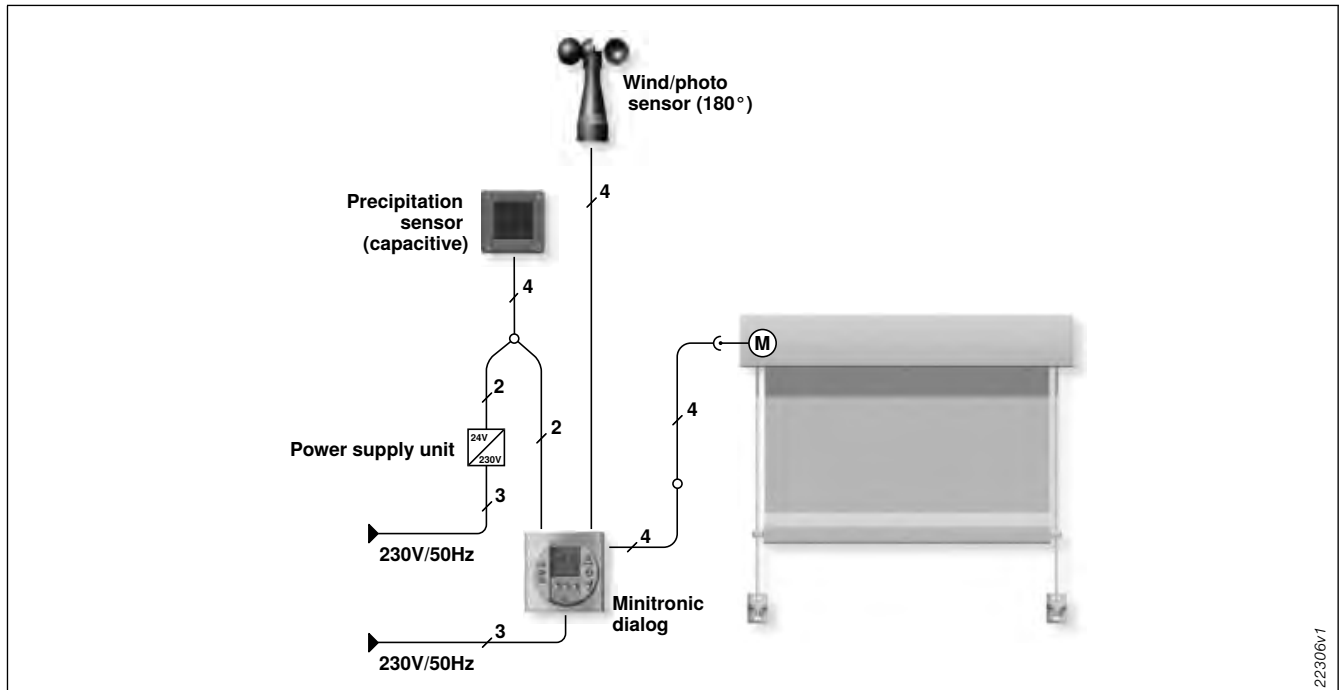

Fig. 165: Wiring diagram Minitronic dialog

Description

WAREMA Timer and WAREMA Comfort Timer

WAREMA Timer and WAREMA Comfort Timer – time controlled

WAREMA Timer and WAREMA Comfort Timer provide reliable control for your sun shading system according to time and dusk/dawn data. The best possible reaction to summer midday sun or bitterly cold winter nights also reduces your energy costs and improves the climate in the building. Efficient occupancy simulation protects your property against unwanted intruders.

Features

- mounting in standard switch box
- radio operation via EWFS hand-held or wall-mounted transmitter possible
- floating output allows direct control of the sun shading drive independent of the required voltage
- timer: programmable for individual weekdays, weekend and the entire week
- control functions:
 - time
 - dawn/dusk

Installation suggestion

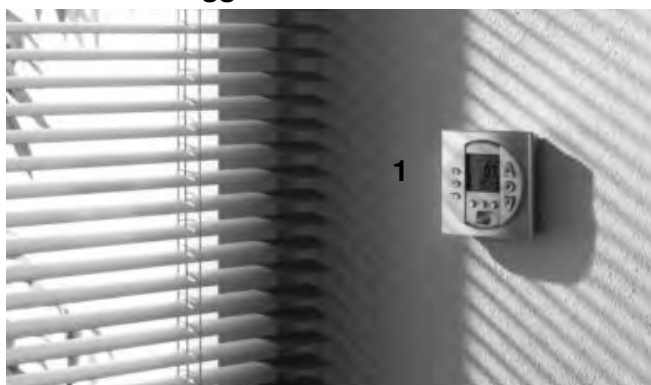

1 WAREMA Timer

Benefits

- intelligent occupancy simulation – the house appears occupied even when you are not at home and is protected against burglars
- automatic switching between summer and winter time
- astro function optimally adapts move commands to dawn/dusk times

Typical applications

- one-family houses
- new buildings
- renovation

Wiring diagram

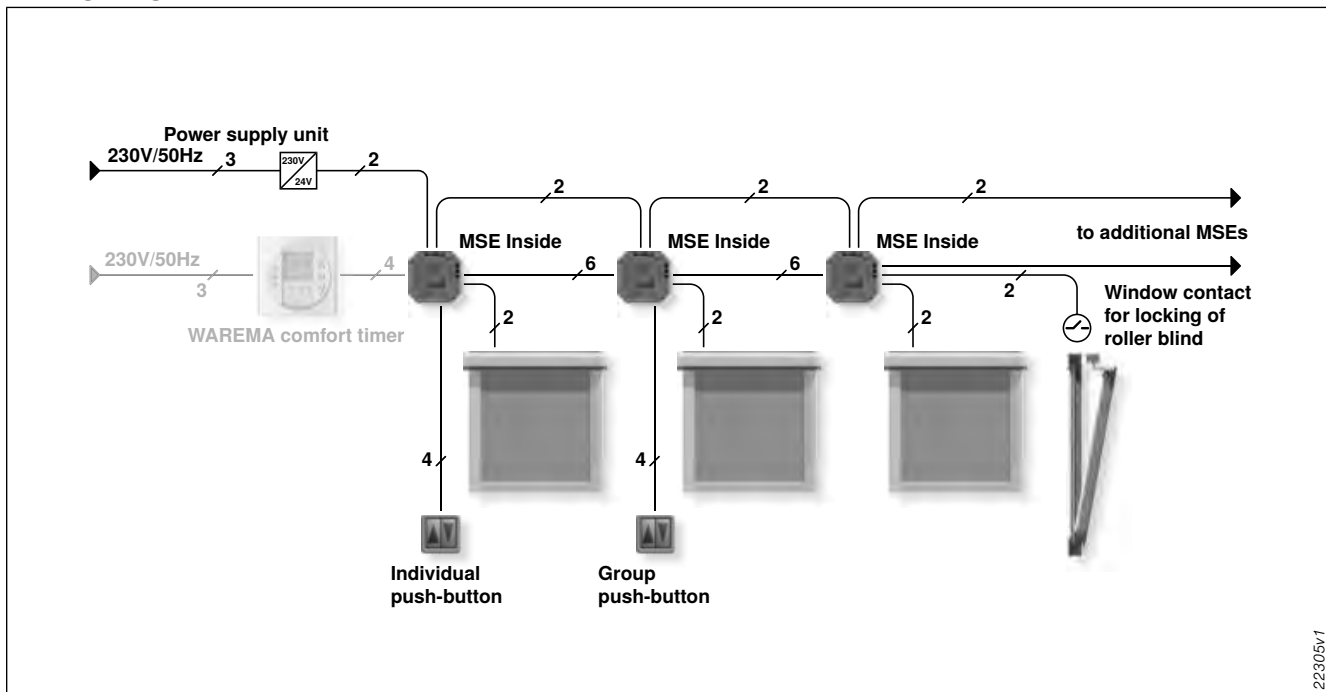

22305v1

Fig. 166: Wiring diagram WAREMA Timer

Description

WAREMA climatronic®

WAREMA climatronic® – a complete control system for an ideal climate

WAREMA climatronic® coordinates your sun shading system with heating, air conditioning and ventilation systems to create the best possible room climate. In smaller and larger buildings it monitors and controls according to environmental influences which have an effect on your well-being. Humidity, temperature or light intensity are controlled according to your preset values. Intuitive operation makes it easy to create your personal preferred climate for working and relaxing.

System components



- 1 WAREMA climatronic® control panel
- 2 WAREMA climatronic® switch actuator for installation in electric distribution box
- 3 EWFS hand-held transmitter

Features

- channels can be operated via EWFS transmitter
- up to 7200 individual products are controlled on 64 channels in individual or group circuits
- operating panel with control wheel, sensor keys, glass front and 3.5" TFT colour display
- temperature and humidity sensors are already integrated into the operating panel

Benefits

- slat tracking according to sun position allows best possible light gain and prevents direct glare
- switching and dimming of light possible
- up to 16 channels can be set
- settings using free software and operating panel:
 - convenient adjustment at any time
 - can be saved to and loaded from an SD card
 - prevents re-wiring when user requirements change
- using the operating panel as KNX central control unit via KNX Gateway
- use as KNX central control unit requires no commissioning tool and allows user changes

Typical applications

- one-family houses
- multiple occupancy buildings
- office buildings
- new buildings
- renovation

Wiring diagram

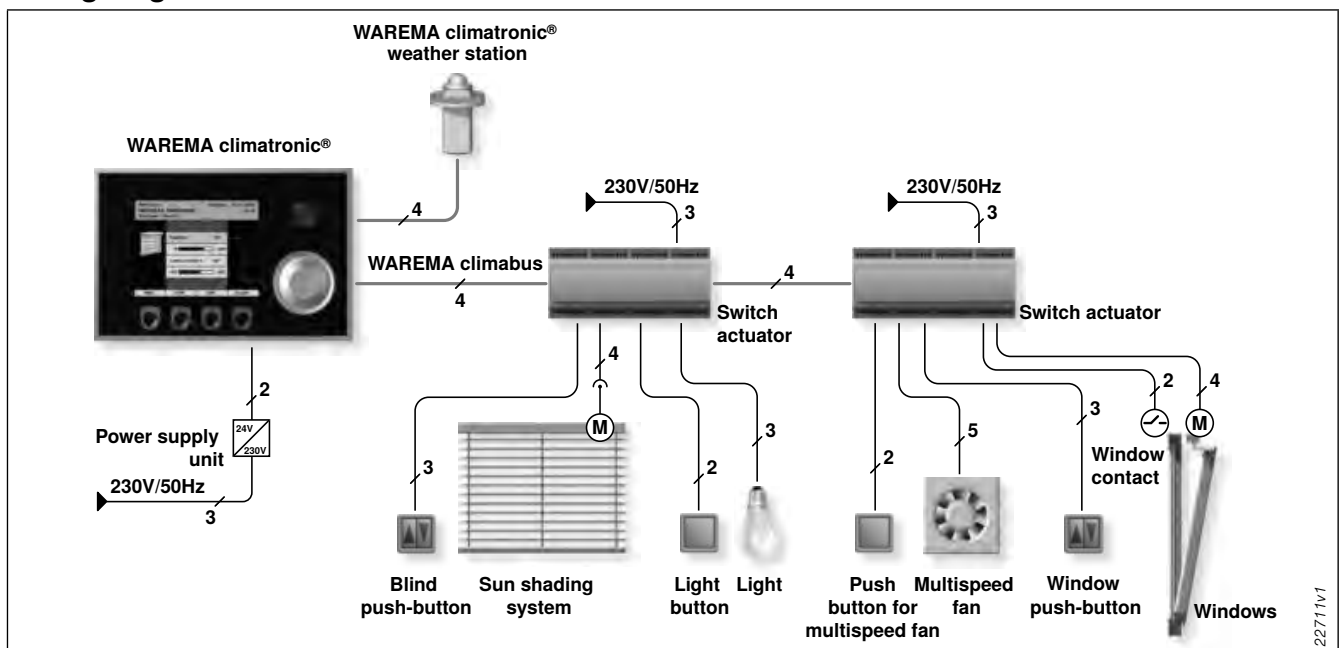

Fig. 167: Wiring diagram WAREMA climatronic®

Description

WAREMA Wisotronic



Wisotronic – visual accents and ingenious functionality

Wisotronic is an intelligent control system for your individual sun shading combination. It is suitable for all WAREMA products and at home in various environments. The control system provides a comfortable room climate and a pleasant living or working environment, even when you are busy or not at home. The design provides visual highlights – it received the iF product design award 2012.

System components



- 1 Wisotronic operating panel
- 2 Wisotronic power unit surface mounted
- 3 Wisotronic power unit rail mounted
- 4 Weather station multisense
- 5 EWFS hand-held transmitter

Features

- operation via EWFS hand-held or wall-mounted transmitter possible
- 1-4 channels for controlling different sun shading products or facade sides

- different mounting options possible for the operating panel (surface mounted, set in plaster or almost flush)
- control functions:
 - brightness
 - wind
 - precipitation
 - time
 - inside/outside temperature
 - dawn/dusk
 - ice monitoring
 - different ventilation functions for electrically operated windows

Benefits

- high-gloss surface provides visual highlights in the living area
- operating panels available in black or white
- 4 adjustable scenes create an individual feel-good atmosphere
- temperature sensor integrated into the operating panel
- weather data such as temperature or wind speed displayed on the operating panel
- integrated timer
- integrated ice monitoring protects sun shading products against damage
- easy commissioning using the quick start menu (ready for operation after 5 settings)
- system can be expanded or extended at any time

Typical applications

- one-family houses
- multiple occupancy buildings
- office buildings
- new buildings
- retrofitting

Wiring diagram

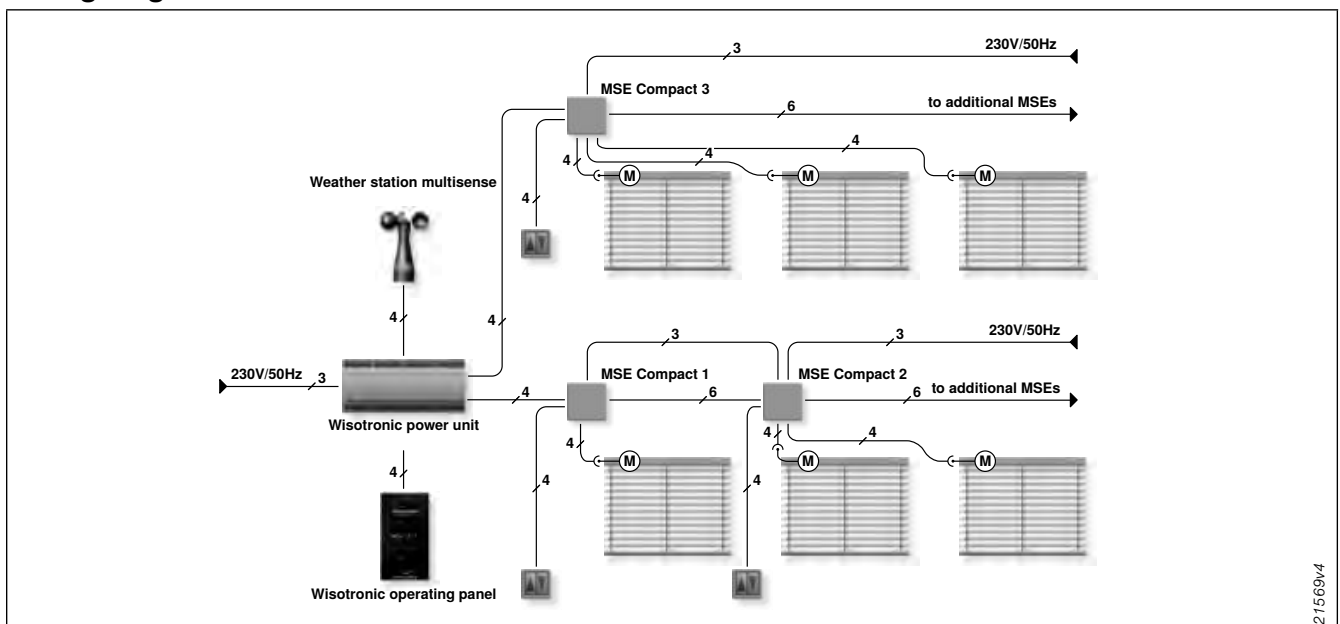

Fig. 168: Wiring diagram Wisotronic

A		E	
Additional box fastening		End lockings for guide rails	118
Front-mounted external venetian blinds	157	End rails	
Front-mounted roller shutters	97	Front-mounted roller shutters	119
Adjusting/measuring insect screen		End rails with locking device	
Front-mounted external venetian blinds R6/R10	149	Front-mounted roller shutters	120
Area diagram		EWFS – standardised WAREMA radio system	189
Front-mounted roller shutters V10	61		
Front-mounted roller shutters V4	41	G	
Front-mounted roller shutters V6	51	Guide rail brackets/distance brackets	
B		Accessories for front-mounted roller shutters	176
Belt operation		Guide rails	
Accessories for front-mounted roller shutters	173	Front-mounted external venetian blinds R10	146
Box dimensions		Front-mounted roller shutters with Minimax guide rails	115
Front-mounted external venetian blinds R10	145	Front-mounted roller shutters with reinforced guide rails	116
Front-mounted external venetian blinds R6	138	Guide rails for front-mounted roller shutters	108
Front-mounted roller shutters V10	62	Guide rails/end rail	
Front-mounted roller shutters V4	43	Security roller shutter FR23/FR24	129
Front-mounted roller shutters V6	52		
Security roller shutter FR23/FR24	127	I	
Box extension		Insect screen swivel frame	
Front-mounted external venetian blinds R6/R10	153	Front-mounted external venetian blinds R10	150
Box extensions			
Front-mounted roller shutters	99	L	
C		Locking device for end rails	
Certificate for security roller shutters FR 23/FR 24	130	Front-mounted roller shutters	120
Colours for roller shutter profiles/external venetian blind slats	17		
Construction limit values		M	
Aluminium roller shutter curtains	178	Measuring instructions for front-mounted roller shutters	
Front-mounted external venetian blinds R10	143, 144	Mounting in the reveal/guide rails with diagonal cut	68
Front-mounted external venetian blinds R6	137	Minimax guide rails	94
Front-mounted roller shutters V10	59, 60	Motor operation details	
Front-mounted roller shutters V4	39, 40	Front-mounted roller shutters	92
Front-mounted roller shutters V6	49	O	
Plastic roller shutter curtains	179	Operating classes according to DIN EN 13659	24
Security roller shutter FR23/FR24	124	Operation details	
Cord operation		Front-mounted external venetian blinds – motor operation	165
Accessories for front-mounted roller shutters	172	Front-mounted external venetian blinds R6/R10	163
Cord operation details		Front-mounted external venetian blinds R6/R10 Solar	168
Front-mounted roller shutters	89	Security roller shutter FR23/FR24	126
Crank operation		Order data for combinations	
Accessories for front-mounted roller shutters	174	Front-mounted external venetian blinds R6/R10	152
Crank operation details		Outlet gap closed for models without insect screen	
Front-mounted roller shutters	90	Front-mounted roller shutters	98
D		Overview of accessories/equipment	30
Description		Overview of pressure springs	
Front-mounted external venetian blinds R10	140	Roller shutter curtains	182
Front-mounted external venetian blinds R6	134	Overview of roller shutter profiles/bale diameters	
Front-mounted external venetian blinds R6/R10 Solar	168	Aluminium roller shutter curtains	180
Front-mounted roller shutters V10	56	Plastic roller shutter curtains	181
Front-mounted roller shutters V4	36	P	
Front-mounted roller shutters V6	46	Pressure springs	
Security roller shutter FR23/FR24	122	Roller shutter curtains	182
Details of belt operation		Q	
Front-mounted roller shutters	84	Quick installation kit	96
Details of belt/cord operation with crank winder			
Front-mounted roller shutters	88	R	
Determining dimensions/order data		Requirements for external sun shading systems	26
Front-mounted roller shutter V10 solar	80		
Front-mounted external venetian blinds R6/R10	147	S	
Front-mounted roller shutter with insect screen roller blind	74	Sealing strips for guide rails	
Front-mounted roller shutter with insect screen swivel frame	76	Front-mounted roller shutters	117
Front-mounted roller shutter with Minimax guide rails and insect screen swivel frame	79	Security package in accordance with DIN 18073	95
Front-mounted roller shutters V10	72	Service and quality	19
Front-mounted roller shutters V4/V6	69	Solar drive adjustment	
Security roller shutter FR23/FR24	125	Front-mounted external venetian blinds R6/R10 Solar	167
Determining dimensions/order data for combinations	81	Front-mounted roller shutters V10	64

Index

T

Technical information/data	
Solar drive	.65
Test certificate	
Security roller shutter FR23/FR24	.131
Tilting behaviour details	
Front-mounted external venetian blinds R6/R10	.158
Front-mounted external venetian blinds R6/R10 with daylight transport element	.162
Type key/type matrix	.29

W

WAREMA Minitronic dialog	.190
WAREMA Timer and WAREMA Comfort Timer	.191
WAREMA Wisotronic	.193
Wind resistance classes according to DIN EN 13659	.22
WMS – WAREMA Mobile System	.188

List of figures

Fig. 1:	Resistance of thermal transition as a function of the distance (outer edge of window pane – inner edge of roller shutter)	25	Fig. 53:	Crank winder for belt.	88
Fig. 2:	Sound absorbing coefficient as a function of the distance (outer edge of window pane – inner edge of roller shutter)	25	Fig. 54:	Crank winder for cord	88
Fig. 3:	Front-mounted roller shutters V4	36	Fig. 55:	Cord, internal V4/V6	89
Fig. 4:	Box V4	37	Fig. 56:	Cord, internal V10	89
Fig. 5:	Box dimensions V4 rectangular	43	Fig. 57:	Crank, internal – left rolling blind V10	90
Fig. 6:	Box dimensions V4 round	43	Fig. 58:	Crank, internal – right rolling blind V6	91
Fig. 7:	Box dimensions V4 square	44	Fig. 59:	Crank, with pull-out gear	91
Fig. 8:	Box dimensions V4 plaster	44	Fig. 60:	Outlet for motor cable	92
Fig. 9:	Front-mounted roller shutters V6	46	Fig. 61:	Outlet for motor cable when using Minimax guide rail	92
Fig. 10:	Box V6	46	Fig. 62:	Minimax guide rail details	94
Fig. 11:	Box dimensions V6 rectangular	52	Fig. 63:	Security package details	95
Fig. 12:	Box dimensions V6 round	52	Fig. 64:	Mounting procedure	96
Fig. 13:	Box dimensions V6 square	53	Fig. 65:	Mounting substructure	96
Fig. 14:	Box dimensions V6 plaster	53	Fig. 66:	Additional box fastening	97
Fig. 15:	Front-mounted roller shutters V10	56	Fig. 67:	V4/V6: Outlet gap closed	98
Fig. 16:	Box V10	57	Fig. 68:	V10: Outlet gap closed	98
Fig. 15:	Box dimensions V10 rectangular	62	Fig. 69:	Left rolling blind	99
Fig. 16:	Box dimensions V10 round	62	Fig. 70:	Left rolling blind	99
Fig. 17:	Box dimensions V10 square	63	Fig. 71:	Box extension type 5 (shown with belt operation)	100
Fig. 18:	Box dimensions V10 plaster	63	Fig. 72:	Box extension type 5 (shown with belt operation)	101
Fig. 17:	View of the box from underneath	66	Fig. 73:	Box extension type 6	102
Fig. 18:	Detail of solar panel	66	Fig. 74:	Box extension type 7 for combination	102
Fig. 19:	Mounting bracket for solar panel (for external mounting)	66	Fig. 75:	Inner angle, single mitre	103
Fig. 20:	Measuring instructions for individual unit front-mounted roller shutter – installation in the reveal	68	Fig. 76:	Inner angle, polygonal	103
Fig. 21:	Left rolling blind on the reveal	69	Fig. 77:	Inner angle, single mitre	104
Fig. 22:	Left rolling blind in the reveal	69	Fig. 78:	Outer angle, polygonal	104
Fig. 23:	Left rolling blind in the reveal (plaster)	70	Fig. 79:	Outer angle 90°, cut-out in the box	105
Fig. 24:	Right rolling blind in the reveal	70	Fig. 80:	Combination of outside and inner angle	105
Fig. 25:	Left rolling blind in the reveal with projection arm	71	Fig. 81:	Rear cover panel detail for distance guide rails	108
Fig. 26:	Left rolling blind in the reveal with projection arm and insect screen roller blind	71	Fig. 82:	Handle rail for insect screen gauze	119
Fig. 27:	Left rolling blind in the reveal with insect screen roller blind	72	Fig. 83:	Sliding bolt type V7	120
Fig. 28:	Left rolling blind in the reveal with projection arm and insect screen in deep box	73	Fig. 84:	Espagnolette lock	120
Fig. 29:	Left rolling blind in the reveal (plaster)	73	Fig. 85:	Security roller shutter FR 23/FR 24	122
Fig. 30:	Front-mounted roller shutters with integrated insect screen roller blind	74	Fig. 86:	Box	122
Fig. 31:	Position of insect screen handle rail in box and cord tassel detail	75	Fig. 87:	Left rolling blind in the reveal	125
Fig. 32:	Sealing positions of insect screen handle rail	75	Fig. 88:	Left rolling blind on the reveal	125
Fig. 33:	Handle shell for insect screen handle rail	75	Fig. 89:	Crank	126
Fig. 34:	Front-mounted roller shutters with integrated insect screen roller blind	76	Fig. 90:	Motor	126
Fig. 35:	Insect screen swivel frame standard 1 casement available for V4/V6/V10	77	Fig. 91:	FR 23	127
Fig. 36:	Insect screen swivel frame standard 2 casement available for V4/V6/V10	77	Fig. 92:	Push-up guard with adjustable locking squares	127
Fig. 37:	Insect screen swivel frame together with door/window combination available for V4/V6/V10	78	Fig. 93:	FR 24	127
Fig. 38:	Insect screen swivel frame V4/V6/V10 available	78	Fig. 94:	Secured against prying the box out from outside	127
Fig. 39:	Insect screen swivel frame, 1-wing model, for V6/V10 with Minimax guide rails	79	Fig. 95:	Fixing	128
Fig. 40:	Order data	80	Fig. 96:	Guide rail	129
Fig. 41:	External solar panel	80	Fig. 97:	End rail	129
Fig. 42:	Centre rail size 92, 101, 110	81	Fig. 98:	Hooking in of roller shutter curtain and end rail	129
Fig. 43:	Centre rail size 67, 85	81	Fig. 99:	Certificate	130
Fig. 44:	Centre rail size 110	82	Fig. 100:	Test certificate	131
Fig. 45:	Centre rail size 85	82	Fig. 101:	Front-mounted external venetian blinds	134
Fig. 46:	Belt, internal – adjustable belt guiding roller V4/V6	84	Fig. 102:	Box types	134
Fig. 47:	Belt, internal – fixed V4	84	Fig. 103:	Protrusion of the bottom rail	137
Fig. 48:	Belt, internal – right rolling blind V6	85	Fig. 104:	Box sizes	138
Fig. 49:	Belt, internal – adjustable belt guiding roller V10	85	Fig. 105:	Guide rails without insect screen	138
Fig. 50:	Belt – pull-out belt disc	86	Fig. 106:	Aluminium end cap for guide rail (optional)	138
Fig. 51:	Belt deflection type 6a	87	Fig. 107:	Fixing bore holes	138
Fig. 52:	Belt deflection type H	87	Fig. 108:	Position of holes for drilled hole type 2	138
			Fig. 109:	Front-mounted external venetian blinds	140
			Fig. 110:	Box types	140
			Fig. 111:	Protrusion of the bottom rail	144
			Fig. 112:	Box sizes	145
			Fig. 113:	Guide rails without insect screen	145
			Fig. 114:	Guide rails with insect screen	145
			Fig. 115:	Fixing bore holes	146
			Fig. 116:	Aluminium end cap for guide rail (optional)	146
			Fig. 117:	Position of holes for drilled hole type 2	146
			Fig. 118:	Mounting in the reveal	147
			Fig. 119:	Installation in front of the reveal	147
			Fig. 120:	Mounting in the reveal with box embedded in plaster	148
			Fig. 121:	Diagonal cross section of guide rails	148
			Fig. 122:	Presetting of the insect screen	149
			Fig. 123:	Measuring for retrofitting insect screens	149

List of figures

Fig. 124: Front-mounted external venetian blinds with swivel frame, one-wing	150
Fig. 125: Front-mounted external venetian blinds with swivel frame, two-wing	150
Fig. 126: Front-mounted external venetian blinds with swivel frame, two-wing	151
Fig. 127: Order data for 78 mm (100 mm) centre rail (only for R10).	152
Fig. 128: Order data for K centre rail	152
Fig. 129: Box extension type 6	153
Fig. 130: Box extension type 7	153
Fig. 131: Box extension – outlet gap closed (optional)	154
Fig. 132: Plaster square version R6/10 plaster (short plaster square subject to surcharge).	154
Fig. 133: Corner position outer angle	155
Fig. 134: Corner position outer angle – oriel	155
Fig. 135: Corner position inner angle	156
Fig. 136: Corner position inner angle – oriel	156
Fig. 137: Additional box fastening	157
Fig. 138: Operating principle of external venetian blinds with vivamatic®	159
Fig. 139: Mounting example for venetian blinds facade system with vivamatic®	160
Fig. 140: Operating principle of external venetian blinds with slowturn	161
Fig. 141: Model with flat slats	163
Fig. 142:	164
Fig. 143: Measuring instructions for external venetian blind middle motor type D 249	165
Fig. 144: Cable exit	165
Fig. 145: Switching instructions	166
Fig. 146: Mounting bracket for external mounting of solar panel	168
Fig. 147: Solar panel	168
Fig. 148:	169
Fig. 149:	169
Fig. 150: Operating accessories for cord	172
Fig. 151: Operating accessories for crank winder	172
Fig. 152: Operating accessories for belt	173
Fig. 153: Operating accessories for crank	174
Fig. 154: Special joint plate	175
Fig. 155: Order data for crank	175
Fig. 156: Guide rail bracket	176
Fig. 157: Guide rail bracket (2-part/adjustable) – for centre rail size 67/85	176
Fig. 158: Guide rail bracket (2-part/adjustable) – for size 92/110 centre rail	176
Fig. 159: Overview of aluminium roller shutter profiles	180
Fig. 160: Overview of plastic roller shutter profiles	181
Fig. 161: Overview of pressure springs	182
Fig. 162: Vertical belt outlet	183
Fig. 163: Intelligent routing function transfers move commands to distant devices.	188
Fig. 164: Operating principle EWFS	189
Fig. 165: Wiring diagram Minitronic dialog	190
Fig. 166: Wiring diagram WAREMA Timer	191
Fig. 167: Wiring diagram WAREMA climatronic®	192
Fig. 168: Wiring diagram Wisotronic	193

Customer Service Centre

External venetian blinds

Tel. +49 9391 20-3140 • Fax -3149
raffstoren.international@warema.de

Roller shutters

Tel. +49 9391 20-3240 • Fax -3249
rollladen.international@warema.de

Blackout units

Tel. +49 9391 20-3240 • Fax -3249
verdunkelungen.international@warema.de

Awnings

Tel. +49 9391 20-3440, 3340
Fax +49 9391 20-3349
markisen.international@warema.de

Internal sun shading systems

Offers:

Tel. +49 9391 20-3540 • Fax -3549
inside.international@warema.de

Order processing/Application technology:

Tel. +49 3722 710-3540 • Fax -3549
inside.international@warema.de

Control systems

Tel. +49 9391 20-3740 • Fax -3749
steuerungssysteme.international@warema.de



WAREMA Renkhoff SE
Hans-Wilhelm-Renkhoff Straße 2
97828 Marktheidenfeld • Germany
Tel. +49 9391 20-0 • Fax -4299
info@warema.de • www.warema.de

WAREMA International GmbH
Hans-Wilhelm-Renkhoff Straße 2
97828 Marktheidenfeld • Germany
Tel. +49 9391 20-0 • Fax -3899
info@warema.com • www.warema.com

WAREMA Austria GmbH
Zaunweg 6
5071 Wals bei Salzburg • Austria
Tel. +43 662 853015-0 • Fax -99
info@warema.at • www.warema.at

WAREMA France SARL
96, Avenue du Général de Gaulle
92250 La Garenne Colombes • France
Tel. +33 155 6609-40 • Fax -49
info@warema.fr • www.warema.fr

WAREMA Iberia S.L.
C/Juan Ramón Jiménez, 8 - 1a planta
Complejo Eurobuilding
28036 Madrid • Spain
Tel. +34 91 18191-58 • Fax -59
info@warema.es • www.warema.es

WAREMA Schweiz GmbH
Staldenhof 1a
6014 Luzern • Switzerland
Tel. +41 41 25912-20 • Fax -49
info@warema.ch • www.warema.ch

WAREMA Sun Shading (Shanghai) Co., Ltd.
Bldg. 1, No. 123, Jiu Ye Road SQIZ
201700 Shanghai • P.R. China
Tel. +86 21 59869288 • Fax +86 21 59869145
info.china@warema.cn • www.warema.cn

Beijing:
Jianwai SOHO, Room 803 Building 11
39 East 3rd-Ring Road • Chao Yang District
100022 Beijing • P.R. China
Tel. +86 10 58694230 • Fax +86 10 58694223
info@warema.cn • www.warema.cn

Guangzhou:
South Tower of Fuli Yingli Building
1st unit at No. 3, Room 504 • Huaqiang Road
510623 Guangzhou • P.R. China
Tel. +86 20 3803 9940 • Fax +86 20 3803 9942
info@warema.cn • www.warema.cn

Chengdu:
Room 2508, Unit 1 • Building of Shangding International
South of Renmin Road
610000 Chengdu • P.R. China
Tel. +86 28 62336586 • Fax +86 28 62336596
info@warema.cn • www.warema.cn



WAREMA Renkhoff SE · Hans-Wilhelm-Renkhoff-Straße 2 · 97828 Marktheidenfeld · Germany
www.warema.com · info@warema.com

251415en/02.2013 Art. no. 875488