

LOGGIAGLAS

LOGGIAGLAS

LOGGIAGLAS

Sistema scorrevole telescopico studiato per balconi, logge e verande
Telescopic sliding system for balcony, Loggia and terrace / Teleskop Schiebetürsystem für Balkon und Loggiaverglasungen



LOGGIAGLAS LG-500 SET 2 ▶ 134
LOGGIAGLAS LG-500 SET 3 ▶ 136
LOGGIAGLAS LG-500 SET 4 ▶ 138
LOGGIAGLAS LG-500 SET 5 ▶ 140

- Sistema scorrevole telescopico studiato per balconi, logge e verande, ideale per proteggersi da vento e intemperie. Sistema con guida a terra.
- Telescopic sliding system for balcony, Loggia and terrace, ideal for wind and weather protection. System with bottom guide.
- Teleskop Schiebetürsystem für Balkon und Loggiaverglasungen, ideal für Wind-und Wetterschutz. System mit Bodenführung.

LG-500 SET 2

- Sistema 2 ante telescopiche
- System for 2 telescopic doors
- System mit 2 Teleskoptüren

LG-500 SET 3

- Sistema 3 ante telescopiche
- System for 3 telescopic doors
- System mit 3 Teleskoptüren

LG-500 SET 4

- Sistema 4 ante telescopiche
- System for 4 telescopic doors
- System mit 4 Teleskoptüren

LG-500 SET 5

- Sistema 5 ante telescopiche
- System for 5 telescopic doors
- System mit 5 Teleskoptüren

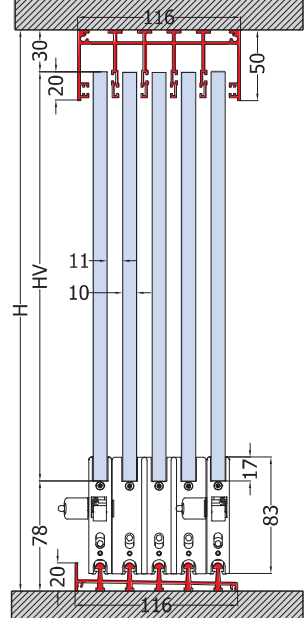
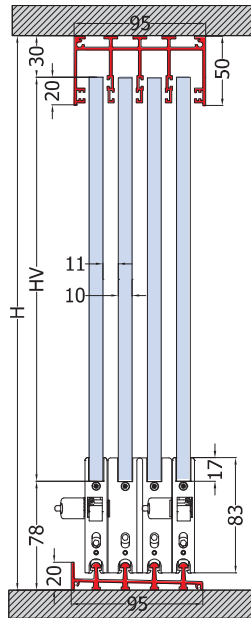
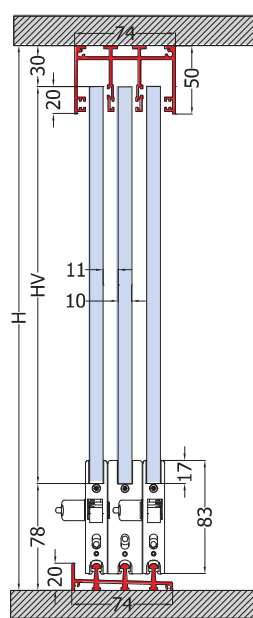
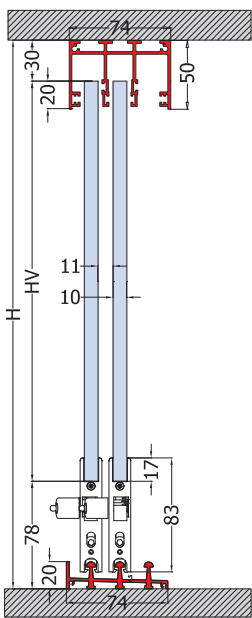

- Possibilità di installare guida a terra incassata nel pavimento
- Ability to install a similar rail embedded in the floor
- Möglichkeit eine Führungsschiene in den Boden einzubauen

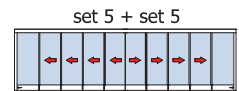
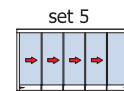
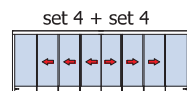
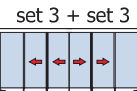
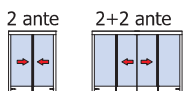
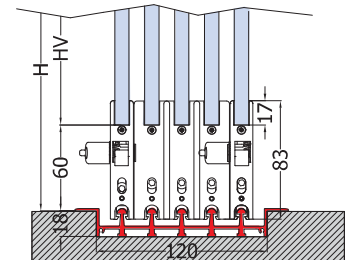
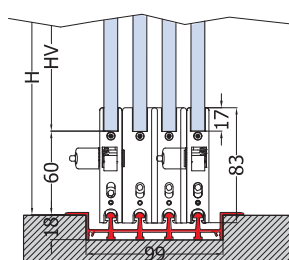
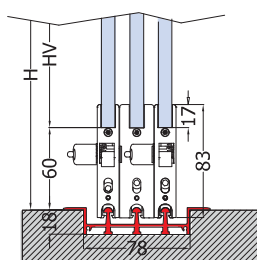
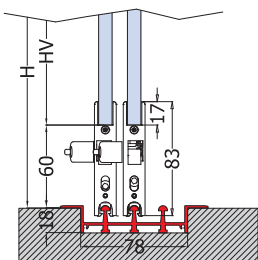

LOGGIAGLAS LG-500 4x4

INNOVAZIONE AL QUADRATO

Il nuovo carrello è un'insieme di innovazione e tecnologia.

Doppia ruota, con cuscinetto a sfera, montata su bilanciere che ne consente l'aderenza contemporanea al binario, rendendo lo scorrimento estremamente fluido.

INNOVATION SQUARED

The new trolley is a blend of innovation and technology. Double wheel, with ball bearing, mounted on a rocker arm that allows its simultaneous adherence to the track, making sliding extremely fluid.

INNOVATION IN QUADRATISCHER FORM

Der neue Wagen ist eine Kombination aus Innovation und Technologie. Zwei Räder mit Kugellager, montiert auf einer Wippe, die das gleichzeitige Aufliegen auf der Schiene garantiert. Dadurch wird die Schiebewegung besonders fließend.

PLUS

PATENT
PENDING



6 Antisollevamento delle ante integrato nel carrello per una sicurezza assoluta ed una semplicità di rimozione, nel caso di manutenzione, grazie al nuovo brevetto Metalglas.

Anti-lifting doors integrated into the trolley for absolute safety and easy removal, in the event of maintenance, thanks to the new Metalglas patent.

Im Wagen ist ein System integriert, das ein Anheben der Türen verhindert. Es sorgt für absolute Sicherheit und garantiert ein einfaches Entfernen für die Wartung.

Dies ist dem neuen Patent von Metalglas zu verdanken.



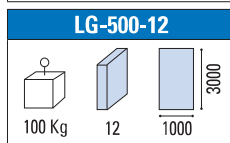
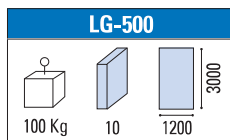

1 Due ruote per carrello vuol dire quattro ruote per anta e quindi spazio alle dimensioni. Libertà di applicazione per poter arrivare fino a 100 Kg di vetro.

Two wheels per trolley means four wheels per door and therefore, it is appropriate for larger sizes. Freedom of application, making it possible to handle up to 100 kg of glass.

Zwei Räder pro Wagen bedeutet vier Räder pro Tür und damit besonders viel Platz. Frei anwendbar für Glas mit einem Gewicht von bis zu 100 kg.

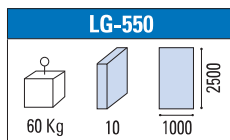

2 ruote per anta
2 wheels each panel
2 Rollen jede Flügel

Possibilità di installare carrelli con un cuscinetto a sfera per ante più leggere.

Ability to install trolleys with a ball bearing for lighter doors.

Möglichkeit des Anbringens von Wägen mit einem Kugellager bei leichteren Türen.



2 Il nuovo carrello favorisce inoltre una facile regolazione in altezza delle ante.

The new trolley also facilitates height adjustment of the doors.

Der neue Wagen ermöglicht außerdem das leichte Einstellen der Höhe der Türen.

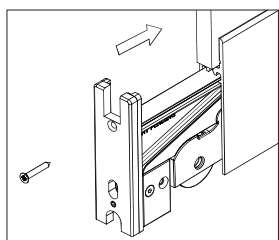

3 Basta tagliare il profilo a misura ed infilare i due carrelli ed il gioco è fatto. Nessuna lavorazione sui profili per questo sistema fantastico ed innovativo.

Just cut the profile to size and slide in the two carts, that's it! No further processing is required on the profiles for this fantastic and innovative system.

Dazu reicht es aus, das Profil nach Maß zuzuschneiden und die zwei Wägen einzufügen. Schon ist die Arbeit erledigt. Keine Arbeit an den Profilen dank dieses fantastischen und innovativen Systems.

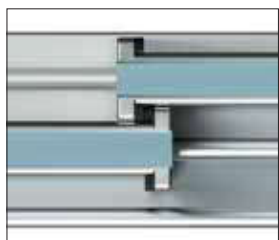

4 Mai più destro o sinistro. Un unico accessorio per tutte le tipologie di apertura.

No longer left or right, a single accessory for all types of openings.

Nie mehr rechts oder links - ein einziges Werkzeug für alle Öffnungsrichtungen.



5 Un altro vantaggio estetico e tecnico è il catenacciolo integrato nel carrello. Semplicità e velocità di applicazione.

Another aesthetic and technical advantage is the espagnolette integrated into the trolley. Simplicity and speed of application.

Ein weiterer ästhetischer und technischer Vorteil besteht im Schließbolzen, der in den Wagen integriert ist. Einfache und schnelle Anwendung.

LOGGIAGLAS LG-500 SET 2

€ ▶ C.322

€ ▶ C.323

SCORREVOLE TELESCOPICO / TELESCOPIC SLIDING SYSTEM / TELESKOP SCHIEBETÜRSYSTEM

• **SISTEMA CON GUIDA A TERRA:**

Sistema scorrevole telescopico studiato per balconi, logge e verande, ideale per proteggersi da vento e intemperie.

• **SYSTEMS WITH BOTTOM GUIDE:**

Telescopic sliding system for balcony, Loggia and terrace, ideal for wind and weather protection.

• **SYSTEM MIT BODENFÜHRUNG:**

Teleskop Schiebetürsystem für Balkon und Loggiaverglasungen, ideal für Wind-und Wetterschutz.



COMPONENTI / COMPONENTS / EINZELTEILE



LG-500			LG-500-12			
100 Kg	10	1200	100 Kg	12	1000	
4 ruote per anta / 4 wheels each panel / 4 Rollen jede Flügel						

LG-550			
60 Kg	10	1000	
2 ruote per anta / 2 wheels each panel / 2 Rollen jede Flügel			

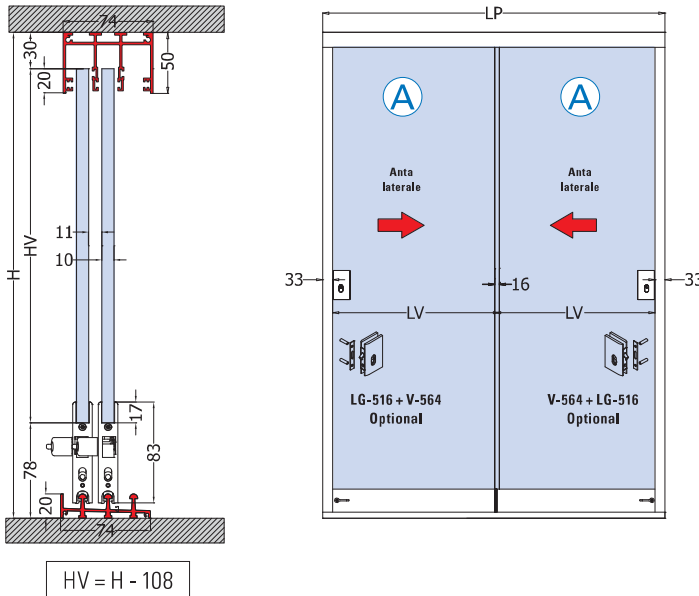
LG-500 / LG-500-12 / LG-550

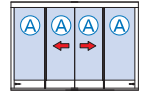
2 ante

2+2 ante

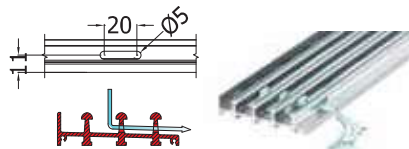
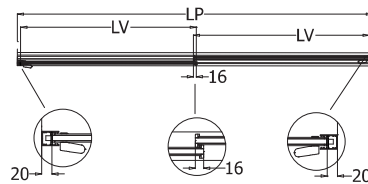
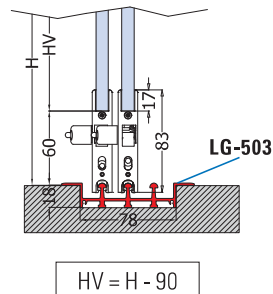
LG-510 / LG-510-12 / LG-560

- Set con guida inferiore incassata
- Set with recessed floor profile
- Set mit versenkter Bodenschiene

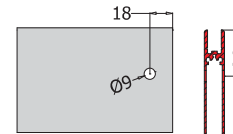

- Asola per scarico acqua a cura del cliente
- Preparation floor profile for drain by customer
- Profilbearbeitung für Abfluss bauseits



- Lavorazione profilo anta per catenacciolo LG-511 / LG-512
- Preparation panel profile for Locking bolt LG-511 / LG-512
- Profilbearbeitung für Feststellriegel LG-511 / LG-512

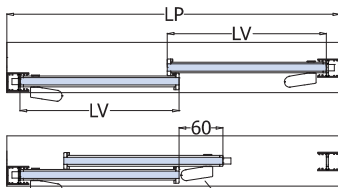
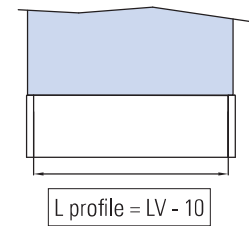

FORMULE CALCOLO VETRI VEDI PAG 142
CALCULATION GLASS SEE PAGE 142
GLASBERECHNUNG SIEHE SEITE 142

LG-500

- **Sistema di autobilanciamento**
 Il nostro carrello a bilanciere autoregola la posizione delle 2 ruote in modo da assicurare lo scorrimento contemporaneo delle ruote sul binario
- **Auto balance mechanism**
 Our seesaw roller system can actively self-adjust the position of the wheels to ensure the wheels are rolling on the rails at the same time
- **Auto balance mechanism**
 Our seesaw roller system can actively self-adjust the position of the wheels to ensure the wheels are rolling on the rails at the same time

xme571b

LP
 Passaggio luce
 Clear opening width
 Lichte Durchgangsbreite

LV
 Larghezza vetro
 Glass width
 Glas Breite

H
 Altezza passaggio luce
 Clear opening height
 Lichte Durchgangshöhe

HV
 Altezza vetro
 Glass height
 Glas Höhe

AN
 Alluminio anodizzato
 Aluminium anodized
 Aluminium Silberfarbig

RAL 9010

LOGGIAGLAS LG-500 SET 3

€ ▶ C.322

€ ▶ C.323

SCORREVOLE TELESCOPICO / TELESCOPIC SLIDING SYSTEM / TELESKOP SCHIEBETÜRSYSTEM

• **SISTEMA CON GUIDA A TERRA:**

Sistema scorrevole telescopico studiato per balconi, logge e verande, ideale per proteggersi da vento e intemperie.

• **SYSTEMS WITH BOTTOM GUIDE:**

Telescopic sliding system for balcony, Loggia and terrace, ideal for wind and weather protection.

• **SYSTEM MIT BODENFÜHRUNG:**

Teleskop Schiebetürsystem für Balkon und Loggiaverglasungen, ideal für Wind-und Wetterschutz.



COMPONENTI / COMPONENTS / EINZELTEILE



LG-501



LG-502



LG-503



LG-505



LG-508



LG-509



LG-510



LG-511



LG-519



LG-520

LG-500			LG-500-12			
100 Kg	10	1200	100 Kg	12	1000	

4 ruote per anta / 4 wheels each panel / 4 Rollen jede Flügel

LG-550			
60 Kg	10	1000	

2 ruote per anta / 2 wheels each panel / 2 Rollen jede Flügel

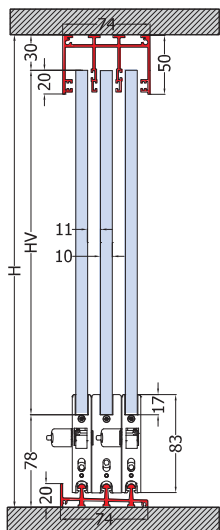
LG-500 / LG-500-12 / LG-550

$$HV = H - 108$$

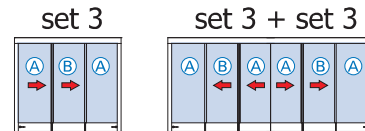
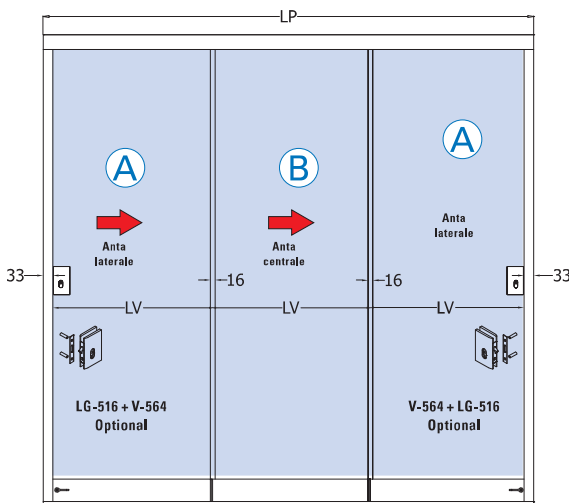
LG-510 / LG-510-12 / LG-560

- Set con guida inferiore incassata
- Set with recessed floor profile
- Set mit versenkter Bodenschiene

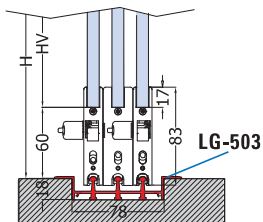

$$HV = H - 90$$

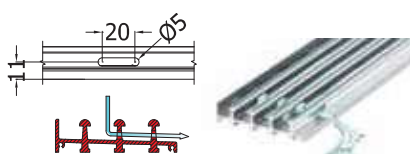
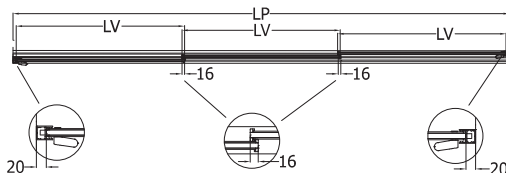

- Asola per scarico acqua a cura del cliente
- Preparation floor profile for drain by customer
- Profilbearbeitung für Abfluss bauseits

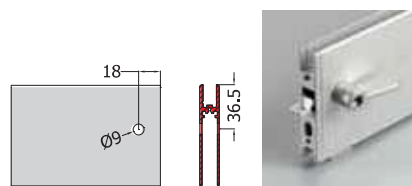

- Lavorazione profilo anta per catenacciolo LG-511 / LG-512.
- Preparation panel profile for Locking bolt LG-511 / LG-512.
- Profilbearbeitung für Feststellriegel LG-511 / LG-512.

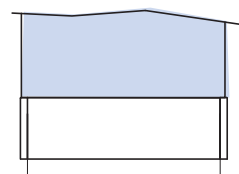

$$L \text{ profile} = LV - 10$$

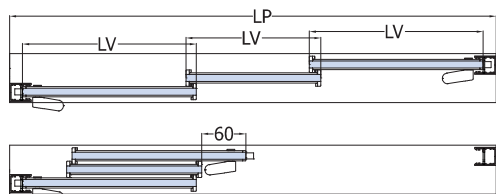
LG-500

- *Sistema di autobilanciamento*
Il nostro carrello a bilanciere autoregola la posizione delle 2 ruote in modo da assicurare lo scorrimento contemporaneo delle ruote sul binario
- *Auto balance mechanism*
Our seesaw roller system can actively self-adjust the position of the wheels to ensure the wheels are rolling on the rails at the same time
- *Auto balance mechanism*
Our seesaw roller system can actively self-adjust the position of the wheels to ensure the wheels are rolling on the rails at the same time

FORMULE CALCOLO VETRI VEDI PAG 143
CALCULATION GLASS SEE PAGE 143
GLASBERECHNUNG SIEHE SEITE 143

xme571c

LP
 Passaggio luce
 Clear opening width
 Lichte Durchgangsbreite

LV
 Larghezza vetro
 Glass width
 Glas Breite

H
 Altezza passaggio luce
 Clear opening height
 Lichte Durchgangshöhe

HV
 Altezza vetro
 Glass height
 Glas Höhe

AN
 Alluminio anodizzato
 Aluminium anodized
 Aluminium Silberfarbig

RAL 9010

LOGGIAGLAS LG-500 SET 4

SCORREVOLE TELESCOPICO / TELESCOPIC SLIDING SYSTEM / TELESKOP SCHIEBETÜRSYSTEM

€ ▶ C.322

€ ▶ C.323

• **SISTEMA CON GUIDA A TERRA:**

Sistema scorrevole telescopico studiato per balconi, logge e verande, ideale per proteggersi da vento e intemperie.

• **SYSTEMS WITH BOTTOM GUIDE:**

Telescopic sliding system for balcony, Loggia and terrace, ideal for wind and weather protection.

• **SYSTEM MIT BODENFÜHRUNG:**

Teleskop Schiebetürsystem für Balkon und Loggiaverglasungen, ideal für Wind-und Wetterschutz.



COMPONENTI / COMPONENTS / EINZELTEILE



LG-504



LG-505



LG-506



LG-507



LG-508



LG-509



LG-510



LG-511



LG-519



LG-520

LG-500			LG-500-12			
100 Kg	10	1200	100 Kg	12	1000	
4 ruote per anta / 4 wheels each panel / 4 Rollen jede Flügel						

LG-550			
60 Kg	10	1000	
2 ruote per anta / 2 wheels each panel / 2 Rollen jede Flügel			

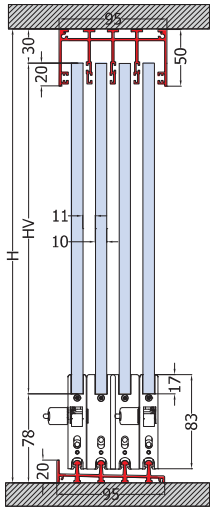
LG-500 / LG-500-12 / LG-550

$$HV = H - 108$$

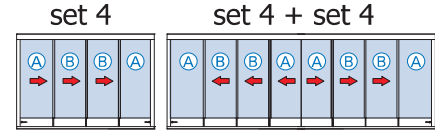
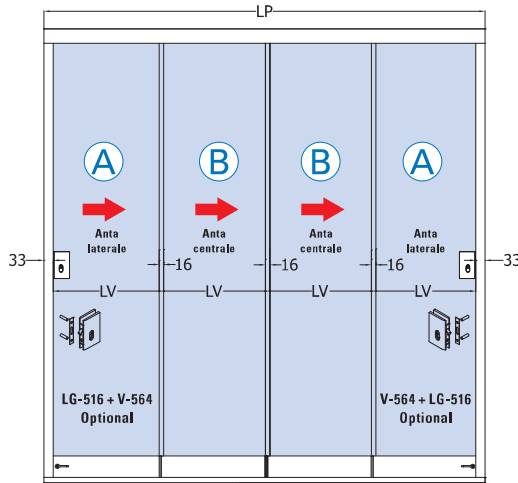
LG-510 / LG-510-12 / LG-560

- Set con guida inferiore incassata
- Set with recessed floor profile
- Set mit versenkter Bodenschiene

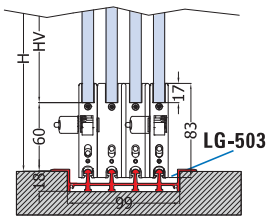

$$HV = H - 90$$

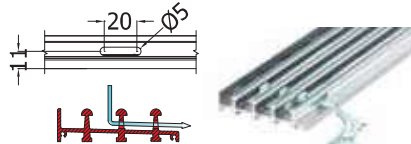
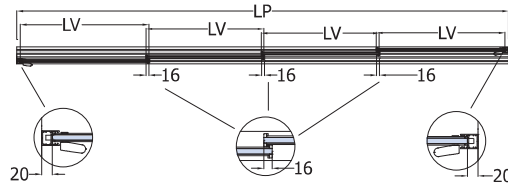

- Asola per scarico acqua a cura del cliente
- Preparation floor profile for drain by customer
- Profilbearbeitung für Abfluss bauseits

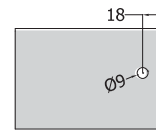

- Lavorazione profilo anta per catenacciolo LG-511 / LG-512.
- Preparation panel profile for Locking bolt LG-511 / LG-512.
- Profilbearbeitung für Feststellriegel LG-511 / LG-512.

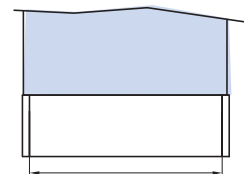

$$L \text{ profile} = LV - 10$$

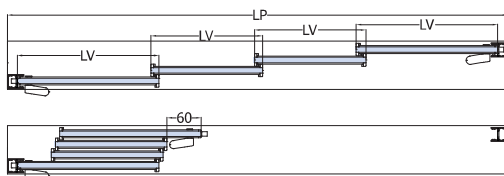
LG-500

- *Sistema di autobilanciamento*
Il nostro carrello a bilanciamento autoregola la posizione delle 2 ruote in modo da assicurare lo scorrimento contemporaneo delle ruote sul binario
- *Auto balance mechanism*
Our seesaw roller system can actively self-adjust the position of the wheels to ensure the wheels are rolling on the rails at the same time
- *Auto balance mechanism*
Our seesaw roller system can actively self-adjust the position of the wheels to ensure the wheels are rolling on the rails at the same time

FORMULE CALCOLO VETRI VEDI PAG 144
CALCULATION GLASS SEE PAGE 144
GLASBERECHNUNG SIEHE SEITE 144

xme571d

LP
 Passaggio luce
 Clear opening width
 Lichte Durchgangsbreite

LV
 Larghezza vetro
 Glass width
 Glas Breite

H
 Altezza passaggio luce
 Clear opening height
 Lichte Durchgangshöhe

HV
 Altezza vetro
 Glass height
 Glas Höhe

AN
 Alluminio anodizzato
 Aluminium anodized
 Aluminium Silberfarbig

RAL 9010

LOGGIAGLAS LG-500 SET 5

€ ▶ C.322

€ ▶ C.323

SCORREVOLE TELESCOPICO / TELESCOPIC SLIDING SYSTEM / TELESKOP SCHIEBETÜRSYSTEM

• **SISTEMA CON GUIDA A TERRA:**

Sistema scorrevole telescopico studiato per balconi, logge e verande, ideale per proteggersi da vento e intemperie.

• **SYSTEMS WITH BOTTOM GUIDE:**

Telescopic sliding system for balcony, Loggia and terrace, ideal for wind and weather protection.

• **SYSTEM MIT BODENFÜHRUNG:**

Teleskop Schiebetürsystem für Balkon und Loggiaverglasungen, ideal für Wind-und Wetterschutz.



COMPONENTI / COMPONENTS / EINZELTEILE



LG-500			LG-500-12			
100 Kg	10	1200	100 Kg	12	1000	

4 ruote per anta / 4 wheels each panel / 4 Rollen jede Flügel

LG-550			
60 Kg	10	1000	

2 ruote per anta / 2 wheels each panel / 2 Rollen jede Flügel

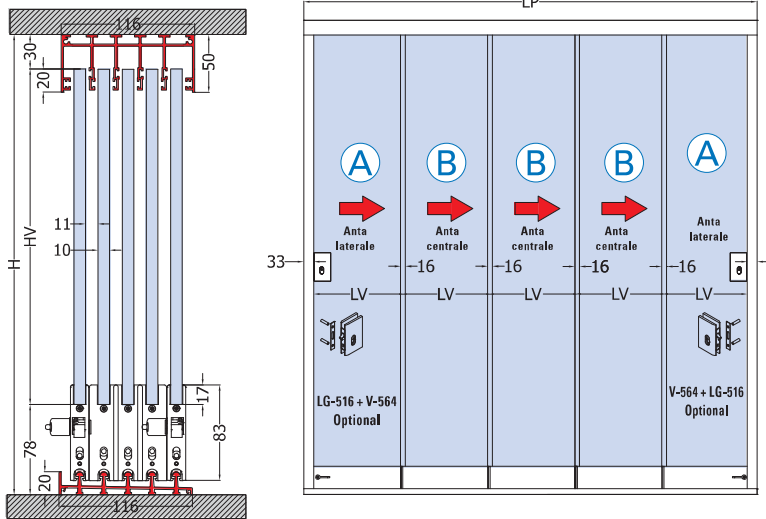
LG-500 / LG-500-12 / LG-550

$$HV = H - 108$$

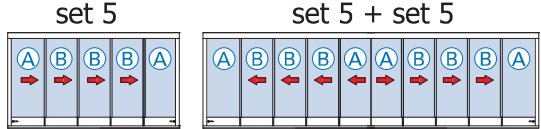
LG-510 / LG-510-12 / LG-560

- Set con guida inferiore incassata
- Set with recessed floor profile
- Set mit versenkter Bodenschiene

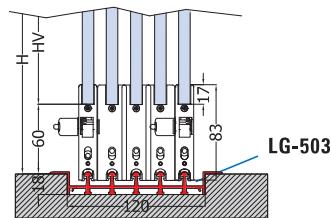

$$HV = H - 90$$

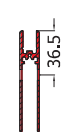
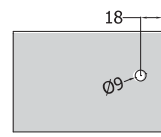
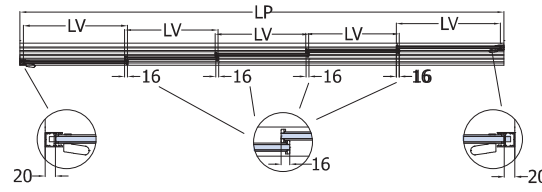

- Lavorazione profilo anta per catenacciolo LG-511 / LG-512.
- Preparation panel profile for Locking bolt LG-511 / LG-512.
- Profilbearbeitung für Feststellriegel LG-511 / LG-512.

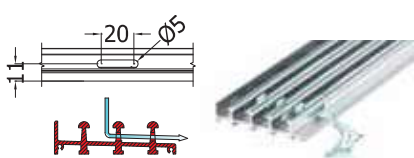

- Asola per scarico acqua a cura del cliente
- Preparation floor profile for drain by customer
- Profilbearbeitung für Abfluss bauseits

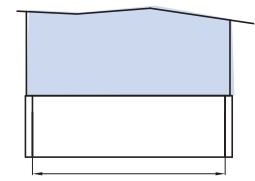

$$L \text{ profile} = LV - 10$$

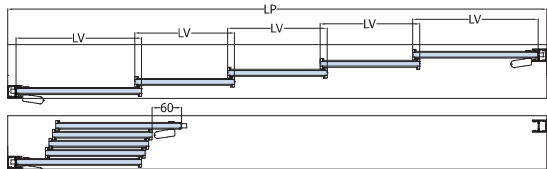
LG-500

- **Sistema di autobilanciamento**
Il nostro carrello a bilanciere autoregola la posizione delle 2 ruote in modo da assicurare lo scorrimento contemporaneo delle ruote sul binario
- **Auto balance mechanism**
Our seesaw roller system can actively self-adjust the position of the wheels to ensure the wheels are rolling on the rails at the same time
- **Auto balance mechanism**
Our seesaw roller system can actively self-adjust the position of the wheels to ensure the wheels are rolling on the rails at the same time

FORMULE CALCOLO VETRI VEDI PAG 145
CALCULATION GLASS SEE PAGE 145
GLASBERECHNUNG SIEHE SEITE 145

LP
Passaggio luce
Clear opening width
Lichte Durchgangsbreite

LV
Larghezza vetro
Glass width
Glas Breite

H
Altezza passaggio luce
Clear opening height
Lichte Durchgangshöhe

HV
Altezza vetro
Glass height
Glas Höhe

AN
Alluminio anodizzato
Aluminium anodized
Aluminium Silberfarbig

RAL 9010

xme571e

LOGGIAGLAS LG-500 SET 2

CALCOLO VETRI / GLASS CALCULATION / GLASBERECHNUNG

C1* = **con** 1 catenacciolo / **with** 1 locking bolt / **mit** 1 Feststellriegel / **C2*** = **con** 2 catenaccioli / **with** 2 locking bolts / **mit** 2 Feststellriegel

LG-500-C1/C2* / LG-500-12-C1/C2* / LG-550-C1/C2*

- Formula calcolo larghezza ante **con** catenaccioli o serrature e **con** montanti laterali LG-508
- Glass calculation **with** locking bolts or locks and **with** "U" side profile LG-508
- Glasberechnung **mit** Feststellriegel oder Schloss und **mit** "U"-seitlichem Profil LG-508

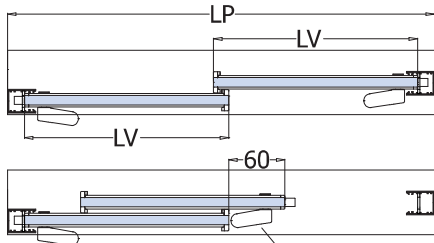

SET 2

$$LV = LP / 2$$

$$LV \text{ Anta Laterale } A = LV - 11$$

SET 2 + SET 2

$$LV = LP / 4$$

$$LV \text{ Anta Laterale } A = LV$$

LG-500 / LG-500-12 / LG-550

- Formula calcolo larghezza ante **senza** catenaccioli o serrature e **senza** montanti laterali LG-508
- Glass calculation **without** locking bolts or locks and **without** "U" side profile LG-508
- Glasberechnung **ohne** Feststellriegel bzw. Schloss und **ohne** "U"-seitliches Profil LG-508

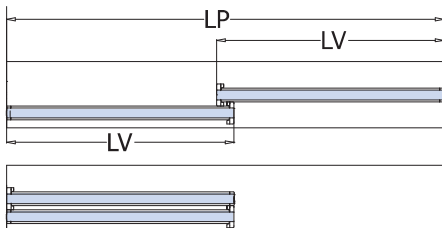

SET 2

$$LV = LP / 2$$

$$LV \text{ Anta Laterale } A = LV + 10$$

SET 2 + SET 2

$$LV = LP / 4$$

$$LV \text{ Anta Laterale } A = LV + 10$$

LG-500 / LG-500-12 / LG-550

- Formula calcolo larghezza ante **senza** catenaccioli e **senza** montanti laterali LG-508, **con** serratura V-564
- Glass calculation **without** locking bolts and **without** "U" side profile LG-508, **with** locks V-564
- Glasberechnung **ohne** Feststellriegel und **ohne** "U"-seitliches Profil LG-508, **mit** Schloss V-564

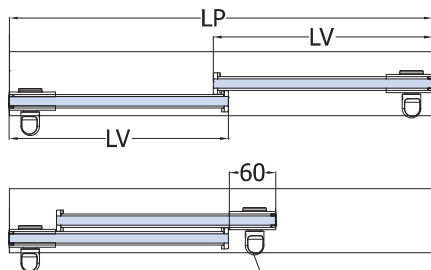

SET 2

$$LV = LP / 2$$

$$LV \text{ Anta Laterale } A = LV + 9$$

SET 2 + SET 2

$$LV = LP / 4$$

$$LV \text{ Anta Laterale } A = LV + 9$$

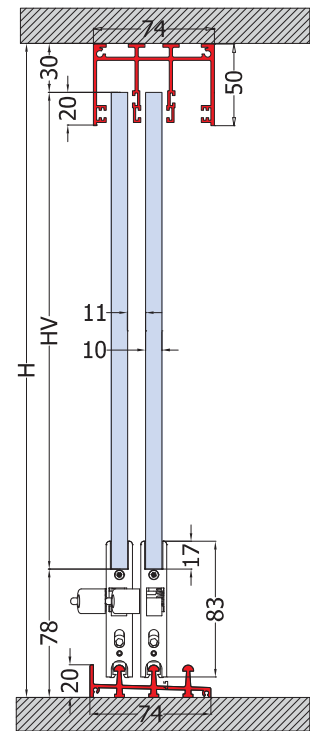

$$HV = H - 108$$

LG-510 / LG-510-12 / LG-560

- Set con guida inferiore incassata
- Set with recessed floor profile
- Set mit versenkter Bodenschiene

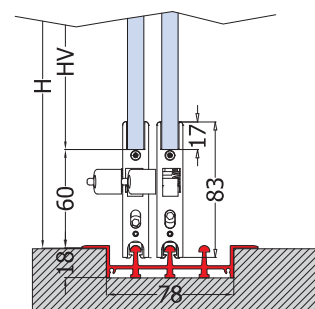

$$HV = H - 90$$

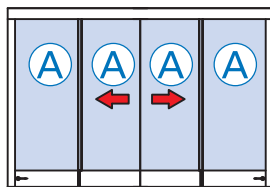
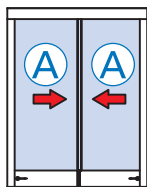

LP
Passaggio luce
Clear opening width
Lichte Durchgangsbreite

LV
Larghezza vetro
Glass width
Glas Breite

H
Altezza passaggio luce
Clear opening height
Lichte Durchgangshöhe

HV
Altezza vetro
Glass height
Glas Höhe

LOGGIAGLAS LG-500 SET 3

CALCOLO VETRI / GLASS CALCULATION / GLASBERECHNUNG

C1* = con 1 catenacciolo / with 1 locking bolt / mit 1 Feststellriegel / **C2*** = con 2 catenaccioli / with 2 locking bolts / mit 2 Feststellriegel

LG-500-C1/C2* / LG-500-12-C1/C2* / LG-550-C1/C2*

- Formula calcolo larghezza ante **con** catenaccioli o serrature e **con** montanti laterali LG-508
- Glass calculation **with** locking bolts or locks and **with** "U" side profile LG-508
- Glasberechnung **mit** Feststellriegel oder Schloss und **mit** "U"-seitlichem Profil LG-508

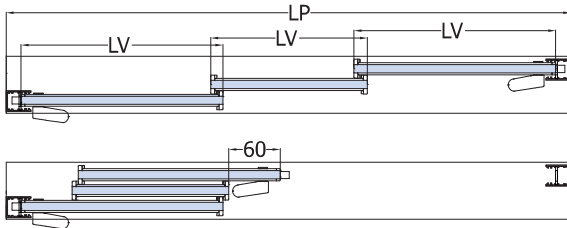

SET 3

LV = LP / 3
 LV Anta Laterale A = LV + 18
 LV Anta Centrale B = LV - 42

SET 3 + SET 3

LV = LP / 6
 LV Anta Laterale A = LV + 25
 LV Anta Centrale B = LV - 35

LG-500 / LG-500-12 / LG-550

- Formula calcolo larghezza ante **senza** catenaccioli o serrature e **senza** montanti laterali LG-508
- Glass calculation **without** locking bolts or locks and **without** "U" side profile LG-508
- Glasberechnung **ohne** Feststellriegel bzw. Schloss und **ohne** "U"-seitliches Profil LG-508

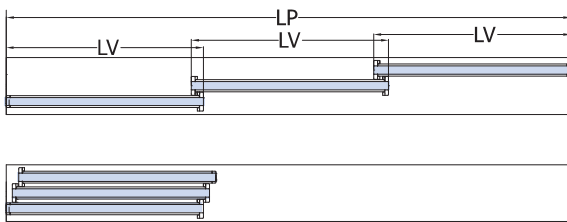

SET 3

LV = LP / 3
 LV Anta Laterale A = LV + 12
 LV Anta Centrale B = LV + 12

SET 3 + SET 3

LV = LP / 6
 LV Anta Laterale A = LV + 12
 LV Anta Centrale B = LV + 12

LG-500 / LG-500-12 / LG-550

- Formula calcolo larghezza ante **senza** catenaccioli e **senza** montanti laterali LG-508, **con** serratura V-564
- Glass calculation **without** locking bolts and **without** "U" side profile LG-508, **with** locks V-564
- Glasberechnung **ohne** Feststellriegel und **ohne** "U"-seitliches Profil LG-508, **mit** Schloss V-564

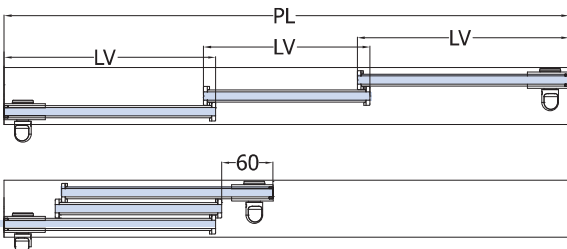

SET 3

LV = LP / 3
 LV Anta Laterale A = LV + 31
 LV Anta Centrale B = LV - 29

SET 3 + SET 3

LV = LP / 6
 LV Anta Laterale A = LV + 31
 LV Anta Centrale B = LV - 29

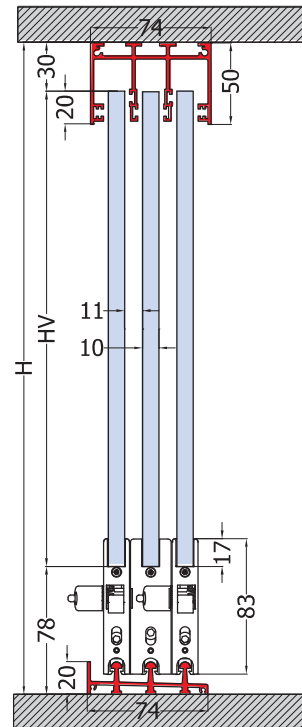

$$HV = H - 108$$

LG-510 / LG-510-12 / LG-560

- Set con guida inferiore incassata
- Set with recessed floor profile
- Set mit versenkter Bodenschiene

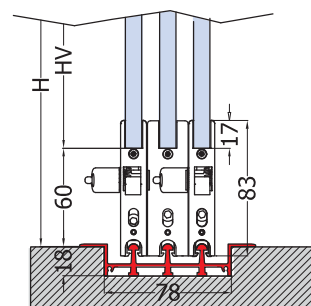

$$HV = H - 90$$

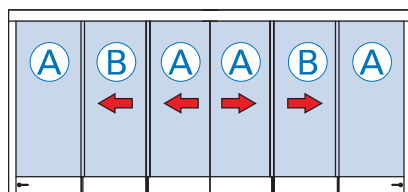
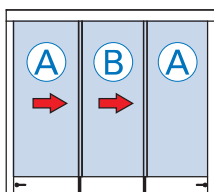

LP
 Passaggio luce
 Clear opening width
 Lichte Durchgangsbreite

LV
 Larghezza vetro
 Glass width
 Glas Breite

H
 Altezza passaggio luce
 Clear opening height
 Lichte Durchgangshöhe

HV
 Altezza vetro
 Glass height
 Glas Höhe

LOGGIAGLAS LG-500 SET 4

CALCOLO VETRI / GLASS CALCULATION / GLASBERECHNUNG

C1* = con 1 catenacciolo / with 1 locking bolt / mit 1 Feststellriegel / C2* = con 2 catenaccioli / with 2 locking bolts / mit 2 Feststellriegel

LG-500-C1/C2* / LG-500-12-C1/C2* / LG-550-C1/C2*

- Formula calcolo larghezza ante con catenaccioli o serrature e con montanti laterali LG-508
- Glass calculation with locking bolts or locks and with "U" side profile LG-508
- Glasberechnung mit Feststellriegel oder Schloss und mit "U"-seitlichem Profil LG-508

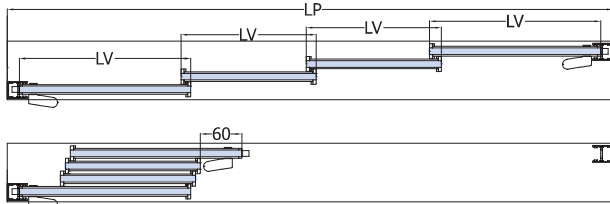

SET 4

$$LV = LP / 4$$

$$LV \text{ Anta Laterale A} = LV + 33$$

$$LV \text{ Anta Centrale B} = LV - 27$$

SET 4 + SET 4

$$LV = LP / 8$$

$$LV \text{ Anta Laterale A} = LV + 38$$

$$LV \text{ Anta Centrale B} = LV - 22$$

LG-500 / LG-500-12 / LG-550

- Formula calcolo larghezza ante senza catenaccioli o serrature e senza montanti laterali LG-508
- Glass calculation without locking bolts or locks and without "U" side profile LG-508
- Glasberechnung ohne Feststellriegel bzw. Schloss und ohne "U"-seitliches Profil LG-508

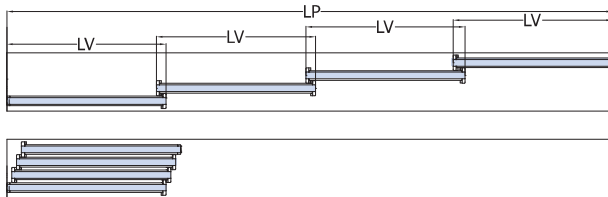

SET 4

$$LV = LP / 4$$

$$LV \text{ Anta Laterale A} = LV + 13$$

$$LV \text{ Anta Centrale B} = LV + 13$$

SET 4 + SET 4

$$LV = LP / 8$$

$$LV \text{ Anta Laterale A} = LV + 13$$

$$LV \text{ Anta Centrale B} = LV + 13$$

LG-500 / LG-500-12 / LG-550

- Formula calcolo larghezza ante senza catenaccioli e senza montanti laterali LG-508, con serratura V-564
- Glass calculation without locking bolts and without "U" side profile LG-508, with locks V-564
- Glasberechnung ohne Feststellriegel und ohne "U"-seitliches Profil LG-508, mit Schloss V-564

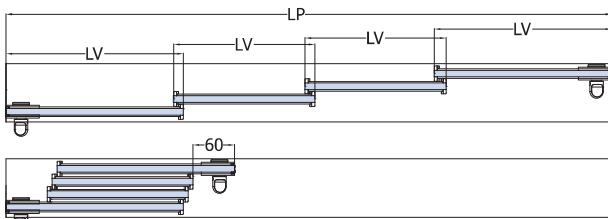

SET 4

$$LV = LP / 4$$

$$LV \text{ Anta Laterale A} = LV + 43$$

$$LV \text{ Anta Centrale B} = LV - 17$$

SET 4 + SET 4

$$LV = LP / 8$$

$$LV \text{ Anta Laterale A} = LV + 43$$

$$LV \text{ Anta Centrale B} = LV - 17$$

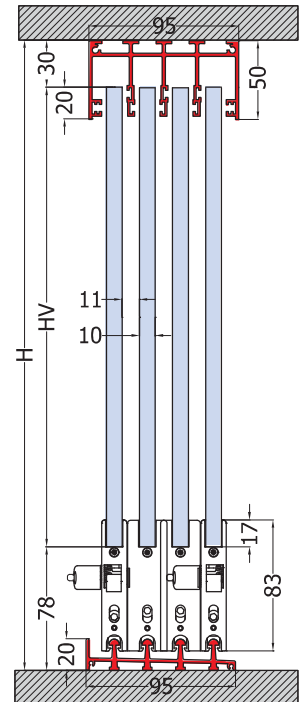

$$HV = H - 108$$

LG-510 / LG-510-12 / LG-560

- Set con guida inferiore incassata
- Set with recessed floor profile
- Set mit versenkter Bodenschiene

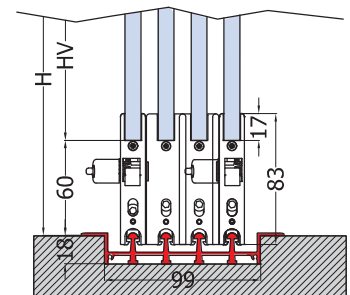

$$HV = H - 90$$

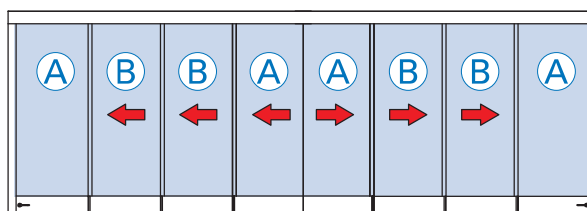
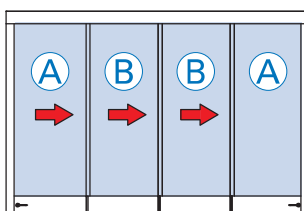

LP
Passaggio luce
Clear opening width
Lichte Durchgangsbreite

LV
Larghezza vetro
Glass width
Glas Breite

H
Altezza passaggio luce
Clear opening height
Lichte Durchgangshöhe

HV
Altezza vetro
Glass height
Glas Höhe

LOGGIAGLAS LG-500 SET 5

CALCOLO VETRI / GLASS CALCULATION / GLASBERECHNUNG

C1* = **con** 1 catenacciolo / **with** 1 locking bolt / **mit** 1 Feststellriegel / C2* = **con** 2 catenaccioli / **with** 2 locking bolts / **mit** 2 Feststellriegel

LG-500-C1/C2* / LG-500-12-C1/C2* / LG-550-C1/C2*

- Formula calcolo larghezza ante **con** catenaccioli o serrature e **con** montanti laterali LG-508
- Glass calculation **with** locking bolts or locks and **with** "U" side profile LG-508
- Glasberechnung **mit** Feststellriegel oder Schloss und **mit** "U"-seitlichem Profil LG-508

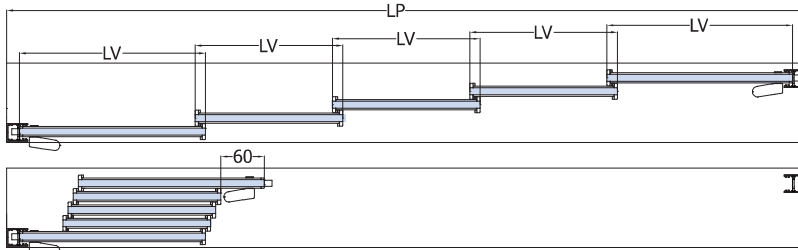

SET 5

LV = LP / 5
 LV Anta Laterale A = LV + 41
 LV Anta Centrale B = LV - 19

SET 5 + SET 5

LV = LP / 10
 LV Anta Laterale A = LV + 45
 LV Anta Centrale B = LV - 15

LG-500 / LG-500-12 / LG-550

- Formula calcolo larghezza ante **senza** catenaccioli o serrature e **senza** montanti laterali LG-508
- Glass calculation **without** locking bolts or locks and **without** "U" side profile LG-508
- Glasberechnung **ohne** Feststellriegel bzw. Schloss und **ohne** "U"-seitliches Profil LG-508

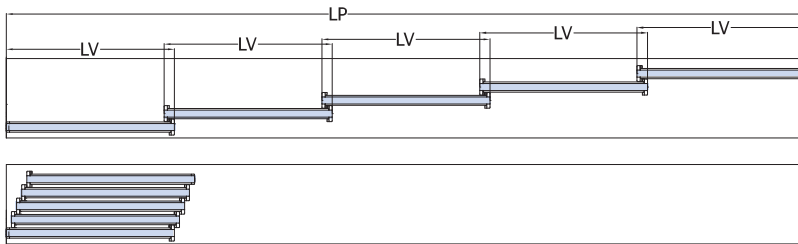

SET 5

LV = LP / 5
 LV Anta Laterale A = LV + 13
 LV Anta Centrale B = LV + 13

SET 5 + SET 5

LV = LP / 10
 LV Anta Laterale A = LV + 13
 LV Anta Centrale B = LV + 13

LG-500 / LG-500-12 / LG-550

- Formula calcolo larghezza ante **senza** catenaccioli e **senza** montanti laterali LG-508, **con** serratura V-564
- Glass calculation **without** locking bolts and **without** "U" side profile LG-508, **with** locks V-564
- Glasberechnung **ohne** Feststellriegel und **ohne** "U"-seitliches Profil LG-508, **mit** Schloss V-564

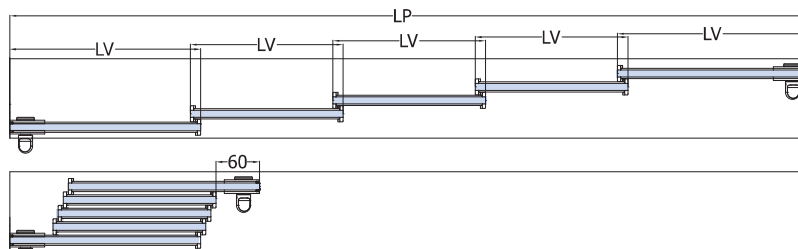

SET 5

LV = LP / 5
 LV Anta Laterale A = LV + 49
 LV Anta Centrale B = LV - 11

SET 5 + SET 5

LV = LP / 10
 LV Anta Laterale A = LV + 49
 LV Anta Centrale B = LV - 11

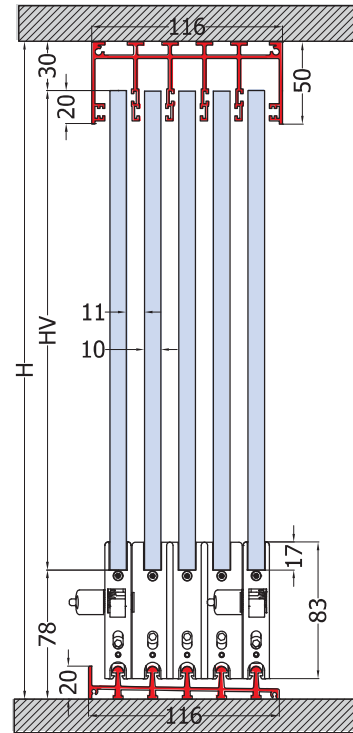

HV = H - 108

LG-510 / LG-510-12 / LG-560

- Set con guida inferiore incassata
- Set with recessed floor profile
- Set mit versenkter Bodenschiene

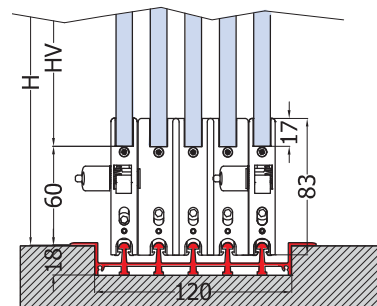

HV = H - 90

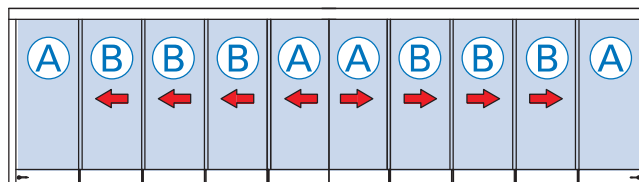
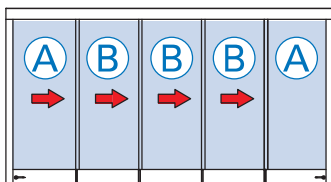

LP
 Passaggio luce
 Clear opening width
 Lichte Durchgangsbreite











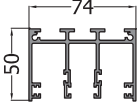

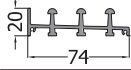

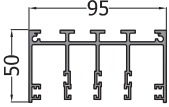

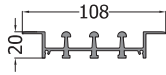

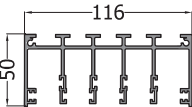

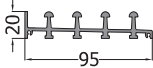
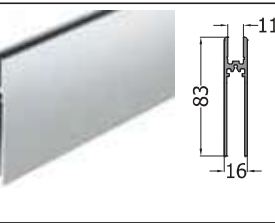

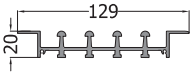
LV
 Larghezza vetro
 Glass width
 Glas Breite

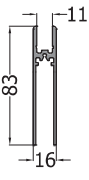
H
 Altezza passaggio luce
 Clear opening height
 Lichte Durchgangshöhe

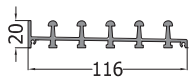
HV
 Altezza vetro
 Glass height
 Glas Höhe

LOGGIAGLAS LG-500 / LG-500-12 / LG-550 / LG-510 / LG-510-12 / LG-560

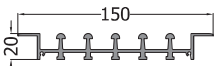

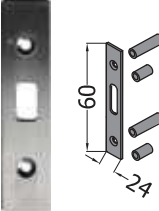
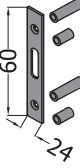
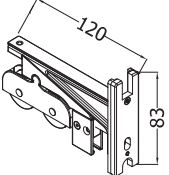
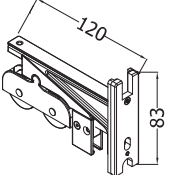
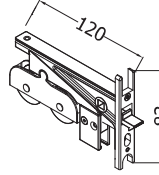
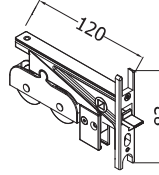

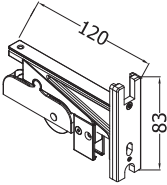
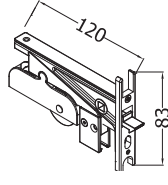
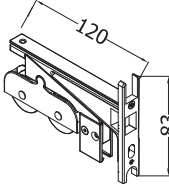
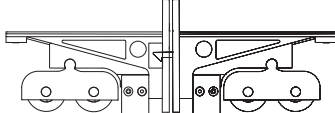
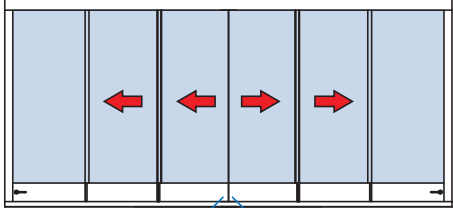
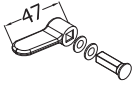
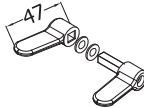
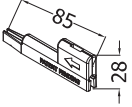
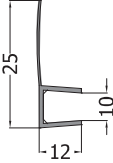

COMPONENTI / COMPONENTS / EINZELTEILE

 <p>LG-501 €▶ C.324</p> <ul style="list-style-type: none"> Binario superiore 3 vie completo di spazzole Track profile 3-ways with brush seals Laufschienenprofil 3-läufig komplett mit Bürstendichtungen 	 <p>LG-502 €▶ C.327</p> <ul style="list-style-type: none"> Guida inferiore 3 vie Floor profile 3-ways Bodenschiene 3-läufig 
 <p>LG-504 €▶ C.325</p> <ul style="list-style-type: none"> Binario superiore 4 vie completo di spazzole Track profile 4-ways with brush seals Laufschienenprofil 4-läufig komplett mit Bürstendichtungen 	 <p>LG-503 €▶ C.328</p> <ul style="list-style-type: none"> Guida inferiore incassata 3 vie Recessed floor profile 3-ways Versenkte Bodenschiene 3-läufig 
 <p>LG-513 €▶ C.326</p> <ul style="list-style-type: none"> Binario superiore 5 vie completo di spazzole Track profile 5-ways with brush seals Laufschienenprofil 5-läufig komplett mit Bürstendichtungen 	 <p>LG-506 €▶ C.329</p> <ul style="list-style-type: none"> Guida inferiore 4 vie Floor profile 4-ways Bodenschiene 4-läufig 
 <p>LG-515 €▶ C.332</p> <ul style="list-style-type: none"> Binario superiore 5 vie completo di spazzole Track profile 5-ways with brush seals Laufschienenprofil 5-läufig komplett mit Bürstendichtungen 	 <p>LG-507 €▶ C.330</p> <ul style="list-style-type: none"> Guida inferiore incassata 4 vie Recessed floor profile 4-ways Versenkte Bodenschiene 4-läufig 
 <p>LG-505 €▶ C.333</p> <ul style="list-style-type: none"> Profilo anta per vetro 10 mm. Foro catenacciolo a carico cliente Horizontal panel profile for glass 10 mm. Hole for locking bolt by customer Horizontal Profil für Türen für Glas 10 mm. Bohrung für Feststeller bauseits 	 <p>LG-514 €▶ C.331</p> <ul style="list-style-type: none"> Guida inferiore 5 vie Floor profile 5-ways Bodenschiene 5-läufig 
 <p>LG-508 €▶ C.335</p> <ul style="list-style-type: none"> Montante laterale ad "U" completo di spazzole "U" side profile with brush seals "U"-seitliches Profil komplett mit Bürstendichtungen 	 <p>LG-515 €▶ C.332</p> <ul style="list-style-type: none"> Guida inferiore incassata 5 vie Recessed floor profile 5-ways Versenkte Bodenschiene 5-läufig 
 <p>LG-505-12 €▶ C.334</p> <ul style="list-style-type: none"> Profilo anta per vetro 12 mm. Foro catenacciolo a carico cliente Horizontal panel profile for glass 12 mm. Hole for locking bolt by customer Horizontal Profil für Türen für Glas 12 mm. Bohrung für Feststeller bauseits 	 <p>LG-516 €▶ C.348</p> <ul style="list-style-type: none"> Contropiastra per serratura V-564 e catenacciolo con montante LG-508 Strike plate for lock V-564 and locking bolt with "U" side profile LG-508 Schließblech für Schloss V-564 und Feststeller mit "U"-seitlichem Profil LG-508 
 <p>LG-509 €▶ C.336</p> <ul style="list-style-type: none"> Carrello con bilanciere a 2 ruote con funzione di trascinamento Seesaw roller with 2 wheels and with dragging function Wippenlaufwagen mit 2 Räder und mit Mitnehmer Funktion 	 <p>LG-510 €▶ C.337</p> <ul style="list-style-type: none"> Catenacciolo / carrello con bilanciere a 2 ruote Locking bolt seesaw roller with 2 wheels Feststeller Wippenlaufwagen mit 2 Räder 

 <p>LG-519 €►C.338</p> <ul style="list-style-type: none"> • Carrello con 1 ruota con funzione di trascinamento • Roller with 1 wheel and with dragging function • Laufwagen mit 1 Rad und mit Mitnehmer Funktion 	 <p>LG-520 €►C.339</p> <ul style="list-style-type: none"> • Catenacciolo / carrello a 1 ruota • Locking bolt roller with 1 wheel • Feststeller Laufwagen mit 1 Rad
<p>LG-521 €►C.340</p> <ul style="list-style-type: none"> • Carrello con bilanciere a 2 ruote e contropiastra per catenacciolo LG-510 con set doppio • Seesaw roller with 2 wheels and strike plate for locking bolt LG-510 with double set • Wippenlaufwagen mit 2 Räder und Schließblech für Feststeller LG-510 mit doppel Set    <p style="text-align: center;">LG-521 LG-510</p> <p style="text-align: center;">LG-521 LG-510</p>	
 <p>LG-511 €►C.341</p> <ul style="list-style-type: none"> • Pomolo singolo per catenacciolo • Single knob for locking bolt • Knopf für Feststeller 	 <p>LG-512 €►C.342</p> <ul style="list-style-type: none"> • Pomolo doppio per catenacciolo • Double knob for locking bolt • Paar Knöpfe für Feststeller
 <p>LG-517 €►C.343</p> <ul style="list-style-type: none"> • Chiave di manutenzione sgancio ante dal sistema antisollevamento • Maintenance tool to release the panels from the anti-lifting mechanism • Revisionswerkzeug um die Türen aus dem Aushebeschutzsystem zu anheben 	 <p>LG-518 €►C.344</p> <ul style="list-style-type: none"> • Guarnizione in PVC trasparente • Seal in transparent PVC • PVC Dichtprofil

ACCESSORI / ACCESSORIES / ZUBEHÖRE

<p>V-564 €►C.345</p> <ul style="list-style-type: none"> • Serratura Minima 55 con gancio per scorrevole. Cilindro e contropiastra non inclusi • Lock Minima 55 with hook for sliding doors. Cylinder and strike plate not included • Minima 55 Schloss mit Hakenriegel für Schiebetüren. Zylinder und Schließblech nicht enthalten <p>CP - NS</p>	<p>V-569 2FLG €►C.346</p> <ul style="list-style-type: none"> • Controserratura • Strike box • Gegenkasten <p>CP - NS</p>	<p>V-564-LG €►C.347</p> <ul style="list-style-type: none"> • Serratura Minima 55 con gancio per scorrevole, copertine un lato con foro cilindro e un lato cieco • Lock Minima 55 with hook, covers with one side blind and one side with oval cylinder hole • Minima 55 Schloss mit Hakenriegel für Schiebetüren. Abdeckungen mit einer Seite blind und einer Seite Zylinder vorgerichtet <p>CP - NS</p>
		 <p>LATO CILINDRO CYLINDER SIDE</p> <p>LATO CIECO BLIND SIDE</p> <p>LAVORAZIONE VETRO GLASS PREPARATION GLASBEARBEITUNG</p> 

<p>C-010 €►C.349</p> <ul style="list-style-type: none"> • Cilindro simmetrico ovale • Oval cylinder symmetrical • Ovaler Zylinder symmetrisch 	<p>C-011 €►C.350</p> <ul style="list-style-type: none"> • Cilindro W.C. ovale • Oval W.C. cylinder • Ovaler WC Zylinder 	<p>C-012 €►C.351</p> <ul style="list-style-type: none"> • Cilindro ovale chiave/pomolo • Oval cylinder knob/key • Ovaler Zylinder Knopf/Schlüssel 	<p>C-015 €►C.352</p> <ul style="list-style-type: none"> • Mezzo cilindro • Half-cylinder • Halb-Zylinder 	<p>V-524 €►C.353</p> <ul style="list-style-type: none"> • Paio nicchie per scorrevole tonde, Ø 60 • Pair sliding door-handles, Ø 60 • Paar Griffmuscheln, Ø 60 <p>AN - NS</p>  
--	---	---	---	---